



# AMBA<sup>®</sup> AXI Protocol Specification

Document number	ARM IHI 0022
Document quality	EAC
Document version	Issue K
Document confidentiality	Non-confidential
Date of issue	September 2023

*Copyright © 2003-2023 Arm Limited or its affiliates. All rights reserved.*

# AMBA® AXI Protocol Specification

## Release information

Date	Version	Changes
2023/Sep/29	K	<ul style="list-style-type: none"><li>• EAC-0 release of Issue K.</li><li>• Memory Encryption Contexts (MEC).</li><li>• Memory System Resource Partitioning and Monitoring (MPAM) extension.</li><li>• Memory Tagging Extension (MTE) Simplified option.</li><li>• Other minor additions, corrections, and clarifications.</li></ul>
2023/Mar/01	J	<ul style="list-style-type: none"><li>• EAC-0 release of Issue J.</li><li>• Simplified document structure.</li><li>• AXI3, AXI4, AXI4-Lite, ACE, and ACE5 content removed.</li><li>• New content added for AXI5, AXI5-Lite, ACE5-Lite, ACE5-LiteDVM, and ACE5-LiteACP interface classes.</li></ul>
2021/Jan/26	H.c	<ul style="list-style-type: none"><li>• Corrected error in table D13-22 for AxADDR[15].</li></ul>
2021/Jan/11	H.b	<ul style="list-style-type: none"><li>• Regularized terminology to use Manager to indicate the agent that initiates read and write requests and Subordinate to indicate the agent that responds to read and write requests.</li></ul>
2020/Mar/31	H	<ul style="list-style-type: none"><li>• EAC-0 release of Issue H.</li><li>• New optional features defined for AMBA 5 interface variants.</li></ul>
2019/Jul/30	G	<ul style="list-style-type: none"><li>• EAC-0 release of Issue G.</li><li>• New optional features defined for AMBA 5 interface variants.</li></ul>
2017/Dec/21	F.b	<ul style="list-style-type: none"><li>• EAC-1 release to address issues found with the EAC-0 release of release F.</li></ul>
2017/Dec/18	F	<ul style="list-style-type: none"><li>• EAC-0 release of Issue F.</li><li>• New interfaces defined for AMBA protocol: AXI5, AXI5-Lite, ACE5, ACE5-Lite, ACE5-LiteDVM, and ACE5-LiteACP.</li></ul>
2013/Feb/22	E	<ul style="list-style-type: none"><li>• Second release of AMBA AXI and ACE Protocol specification.</li></ul>
2011/Oct/28	D	<ul style="list-style-type: none"><li>• First release of AMBA AXI and ACE Protocol specification.</li></ul>
2011/Jun/03	D-2c	<ul style="list-style-type: none"><li>• Public beta draft of AMBA AXI and ACE Protocol specification.</li></ul>
2010/Mar/03	C	<ul style="list-style-type: none"><li>• First release of AXI specification v2.0.</li></ul>
2004/Mar/19	B	<ul style="list-style-type: none"><li>• First release of AXI specification v1.0.</li></ul>
2003/Jun/16	A	<ul style="list-style-type: none"><li>• First release.</li></ul>

## Proprietary Notice

This document is **NON-CONFIDENTIAL** and any use by you is subject to the terms of this notice and the Arm AMBA Specification Licence set about below.

This document is protected by copyright and other related rights and the practice or implementation of the information contained in this document may be protected by one or more patents or pending patent applications. No part of this document may be reproduced in any form by any means without the express prior written permission of Arm. **No license, express or implied, by estoppel or otherwise to any intellectual property rights is granted by this document unless specifically stated.**

Your access to the information in this document is conditional upon your acceptance that you will not use or permit others to use the information for the purposes of determining whether implementations infringe any third party patents.

THIS DOCUMENT IS PROVIDED “AS IS”. ARM PROVIDES NO REPRESENTATIONS AND NO WARRANTIES, EXPRESS, IMPLIED OR STATUTORY, INCLUDING, WITHOUT LIMITATION, THE IMPLIED WARRANTIES OF MERCHANTABILITY, SATISFACTORY QUALITY, NON-INFRINGEMENT OR FITNESS FOR A PARTICULAR PURPOSE WITH RESPECT TO THE DOCUMENT. For the avoidance of doubt, Arm makes no representation with respect to, and has undertaken no analysis to identify or understand the scope and content of, patents, copyrights, trade secrets, or other rights.

This document may include technical inaccuracies or typographical errors.

TO THE EXTENT NOT PROHIBITED BY LAW, IN NO EVENT WILL ARM BE LIABLE FOR ANY DAMAGES, INCLUDING WITHOUT LIMITATION ANY DIRECT, INDIRECT, SPECIAL, INCIDENTAL, PUNITIVE, OR CONSEQUENTIAL DAMAGES, HOWEVER CAUSED AND REGARDLESS OF THE THEORY OF LIABILITY, ARISING OUT OF ANY USE OF THIS DOCUMENT, EVEN IF ARM HAS BEEN ADVISED OF THE POSSIBILITY OF SUCH DAMAGES.

This document consists solely of commercial items. You shall be responsible for ensuring that any use, duplication or disclosure of this document complies fully with any relevant export laws and regulations to assure that this document or any portion thereof is not exported, directly or indirectly, in violation of such export laws. Use of the word “partner” in reference to Arm’s customers is not intended to create or refer to any partnership relationship with any other company. Arm may make changes to this document at any time and without notice.

This document may be translated into other languages for convenience, and you agree that if there is any conflict between the English version of this document and any translation, the terms of the English version of the Agreement shall prevail.

The Arm corporate logo and words marked with ® or ™ are registered trademarks or trademarks of Arm Limited (or its subsidiaries) in the US and/or elsewhere. All rights reserved. Other brands and names mentioned in this document may be the trademarks of their respective owners. Please follow Arm’s trademark usage guidelines at <http://www.arm.com/company/policies/trademarks>

Copyright © 2003-2023 Arm Limited (or its affiliates). All rights reserved.

Arm Limited. Company 02557590 registered in England.

110 Fulbourn Road, Cambridge, England CB1 9NJ.

LES-PRE-21451 version 2.2

## AMBA SPECIFICATION LICENCE

THIS END USER LICENCE AGREEMENT (“LICENCE”) IS A LEGAL AGREEMENT BETWEEN YOU (EITHER A SINGLE INDIVIDUAL, OR SINGLE LEGAL ENTITY) AND ARM LIMITED (“ARM”) FOR THE USE OF ARM’S INTELLECTUAL PROPERTY (INCLUDING, WITHOUT LIMITATION, ANY COPYRIGHT) IN THE RELEVANT AMBA SPECIFICATION ACCOMPANYING THIS LICENCE. ARM LICENSES THE RELEVANT AMBA SPECIFICATION TO YOU ON CONDITION THAT YOU ACCEPT ALL OF THE TERMS IN THIS LICENCE. BY CLICKING “I AGREE” OR OTHERWISE USING OR COPYING THE RELEVANT AMBA SPECIFICATION YOU INDICATE THAT YOU AGREE TO BE BOUND BY ALL THE TERMS OF THIS LICENCE.

“LICENSEE” means You and your Subsidiaries. “Subsidiary” means, if You are a single entity, any company the majority of whose voting shares is now or hereafter owned or controlled, directly or indirectly, by You. A company shall be a Subsidiary only for the period during which such control exists.

1. Subject to the provisions of Clauses 2, 3 and 4, Arm hereby grants to LICENSEE a perpetual, non-exclusive, non-transferable, royalty free, worldwide licence to:
  - (i) use and copy the relevant AMBA Specification for the purpose of developing and having developed products that comply with the relevant AMBA Specification;
  - (ii) manufacture and have manufactured products which either: (a) have been created by or for LICENSEE under the licence granted in Clause 1(i); or (b) incorporate a product(s) which has been created by a third party(s) under a licence granted by Arm in Clause 1(i) of such third party’s AMBA Specification Licence; and
  - (iii) offer to sell, sell, supply or otherwise distribute products which have either been (a) created by or for LICENSEE under the licence granted in Clause 1(i); or (b) manufactured by or for LICENSEE under the licence granted in Clause 1(ii).
2. LICENSEE hereby agrees that the licence granted in Clause 1 is subject to the following restrictions:
  - (i) where a product created under Clause 1(i) is an integrated circuit which includes a CPU then either: (a) such CPU shall only be manufactured under licence from Arm; or (b) such CPU is neither substantially compliant with nor marketed as being compliant with the Arm instruction sets licensed by Arm from time to time;
  - (ii) the licences granted in Clause 1(iii) shall not extend to any portion or function of a product that is not itself compliant with part of the relevant AMBA Specification; and
  - (iii) no right is granted to LICENSEE to sublicense the rights granted to LICENSEE under this Agreement.
3. Except as specifically licensed in accordance with Clause 1, LICENSEE acquires no right, title or interest in any Arm technology or any intellectual property embodied therein. In no event shall the licences granted in accordance with Clause 1 be construed as granting LICENSEE, expressly or by implication, estoppel or otherwise, a licence to use any Arm technology except the relevant AMBA Specification.
4. THE RELEVANT AMBA SPECIFICATION IS PROVIDED “AS IS” WITH NO REPRESENTATION OR WARRANTIES EXPRESS, IMPLIED OR STATUTORY, INCLUDING BUT NOT LIMITED TO ANY WARRANTY OF SATISFACTORY QUALITY, MERCHANTABILITY, NON-INFRINGEMENT OR FITNESS FOR A PARTICULAR PURPOSE, OR THAT ANY USE OR IMPLEMENTATION OF SUCH ARM TECHNOLOGY WILL NOT INFRINGE ANY THIRD PARTY PATENTS, COPYRIGHTS, TRADE SECRETS OR OTHER INTELLECTUAL PROPERTY RIGHTS.
5. NOTWITHSTANDING ANYTHING TO THE CONTRARY CONTAINED IN THIS AGREEMENT, TO THE FULLEST EXTENT PERMITTED BY LAW, THE MAXIMUM LIABILITY OF ARM IN AGGREGATE FOR ALL CLAIMS MADE AGAINST ARM, IN CONTRACT, TORT OR OTHERWISE, IN CONNECTION WITH THE SUBJECT MATTER OF THIS AGREEMENT (INCLUDING WITHOUT LIMITATION (I) LICENSEE’S USE OF THE ARM TECHNOLOGY; AND (II) THE IMPLEMENTATION OF THE ARM TECHNOLOGY IN ANY PRODUCT CREATED BY LICENSEE UNDER THIS AGREEMENT) SHALL NOT EXCEED THE FEES PAID (IF ANY) BY LICENSEE TO ARM UNDER THIS AGREEMENT. THE EXISTENCE OF MORE THAN ONE CLAIM OR SUIT WILL NOT ENLARGE OR EXTEND THE LIMIT. LICENSEE RELEASES ARM FROM ALL OBLIGATIONS, LIABILITY, CLAIMS OR DEMANDS IN EXCESS OF THIS LIMITATION.

6. No licence, express, implied or otherwise, is granted to LICENSEE, under the provisions of Clause 1, to use the Arm tradename, or AMBA trademark in connection with the relevant AMBA Specification or any products based thereon. Nothing in Clause 1 shall be construed as authority for LICENSEE to make any representations on behalf of Arm in respect of the relevant AMBA Specification.
7. This Licence shall remain in force until terminated by you or by Arm. Without prejudice to any of its other rights if LICENSEE is in breach of any of the terms and conditions of this Licence then Arm may terminate this Licence immediately upon giving written notice to You. You may terminate this Licence at any time. Upon expiry or termination of this Licence by You or by Arm LICENSEE shall stop using the relevant AMBA Specification and destroy all copies of the relevant AMBA Specification in your possession together with all documentation and related materials. Upon expiry or termination of this Licence, the provisions of clauses 6 and 7 shall survive.
8. The validity, construction and performance of this Agreement shall be governed by English Law.

## **Confidentiality Status**

This document is Non-Confidential. The right to use, copy and disclose this document may be subject to license restrictions in accordance with the terms of the agreement entered into by Arm and the party that Arm delivered this document to.

## **Product Status**

The information in this document is final, that is for a developed product.

## **Web Address**

<http://www.arm.com>

## **Inclusive language commitment**

Arm values inclusive communities. Arm recognizes that we and our industry have used terms that can be offensive.

Arm strives to lead the industry and create change.

Previous issues of this document included terms that can be offensive. We have replaced these terms. If you find offensive terms in this document, please contact [terms@arm.com](mailto:terms@arm.com).

# Contents

## AMBA® AXI Protocol Specification

AMBA® AXI Protocol Specification . . . . .	ii
Release information . . . . .	ii
Proprietary Notice . . . . .	iii
AMBA SPECIFICATION LICENCE . . . . .	iv
Confidentiality Status . . . . .	v
Product Status . . . . .	v
Web Address . . . . .	v
Inclusive language commitment . . . . .	v

### Preface

Intended audience . . . . .	xiii
Using this specification . . . . .	xiii
Conventions . . . . .	xv
Typographical conventions . . . . .	xv
Timing diagrams . . . . .	xv
Signals . . . . .	xvi
Numbers . . . . .	xvi
Pseudocode descriptions . . . . .	xvi
Additional reading . . . . .	xvii
Feedback . . . . .	xviii
Feedback on this specification . . . . .	xviii

## Part A Specification

### Chapter A1

#### Introduction

A1.1	About the AXI protocol . . . . .	21
A1.2	AXI Architecture . . . . .	22
A1.2.1	Channel definition . . . . .	23
A1.2.2	Interface and interconnect . . . . .	24
A1.2.3	Register slices . . . . .	25
A1.3	Terminology . . . . .	26
A1.3.1	AXI components and topology . . . . .	26
A1.3.2	AXI transactions and transfers . . . . .	26
A1.3.3	Caches and cache operation . . . . .	26
A1.3.4	Temporal description . . . . .	26

### Chapter A2

#### Signal list

A2.1	Write channels . . . . .	28
A2.1.1	Write request channel . . . . .	28
A2.1.2	Write data channel . . . . .	29
A2.1.3	Write response channel . . . . .	30
A2.2	Read channels . . . . .	31
A2.2.1	Read request channel . . . . .	31
A2.2.2	Read data channel . . . . .	32
A2.3	Snoop channels . . . . .	33
A2.3.1	Snoop request channel . . . . .	33
A2.3.2	Snoop response channel . . . . .	33
A2.4	Interface level signals . . . . .	34

	A2.4.1	Clock and reset signals . . . . .	34
	A2.4.2	Wakeup signals . . . . .	34
	A2.4.3	QoS Accept signals . . . . .	34
	A2.4.4	Coherency Connection signals . . . . .	35
	A2.4.5	Interface control signals . . . . .	35
<b>Chapter A3</b>	<b>AXI Transport</b>		
	A3.1	Clock and reset . . . . .	37
	A3.1.1	Clock . . . . .	37
	A3.1.2	Reset . . . . .	37
	A3.2	Channel handshake . . . . .	38
	A3.3	Write and read channels . . . . .	40
	A3.3.1	Write request channel (AW) . . . . .	40
	A3.3.2	Write data channel (W) . . . . .	40
	A3.3.3	Write response channel (B) . . . . .	41
	A3.3.4	Read request channel (AR) . . . . .	41
	A3.3.5	Read data channel (R) . . . . .	42
	A3.4	Relationships between the channels . . . . .	43
	A3.5	Dependencies between channel handshake signals . . . . .	44
	A3.5.1	Write transaction dependencies . . . . .	44
	A3.5.2	Read transaction dependencies . . . . .	44
	A3.6	Snoop channels . . . . .	46
	A3.6.1	Snoop request channel (AC) . . . . .	46
	A3.6.2	Snoop response channel (CR) . . . . .	46
	A3.6.3	Snoop transaction dependencies . . . . .	47
<b>Chapter A4</b>	<b>AXI Transactions</b>		
	A4.1	Transaction request . . . . .	49
	A4.1.1	Size attribute . . . . .	49
	A4.1.2	Length attribute . . . . .	50
	A4.1.3	Maximum number of bytes in a transaction . . . . .	51
	A4.1.4	Burst attribute . . . . .	51
	A4.1.5	Transfer address . . . . .	54
	A4.1.6	Transaction equations . . . . .	54
	A4.1.7	Pseudocode description of the transfers . . . . .	56
	A4.1.8	Regular transactions . . . . .	57
	A4.2	Write and read data . . . . .	58
	A4.2.1	Write strobes . . . . .	58
	A4.2.2	Narrow transfers . . . . .	58
	A4.2.3	Byte invariance . . . . .	59
	A4.2.4	Unaligned transfers . . . . .	61
	A4.3	Transaction response . . . . .	65
	A4.3.1	Write response . . . . .	65
	A4.3.2	Read response . . . . .	66
	A4.3.3	Subordinate Busy indicator . . . . .	68
<b>Chapter A5</b>	<b>Request attributes</b>		
	A5.1	Subordinate types . . . . .	71
	A5.2	Memory Attributes . . . . .	72
	A5.2.1	Bufferable, AxCACHE[0] . . . . .	72
	A5.2.2	Modifiable, AxCACHE[1] . . . . .	73
	A5.2.3	Allocate and Other Allocate, AxCACHE[2], and AxCACHE[3] . . . . .	74
	A5.3	Memory types . . . . .	75
	A5.3.1	Memory type requirements . . . . .	75
	A5.3.2	Mismatched memory attributes . . . . .	78

A5.3.3	Changing memory attributes . . . . .	78
A5.3.4	Transaction buffering . . . . .	78
A5.3.5	Example use of Device memory types . . . . .	79
A5.4	Protocol errors . . . . .	81
A5.4.1	Software protocol error . . . . .	81
A5.4.2	Hardware protocol error . . . . .	81
A5.5	Memory protection and the Realm Management Extension . . . . .	82
A5.6	Memory Encryption Contexts . . . . .	84
A5.6.1	MEC signaling . . . . .	84
A5.6.2	MECID usage . . . . .	85
A5.7	Multiple region interfaces . . . . .	87
A5.7.1	Region identifier signaling . . . . .	87
A5.7.2	Using the region identifier . . . . .	87
A5.8	QoS signaling . . . . .	89
A5.8.1	QoS identifiers . . . . .	89
A5.8.2	QoS acceptance indicators . . . . .	90

## Chapter A6

### Transaction identifiers and ordering

A6.1	Transaction identifiers . . . . .	93
A6.1.1	Transaction ID signals . . . . .	93
A6.2	Unique ID indicator . . . . .	94
A6.3	Request ordering . . . . .	96
A6.3.1	Memory locations and Peripheral regions . . . . .	96
A6.3.2	Device and Normal requests . . . . .	97
A6.3.3	Observation and completion definitions . . . . .	97
A6.3.4	Manager ordering guarantees . . . . .	97
A6.3.5	Subordinate ordering requirements . . . . .	98
A6.3.6	Interconnect ordering requirements . . . . .	99
A6.3.7	Response before the endpoint . . . . .	99
A6.3.8	Ordering between requests with different memory types . . . . .	100
A6.3.9	Ordered write observation . . . . .	101
A6.4	Interconnect use of transaction identifiers . . . . .	102
A6.5	Write data and response ordering . . . . .	103
A6.6	Read data ordering . . . . .	104
A6.6.1	Read data interleaving . . . . .	104
A6.6.2	Read data chunking . . . . .	105

## Chapter A7

### Atomic accesses

A7.1	Single-copy atomicity size . . . . .	111
A7.2	Multi-copy write atomicity . . . . .	112
A7.3	Exclusive accesses . . . . .	113
A7.3.1	Exclusive access sequence . . . . .	113
A7.3.2	Exclusive access from the perspective of the Manager . . . . .	114
A7.3.3	Exclusive access restrictions . . . . .	114
A7.3.4	Exclusive access from the perspective of the Subordinate . . . . .	115
A7.4	Atomic transactions . . . . .	116
A7.4.1	Overview . . . . .	116
A7.4.2	Atomic transaction operations . . . . .	117
A7.4.3	Atomic transactions attributes . . . . .	117
A7.4.4	ID use for Atomic transactions . . . . .	119
A7.4.5	Request attribute restrictions for Atomic transactions . . . . .	119
A7.4.6	Atomic transaction signaling . . . . .	120
A7.4.7	Transaction structure . . . . .	121
A7.4.8	Response signaling . . . . .	122
A7.4.9	Atomic transaction dependencies . . . . .	122



	A7.4.10	Support for Atomic transactions . . . . .	123
<b>Chapter A8</b>		<b>Request Opcodes</b>	
	A8.1	Opcode signaling . . . . .	126
	A8.2	AWSNOOP encodings . . . . .	128
	A8.3	ARSNOOP encodings . . . . .	131
<b>Chapter A9</b>		<b>Caches</b>	
	A9.1	Caching in AXI . . . . .	134
	A9.2	Cache line size . . . . .	135
	A9.3	Cache coherency and Domains . . . . .	137
	A9.3.1	System Domain . . . . .	137
	A9.3.2	Non-shareable Domain . . . . .	137
	A9.3.3	Shareable Domain . . . . .	137
	A9.3.4	Domain signaling . . . . .	138
	A9.3.5	Domain consistency . . . . .	139
	A9.3.6	Domains and memory types . . . . .	139
	A9.4	I/O coherency . . . . .	140
	A9.5	Caching Shareable lines . . . . .	141
	A9.5.1	Opcodes to support reading and writing full cache lines . . . . .	142
	A9.5.2	Configuration of Shareable cache support . . . . .	143
	A9.6	Prefetch transaction . . . . .	145
	A9.6.1	Rules for the prefetch transaction . . . . .	145
	A9.6.2	Response for prefetched data . . . . .	146
	A9.7	Cache Stashing . . . . .	147
	A9.7.1	Stash transaction Opcodes . . . . .	147
	A9.7.2	Stash transaction signaling . . . . .	148
	A9.7.3	Stash request Domain . . . . .	148
	A9.7.4	Stash target identifiers . . . . .	149
	A9.7.5	Transaction ID for stash transactions . . . . .	150
	A9.7.6	Support for stash transactions . . . . .	151
	A9.8	Deallocating read transactions . . . . .	152
	A9.8.1	Deallocating read Opcodes . . . . .	152
	A9.8.2	Rules and recommendations . . . . .	152
	A9.9	Invalidate hint . . . . .	154
	A9.9.1	Invalidate Hint signaling . . . . .	154
	A9.9.2	Invalidate Hint support . . . . .	155
<b>Chapter A10</b>		<b>Cache maintenance</b>	
	A10.1	Cache Maintenance Operations . . . . .	157
	A10.2	Actions on receiving a CMO . . . . .	158
	A10.3	CMO request attributes . . . . .	159
	A10.4	CMO propagation . . . . .	160
	A10.5	CMOs on the write channels . . . . .	161
	A10.6	Write with CMO . . . . .	163
	A10.6.1	Attributes for write with CMO . . . . .	164
	A10.6.2	Propagation of write with CMO . . . . .	164
	A10.6.3	Response to write with CMOs . . . . .	164
	A10.6.4	Example flow with a write plus CMO . . . . .	165
	A10.7	CMOs on the read channels . . . . .	166
	A10.8	CMOs for Persistence . . . . .	167
	A10.8.1	Point of Persistence and Deep Persistence . . . . .	167
	A10.8.2	Persistent CMO (PCMO) transactions . . . . .	167
	A10.8.3	PCMO propagation . . . . .	168
	A10.8.4	PCMOs on write channels . . . . .	168

A10.8.5	PCMOs on read channels . . . . .	170
A10.9	Cache Maintenance and Realm Management Extension . . . . .	171
A10.9.1	CMO to PoPA . . . . .	171
A10.9.2	CMO to PoPA propagation . . . . .	172
A10.10	Processor cache maintenance instructions . . . . .	173
A10.10.1	Unpredictable behavior with software cache maintenance . . . . .	173

**Chapter A11**

**Additional request qualifiers**

A11.1	Non-secure Access Identifiers (NSAID) . . . . .	176
A11.1.1	NSAID signaling . . . . .	176
A11.1.2	Caching and NSAID . . . . .	177
A11.2	Page-based Hardware Attributes (PBHA) . . . . .	178
A11.2.1	PBHA values . . . . .	178
A11.3	Subsystem Identifier . . . . .	179
A11.3.1	Subsystem ID usage . . . . .	179

**Chapter A12**

**Other write transactions**

A12.1	WriteZero Transaction . . . . .	181
A12.2	WriteDeferrable Transaction . . . . .	182
A12.2.1	WriteDeferrable transaction support . . . . .	182
A12.2.2	WriteDeferrable signaling . . . . .	182
A12.2.3	Response to a WriteDeferrable request . . . . .	183

**Chapter A13**

**System monitoring, debug, and user extensions**

A13.1	Memory System Resource Partitioning and Monitoring (MPAM) . . . . .	185
A13.1.1	MPAM signaling . . . . .	185
A13.1.2	MPAM fields . . . . .	186
A13.1.3	MPAM component interactions . . . . .	187
A13.2	Memory Tagging Extension (MTE) . . . . .	188
A13.2.1	MTE support . . . . .	188
A13.2.2	MTE signaling . . . . .	189
A13.2.3	Caching tags . . . . .	189
A13.2.4	Transporting tags . . . . .	190
A13.2.5	Reads with tags . . . . .	191
A13.2.6	Writes with tags . . . . .	192
A13.2.7	Memory tagging interoperability . . . . .	195
A13.2.8	MTE and Atomic transactions . . . . .	195
A13.2.9	MTE and Prefetch transactions . . . . .	196
A13.2.10	MTE and Poison . . . . .	196
A13.3	Trace signals . . . . .	197
A13.4	User Loopback signaling . . . . .	198
A13.5	User defined signaling . . . . .	200
A13.5.1	Configuration . . . . .	200
A13.5.2	User signals . . . . .	200
A13.5.3	Usage considerations . . . . .	201

**Chapter A14**

**Untranslated Transactions**

A14.1	Introduction to Distributed Virtual Memory . . . . .	203
A14.2	Support for untranslated transactions . . . . .	204
A14.3	Untranslated transaction signaling . . . . .	205
A14.4	Translation identifiers . . . . .	206
A14.4.1	Secure Stream Identifier (SECSID) . . . . .	206
A14.4.2	StreamID (SID) . . . . .	207
A14.4.3	SubstreamID (SSID) . . . . .	207
A14.4.4	PCIe considerations . . . . .	207

A14.5	Translation fault flows . . . . .	208
A14.5.1	Stall flow . . . . .	209
A14.5.2	ATST flow . . . . .	209
A14.5.3	NoStall flow . . . . .	209
A14.5.4	PRI flow . . . . .	210
A14.6	Untranslated transaction qualifier . . . . .	211
A14.7	StashTranslation Opcode . . . . .	212
A14.8	UnstashTranslation Opcode . . . . .	213

## Chapter A15

### Distributed Virtual Memory messages

A15.1	Introduction to DVM transactions . . . . .	215
A15.2	Support for DVM messages . . . . .	216
A15.3	DVM messages . . . . .	217
A15.3.1	DVM message fields . . . . .	217
A15.3.2	TLB Invalidate messages . . . . .	222
A15.3.3	Branch Predictor Invalidate messages . . . . .	226
A15.3.4	Instruction cache invalidations . . . . .	227
A15.3.5	Synchronization message . . . . .	229
A15.3.6	Hint message . . . . .	229
A15.4	Transporting DVM messages . . . . .	230
A15.4.1	Signaling for DVM messages . . . . .	230
A15.4.2	Address widths in DVM messages . . . . .	232
A15.4.3	Mapping message fields to signals . . . . .	232
A15.5	DVM Sync and Complete . . . . .	239
A15.6	Coherency Connection signaling . . . . .	241
A15.6.1	Coherency Connection Handshake . . . . .	241

## Chapter A16

### Wake-up signaling

A16.1	About Wake-up signals . . . . .	245
A16.2	AWAKEUP rules and recommendations . . . . .	246
A16.2.1	AWAKEUP and Coherency Connection signaling . . . . .	246
A16.3	ACWAKEUP rules and recommendations . . . . .	247

## Chapter A17

### Interface and data protection

A17.1	Data protection using Poison . . . . .	249
A17.2	Parity protection for data and interface signals . . . . .	250
A17.2.1	Configuration of parity protection . . . . .	250
A17.2.2	Error detection behavior . . . . .	251
A17.2.3	Parity check signals . . . . .	251

## Part B Appendices

### Chapter B1

#### Interface classes

B1.1	Summary of interface classes . . . . .	258
B1.1.1	AXI5 . . . . .	259
B1.1.2	ACE5-Lite . . . . .	259
B1.1.3	ACE5-LiteDVM . . . . .	259
B1.1.4	ACE5-LiteACP . . . . .	260
B1.1.5	AXI5-Lite . . . . .	260
B1.2	Signal matrix . . . . .	261
B1.3	Parity check signal matrix . . . . .	266
B1.4	Property matrix . . . . .	269

### Chapter B2

#### Summary of ID constraints

Contents  
Contents

**Chapter B3**

**Revisions**

B3.1	Differences between Issue H.c and Issue J . . . . .	274
B3.2	Differences between Issue J and Issue K . . . . .	276

**Part C Glossary**

**Chapter C1**

**Glossary**

# Preface

This preface describes the content organization and documentation conventions used in this specification.

## Intended audience

This specification is written for hardware and software engineers who want to become familiar with the AMBA protocol and design systems and modules that are compatible with the AXI protocol.

## Using this specification

The information in this specification is organized into parts, as described in this section:

### **Part A Specification**

#### *Chapter A1 Introduction*

Introduces the AXI protocol architecture and terminology used in this specification.

#### *Chapter A2 Signal list*

A list of all the signals that are defined in the AXI protocol.

#### *Chapter A3 AXI Transport*

Provides information on the basic operations of the AXI protocol, such as read and write transactions, channel signaling requirements, and relationships between channels.

#### *Chapter A4 AXI Transactions*

Contains information on the AXI protocol transactions, such as transaction request, transaction response, and read and write data.

#### *Chapter A5 Request attributes*

Describes memory attributes, memory types, memory protection, and multiple region interfaces.

#### *Chapter A6 Transaction identifiers and ordering*

Describes transaction ID signals, request ordering, write data and response ordering, and read data ordering.

#### *Chapter A7 Atomic accesses*

Contains information on Atomic accesses, single and multi-copy atomicity, and exclusive accesses.

#### *Chapter A8 Request Opcodes*

Provides information on the opcode field that describes the function of a request and indicates how it must be processed by a Subordinate.

#### *Chapter A9 Caches*

Describes caching in the AXI protocol, including I/O coherency, caching shareable lines, and managing cache allocation using specific transactions.

#### *Chapter A10 Cache maintenance*

Provides information on using cache maintenance operations to control cache content ensuring visibility of data.

[Chapter A11 Additional request qualifiers](#)

Describes additional request qualifiers in the AXI protocol, such as Non-secure Access Identifier (NSAID), Page-based Hardware Attributes (PBHA), and Subsystem Identifier.

[Chapter A12 Other write transactions](#)

Contains information on other write transactions in the AXI protocol, such as WriteDeferrable and WriteZero.

[Chapter A13 System monitoring, debug, and user extensions](#)

Describes system debug, trace, and monitoring features of the AXI protocol, such as Memory System Resource Partitioning and Monitoring (MPAM), Memory Tagging Extension (MTE), and User Loopback and User defined signaling.

[Chapter A14 Untranslated Transactions](#)

Describes how AXI supports the use of virtual addresses and translation stash hints for components upstream of a System Memory Management Unit (SMMU).

[Chapter A15 Distributed Virtual Memory messages](#)

Describes how AXI supports distributed system MMUs using Distributed Virtual Memory (DVM) messages to maintain all MMUs in a virtual memory system.

[Chapter A16 Wake-up signaling](#)

Describes wake-up signals which can be used for interface clock or power control.

[Chapter A17 Interface and data protection](#)

Explains how to protect data or interfaces using poison and parity check signals.

**Part B Appendices**

[Chapter B1 Interface classes](#)

Descriptions of all the AMBA 5 AXI interface classes, including signal and property tables.

[Chapter B2 Summary of ID constraints](#)

A summary of ID constraints in the AXI protocol.

[Chapter B3 Revisions](#)

Details of the changes between this issue and the previous issue of this specification.

**Part C Glossary**

[Chapter C1 Glossary](#)

Learn about the AXI protocol terms and concepts.

# Conventions

## Typographical conventions

The typographical conventions are:

*italic*

Highlights important notes, introduces special terminology, and denotes internal cross-references and citations.

**bold**

Denotes signal names, and is used for terms in descriptive lists, where appropriate.

monospace

Used for assembler syntax descriptions, pseudocode, and source code examples.

Also used in the main text for instruction mnemonics and for references to other items appearing in assembler syntax descriptions, pseudocode, and source code examples.

SMALL CAPITALS

Used in body text for a few terms that have specific technical meanings.

Colored text

Indicates a link. This can be:

- A cross-reference that includes the page number of the referenced information if it is not on the current page.
- A URL, for example <http://developer.arm.com>.
- A link, to a chapter or appendix, or to a glossary entry, or to the section of the document that defines the colored term.

## Timing diagrams

The components used in timing diagrams are explained in [Figure 1](#). Variations have clear labels when they occur. Do not assume any timing information that is not explicit in the diagrams.

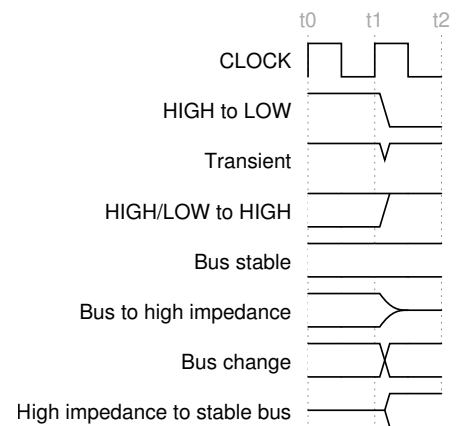

**Figure 1: Key to timing diagram conventions**

Timing diagrams sometimes show single-bit signals as HIGH and LOW at the same time and they look similar to the bus change shown in [Figure 1](#). If a timing diagram shows a single-bit signal in this way, then its value does not affect the accompanying description.

## Signals

The signal conventions are:

- **Signal level** - The level of an asserted signal depends on whether the signal is active-HIGH or active-LOW. Asserted means:
  - HIGH for active-HIGH signals.
  - LOW for active-LOW signals.
- **Lowercase n** - At the start or end of a signal name denotes an active-LOW signal.
- **Lowercase x** - At the second letter of a signal name denotes a collective term for both Read and Write. For example, **AxCACHE** refers to both the **ARCACHE** and **AWCACHE** signals.

## Numbers

Numbers are normally written in decimal. Binary numbers are preceded by `0b`, and hexadecimal numbers by `0x`. In both cases, the prefix and the associated value are written in a monospace font, for example `0xFFFF0000`. To improve readability, long numbers can be written with an underscore separator between every four characters, for example `0xFFFF_0000_0000_0000`. Ignore any underscores when interpreting the value of a number.

## Pseudocode descriptions

This specification uses a form of pseudocode to provide precise descriptions of the specified functionality. This pseudocode is written in a monospace font. The pseudocode language is described in the *Arm® Architecture Reference Manual for A-profile architecture*.



## Additional reading

This section lists publications by Arm and by third parties.

See Arm Developer, <http://developer.arm.com> for access to Arm documentation.

[1] *AMBA® AXI and ACE Protocol Specification*. (ARM IHI 0022 H.c).

[2] *AMBA® AXI Protocol Specification*. (ARM IHI 0022 J).

[3] *Arm® Architecture Reference Manual for A-profile architecture*. (ARM DDI 0487).

[4] *Arm® Realm Management Extension (RME) System Architecture*. (ARM DEN 0129).

[5] *AMBA® 5 CHI Architecture Specification*. (ARM IHI 0050).

[6] *Arm® Architecture Reference Manual Supplement, Memory System Resource Partitioning and Monitoring (MPAM), for A-profile architecture*. (ARM DDI 0598).

[7] *Arm® System Memory Management Unit Architecture Specification, SMMU architecture version 3*. (ARM IHI 0070).

# Feedback

Arm welcomes feedback on its documentation.

## Feedback on this specification

If you have any comments or suggestions for additions and improvements, create a ticket at <https://support.developer.arm.com>. As part of the ticket, please include:

- The title (AMBA® AXI Protocol Specification).
- The number (ARM IHI 0022 Issue K).
- The page numbers to which your comments apply.
- A concise explanation of your comments.

Arm also welcomes general suggestions for additions and improvements.

---

### Note

Arm tests PDFs only in Adobe Acrobat and Acrobat Reader, and cannot guarantee the appearance or behavior of any document when viewed with any other PDF reader.

---

# Part A Specification

# Chapter A1

## Introduction

This chapter introduces the architecture of the AXI protocol and the terminology used in this specification.

It contains the following sections:

- [A1.1 About the AXI protocol](#)
- [A1.2 AXI Architecture](#)
- [A1.3 Terminology](#)

## A1.1 About the AXI protocol

The AXI protocol supports high-performance, high-frequency system designs for communication between Manager and Subordinate components.

The AXI protocol features are:

- Suitable for high-bandwidth and low-latency designs.
- High-frequency operation is provided without using complex bridges.
- The protocol meets the interface requirements of a wide range of components.
- Suitable for memory controllers with high initial access latency.
- Flexibility in the implementation of interconnect architectures is provided.
- Backward-compatible with AHB and APB interfaces.

The key features of the AXI protocol are:

- Separate address/control and data phases.
- Support for unaligned data transfers using byte strobes.
- Uses burst-based transactions with only the start address issued.
- Separate write and read data channels that can provide low-cost Direct Memory Access (DMA).
- Support for issuing multiple outstanding addresses.
- Support for out-of-order transaction completion.
- Permits easy addition of register stages to provide timing closure.

For the previous issues of this specification, see [1] and [2].

## A1.2 AXI Architecture

The AXI protocol is transactions-based and defines five independent channels:

- Write request, which has signal names beginning with **AW**.
- Write data, which has signal names beginning with **W**.
- Write response, which has signal names beginning with **B**.
- Read request, which has signal names beginning with **AR**.
- Read data, which has signal names beginning with **R**.

A request channel carries control information that describes the nature of the data to be transferred. This is known as a request.

The data is transferred between Manager and Subordinate using either:

- A write data channel to transfer data from the Manager to the Subordinate. In a write transaction, the Subordinate uses the write response channel to signal the completion of the transfer to the Manager.
- A read data channel to transfer data from the Subordinate to the Manager.

The AXI protocol:

- Permits address information to be issued ahead of the actual data transfer.
- Supports multiple outstanding transactions.
- Supports out-of-order completion of transactions.

Figure A1.1 shows how a write transaction uses the write request, write data, and write response channels.

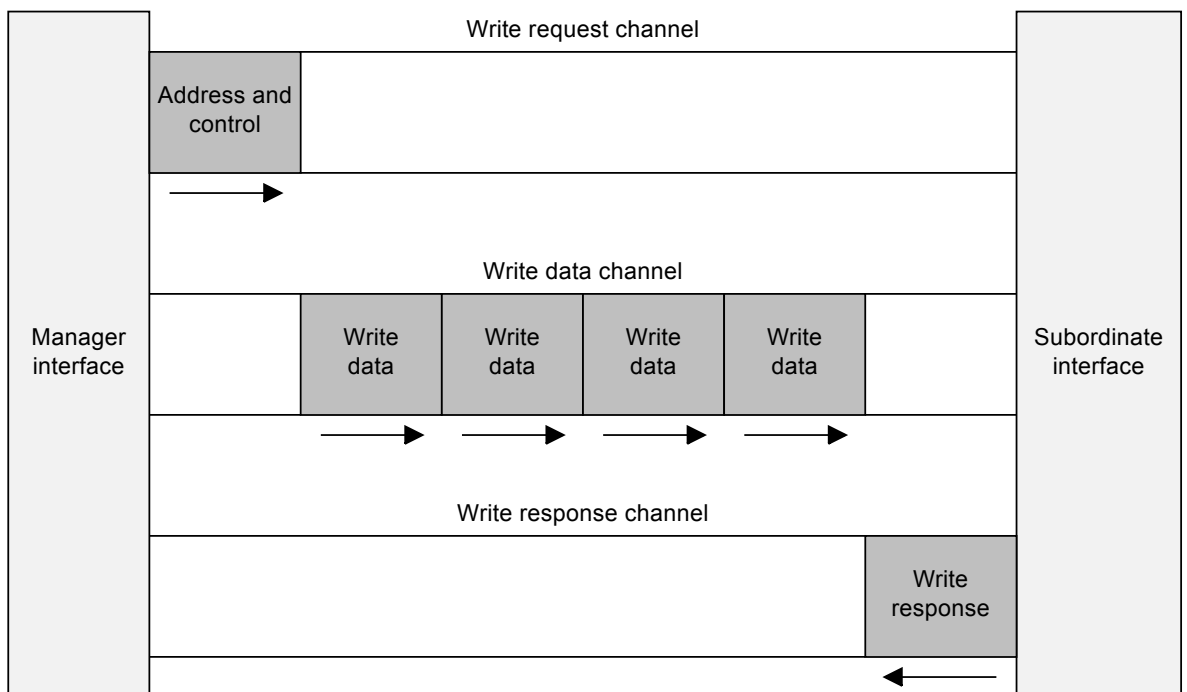

Figure A1.1: Channel architecture of writes

Figure A1.2 shows how a read transaction uses the read request and read data channels.

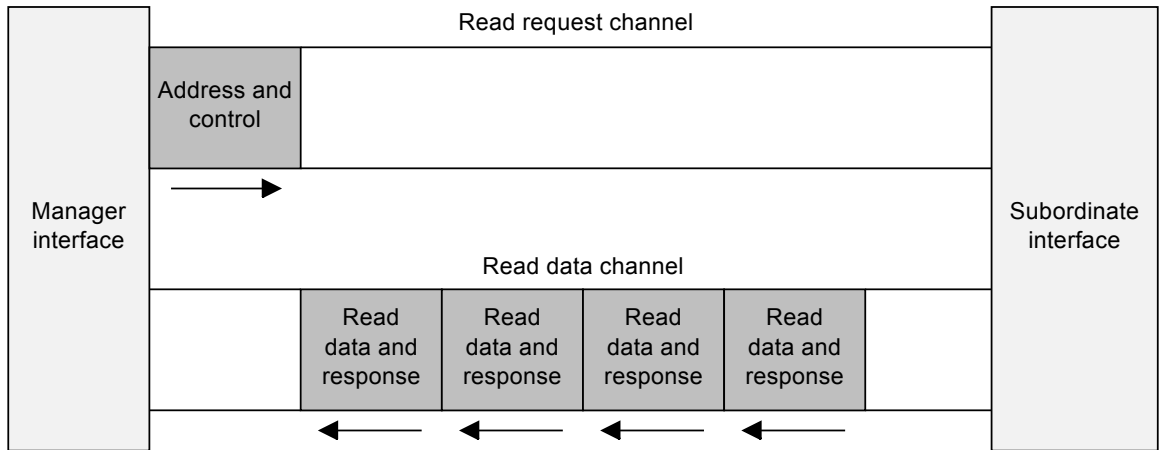

Figure A1.2: Channel architecture of reads

### A1.2.1 Channel definition

Each of the five independent channels consists of a set of information signals and **VALID** and **READY** signals that provide a two-way handshake mechanism.

The information source uses the **VALID** signal to show when valid address, data, or control information is available on the channel. The destination uses the **READY** signal to show when it can accept the information. Both the read data channel and the write data channel also include a **LAST** signal to indicate the transfer of the final data item in a transaction.

#### A1.2.1.1 Write and read request channels

There are separate write and read request channels. The appropriate request channel carries all the required address and control information for a transaction.

#### A1.2.1.2 Write data channel

The write data channel carries the write data from the Manager to the Subordinate and includes:

- The data signal, **WDATA** which can be 8, 16, 32, 64, 128, 256, 512, or 1024 bits wide. The width is indicated using the `DATA_WIDTH` property.
- A byte lane strobe signal for every eight data bits, indicating the bytes of the data that are valid.

Write data channel information is always treated as buffered, so that the Manager can perform write transactions without Subordinate acknowledgment of previous write transactions.

#### A1.2.1.3 Write response channel

A Subordinate uses the write response channel to respond to write transactions. All write transactions require completion signaling on the write response channel.

As [Figure A1.1](#) shows, completion is signaled only for a complete transaction, not for each data transfer in a transaction.

#### A1.2.1.4 Read data channel

The read data channel carries both the read data and the read response information from the Subordinate to the Manager and includes:

- The data signal, **RDATA** which can be 8, 16, 32, 64, 128, 256, 512, or 1024 bits wide. The width is indicated using the `DATA_WIDTH` property.
- A read response signal indicating the completion status of the read transaction.

### A1.2.2 Interface and interconnect

A typical system consists of several Manager and Subordinate devices that are connected together through some form of interconnect, as [Figure A1.3](#) shows.

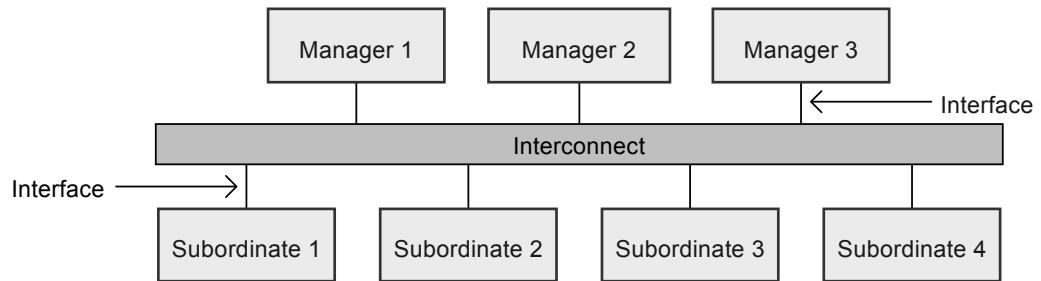

**Figure A1.3: Interface and interconnect**

The AXI protocol provides a single interface definition for the interfaces between:

- A Manager and the interconnect
- A Subordinate and the interconnect
- A Manager and a Subordinate

This interface definition supports many different interconnect implementations.

An interconnect between devices is equivalent to another device with symmetrical Manager and Subordinate ports that the real Manager and Subordinate devices can be connected.

#### A1.2.2.1 Typical system topologies

Most systems use one of three interconnect topologies:

- Shared request and data channels
- Shared request channel and multiple data channels
- Multilayer, with multiple request and data channels

In most systems, the request channel bandwidth requirement is significantly less than the data channel bandwidth requirement. Such systems can achieve a good balance between system performance and interconnect complexity by using a shared request channel with multiple data channels to enable parallel data transfers.



### A1.2.3 Register slices

Each AXI channel transfers information in only one direction, and the architecture does not require any fixed relationship between the channels. These qualities mean that a register slice can be inserted at almost any point in any channel at the cost of an additional cycle of latency.

These qualities make the following possible:

- Trade-off between cycles of latency and maximum frequency of operation.
- Direct, fast connection between a processor and high-performance memory, while using simple register slices to isolate longer paths to less performance critical peripherals.

## A1.3 Terminology

This section summarizes terms that are used in this specification, and are defined in [Chapter C1 Glossary](#), or elsewhere. Where appropriate, terms that are listed in this section link to the corresponding glossary definition.

### A1.3.1 AXI components and topology

The following terms describe AXI components:

- [Component](#)
- [Manager Component](#)
- [Subordinate Component](#), which includes [Memory Subordinate component](#) and [Peripheral Subordinate component](#)
- [Interconnect Component](#)

For a particular AXI transaction, [Upstream](#) and [Downstream](#) refer to the relative positions of AXI components within the AXI topology.

### A1.3.2 AXI transactions and transfers

An AXI transfer is the communication in one cycle on an AXI channel.

An AXI transaction is the set of transfers required for an AXI Manager to communicate with an AXI Subordinate. For example, a read transaction consists of a request transfer and one or more read data transfers.

### A1.3.3 Caches and cache operation

This specification does not define standard cache terminology that is defined in any reference work on caching.

However, the glossary entries for [Cache](#) and [Cache line](#) clarify how these terms are used in this document.

### A1.3.4 Temporal description

The AXI specification uses the term [in a timely manner](#).

## Chapter A2

# Signal list

This chapter lists all the signals described within this specification. Some channels and signals are optional, so are not included on every interface. Each signal name contains a hyperlink to the section in which the signal is defined.

Parity check signals are not included in this chapter but are listed in [A17.2.3 Parity check signals](#).

Signals are grouped based on channel and category as described in the following sections:

- [A2.1 Write channels](#)
- [A2.2 Read channels](#)
- [A2.3 Snoop channels](#)
- [A2.4 Interface level signals](#)

## A2.1 Write channels

The write channels are used to transfer requests, data, and responses for write transactions and some other data-less transactions.

### A2.1.1 Write request channel

The write request channel carries all the required address and control information for transactions that use the write channels. Signals on this channel have the prefix **AW**.

**Table A2.1: Write request channel signals**

Name	Width	Source	Description
AWVALID	1	Manager	Valid indicator
AWREADY	1	Subordinate	Ready indicator
AWID	ID_W_WIDTH	Manager	Transaction identifier for the write channels
AWADDR	ADDR_WIDTH	Manager	Transaction address
AWREGION	4	Manager	Region identifier
AWLEN	8	Manager	Transaction length
AWSIZE	3	Manager	Transaction size
AWBURST	2	Manager	Burst attribute
AWLOCK	1	Manager	Exclusive access indicator
AWCACHE	4	Manager	Memory attributes
AWPROT	3	Manager	Access attributes
AWNSE	1	Manager	Non-secure extension bit for RME
AWQOS	4	Manager	QoS identifier
AWUSER	USER_REQ_WIDTH	Manager	User-defined extension to a request
AWDOMAIN	2	Manager	Shareability domain of a request
AWSNOOP	AWSNOOP_WIDTH	Manager	Write request opcode
AWSTASHNID	11	Manager	Stash Node ID
AWSTASHNIDEN	1	Manager	Stash Node ID enable
AWSTASHLPID	5	Manager	Stash Logical Processor ID
AWSTASHLPIDEN	1	Manager	Stash Logical Processor ID enable
AWTRACE	1	Manager	Trace signal
AWLOOP	LOOP_W_WIDTH	Manager	Loopback signals on the write channels
AWMMUVALID	1	Manager	MMU signal qualifier
AWMMUSECSID	SECSID_WIDTH	Manager	Secure Stream ID
AWMMUSID	SID_WIDTH	Manager	StreamID

*Continued on next page*

Table A2.1 – Continued from previous page

Name	Width	Source	Description
AWMMUSSIDV	1	Manager	SubstreamID valid
AWMMUSSID	SSID_WIDTH	Manager	SubstreamID
AWMMUATST	1	Manager	Address translated indicator
AWMMUFLOW	2	Manager	SMMU flow type
AWPBHA	4	Manager	Page-based Hardware Attributes
AWNSAID	4	Manager	Non-secure Access ID
AWSUBSYSID	SUBSYSID_WIDTH	Manager	Subsystem ID
AWATOP	6	Manager	Atomic transaction opcode
AWMPAM	MPAM_WIDTH	Manager	MPAM information with a request
AWIDUNQ	1	Manager	Unique ID indicator
AWCMO	AWCMO_WIDTH	Manager	CMO type
AWTAGOP	2	Manager	Memory Tag operation for write requests
AWMECID	MECID_WIDTH	Manager	Memory Encryption Context identifier

### A2.1.2 Write data channel

The write data channel carries write data and control information from a Manager to a Subordinate. Signals on this channel have the prefix **W**.

Table A2.2: Write data channel signals

Name	Width	Source	Description
WVALID	1	Manager	Valid indicator
WREADY	1	Subordinate	Ready indicator
WDATA	DATA_WIDTH	Manager	Write data
WSTRB	DATA_WIDTH / 8	Manager	Write data strobes
WTAG	$\text{ceil}(\text{DATA\_WIDTH}/128)*4$	Manager	Memory Tag
WTAGUPDATE	$\text{ceil}(\text{DATA\_WIDTH}/128)$	Manager	Memory Tag update
WLAST	1	Manager	Last write data
WUSER	USER_DATA_WIDTH	Manager	User-defined extension to write data
WPOISON	$\text{ceil}(\text{DATA\_WIDTH} / 64)$	Manager	Poison indicator
WTRACE	1	Manager	Trace signal

### A2.1.3 Write response channel

The write response channel carries responses from Subordinate to Manager for transactions using the write data channels. Signals on this channel have the prefix **B**.

**Table A2.3: Write response channel signals**

Name	Width	Source	Description
<a href="#">BVALID</a>	1	Subordinate	Valid indicator
<a href="#">BREADY</a>	1	Manager	Ready indicator
<a href="#">BID</a>	ID_W_WIDTH	Subordinate	Transaction identifier for the write channels
<a href="#">BIDUNQ</a>	1	Subordinate	Unique ID indicator
<a href="#">BRESP</a>	BRESP_WIDTH	Subordinate	Write response
<a href="#">BCOMP</a>	1	Subordinate	Completion response indicator
<a href="#">BPERSIST</a>	1	Subordinate	Persist response
<a href="#">BTAGMATCH</a>	2	Subordinate	Memory Tag Match response
<a href="#">BUSER</a>	USER_RESP_WIDTH	Subordinate	User-defined extension to a write response
<a href="#">BTRACE</a>	1	Subordinate	Trace signal
<a href="#">BLOOP</a>	LOOP_W_WIDTH	Subordinate	Loopback signals on the write channels
<a href="#">BBUSY</a>	2	Subordinate	Busy indicator

## A2.2 Read channels

The read channels are used to transfer requests, data, and responses for read transactions, cache maintenance operations, and DVM Complete messages.

### A2.2.1 Read request channel

The read request channel carries all the required address and control information for transactions that use the read channels. Signals on this channel have the prefix **AR**.

**Table A2.4: Read request channel signals**

Name	Width	Source	Description
ARVALID	1	Manager	Valid indicator
ARREADY	1	Subordinate	Ready indicator
ARID	ID_R_WIDTH	Manager	Transaction identifier for the read channels
ARADDR	ADDR_WIDTH	Manager	Transaction address
ARREGION	4	Manager	Region identifier
ARLEN	8	Manager	Transaction length
ARSIZE	3	Manager	Transaction size
ARBURST	2	Manager	Burst attribute
ARLOCK	1	Manager	Exclusive access indicator
ARCACHE	4	Manager	Memory attributes
ARPROT	3	Manager	Access attributes
ARNSE	1	Manager	Non-secure extension bit for RME
ARQOS	4	Manager	QoS identifier
ARUSER	USER_REQ_WIDTH	Manager	User-defined extension to a request
ARDOMAIN	2	Manager	Shareability domain of a request
ARSNOOP	ARSNOOP_WIDTH	Manager	Read request opcode
ARTRACE	1	Manager	Trace signal
ARLOOP	LOOP_R_WIDTH	Manager	Loopback signals on the read channels
ARMMUVALID	1	Manager	MMU signal qualifier
ARMMUSECSID	SECSID_WIDTH	Manager	Secure Stream ID
ARMMUSID	SID_WIDTH	Manager	StreamID
ARMMUSSIDV	1	Manager	SubstreamID valid
ARMMUSSID	SSID_WIDTH	Manager	SubstreamID
ARMMUATST	1	Manager	Address translated indicator
ARMMUFLOW	2	Manager	SMMU flow type

*Continued on next page*

Table A2.4 – Continued from previous page

Name	Width	Source	Description
ARPBHA	4	Manager	Page-based Hardware Attributes
ARNSAID	4	Manager	Non-secure Access ID
ARSUBSYSID	SUBSYSID_WIDTH	Manager	Subsystem ID
ARMPAM	MPAM_WIDTH	Manager	MPAM information with a request
ARCHUNKEN	1	Manager	Read data chunking enable
ARIDUNQ	1	Manager	Unique ID indicator
ARTAGOP	2	Manager	Memory Tag operation for read requests
ARMECID	MECID_WIDTH	Manager	Memory Encryption Context identifier

### A2.2.2 Read data channel

The read data channel carries read data and responses from a Subordinate to a Manager. Signals on this channel have the prefix **R**.

Table A2.5: Read data channel signals

Name	Width	Source	Description
RVALID	1	Subordinate	Valid indicator
RREADY	1	Manager	Ready indicator
RID	ID_R_WIDTH	Subordinate	Transaction identifier for the read channels
RIDUNQ	1	Subordinate	Unique ID indicator
RDATA	DATA_WIDTH	Subordinate	Read data
RTAG	$\text{ceil}(\text{DATA\_WIDTH}/128)*4$	Subordinate	Memory Tag
RRESP	RRESP_WIDTH	Subordinate	Read response
RLAST	1	Subordinate	Last read data
RUSER	USER_DATA_WIDTH + USER_RESP_WIDTH	Subordinate	User-defined extension to read data and response
RPOISON	$\text{ceil}(\text{DATA\_WIDTH} / 64)$	Subordinate	Poison indicator
RTRACE	1	Subordinate	Trace signal
RLOOP	LOOP_R_WIDTH	Subordinate	Loopback signals on the read channels
RCHUNKV	1	Subordinate	Read data chunking valid
RCHUNKNUM	RCHUNKNUM_WIDTH	Subordinate	Read data chunk number
RCHUNKSTRB	RCHUNKSTRB_WIDTH	Subordinate	Read data chunk strobe
RBUSY	2	Subordinate	Busy indicator



## A2.3 Snoop channels

In this specification, the snoop channels are only used to transport DVM messages.

### A2.3.1 Snoop request channel

The snoop request channel carries address and control information for DVM message requests. Signals on this channel have the prefix **AC**.

**Table A2.6: Snoop request channel signals**

Name	Width	Source	Description
<a href="#">ACVALID</a>	1	Subordinate	Valid indicator
<a href="#">ACREADY</a>	1	Manager	Ready indicator
<a href="#">ACADDR</a>	ADDR_WIDTH	Subordinate	DVM message payload
<a href="#">ACVMIDEXT</a>	4	Subordinate	VMID extension for DVM messages
<a href="#">ACTRACE</a>	1	Subordinate	Trace signal

### A2.3.2 Snoop response channel

The snoop response channel carries responses to DVM messages. Signals on this channel have the prefix **CR**.

**Table A2.7: Snoop response channel signals**

Name	Width	Source	Description
<a href="#">CRVALID</a>	1	Manager	Valid indicator
<a href="#">CRREADY</a>	1	Subordinate	Ready indicator
<a href="#">CRTRACE</a>	1	Manager	Trace signal

## A2.4 Interface level signals

Interface level signals are non-channel signals. There can be up to one set of each per interface.

### A2.4.1 Clock and reset signals

All signals on an interface are synchronous to a global clock and are reset using a global reset signal.

**Table A2.8: Clock and reset signals**

Name	Width	Source	Description
<a href="#">ACLK</a>	1	External	Global clock signal
<a href="#">ARESETn</a>	1	External	Global reset signal

### A2.4.2 Wakeup signals

The wake-up signals are used to indicate that there is activity associated with the interface.

**Table A2.9: Wake-up signals**

Name	Width	Source	Description
<a href="#">AWAKEUP</a>	1	Manager	Wake-up signal associated with read and write channels
<a href="#">ACWAKEUP</a>	1	Subordinate	Wake-up signal associated with snoop channels

### A2.4.3 QoS Accept signals

QoS Accept signals can be used by a Subordinate interface to indicate the minimum QoS value of requests that it accepts.

**Table A2.10: QoS Accept signals**

Name	Width	Source	Description
<a href="#">VAWQOSACCEPT</a>	4	Subordinate	QoS acceptance level for write requests
<a href="#">VARQOSACCEPT</a>	4	Subordinate	QoS acceptance level for read requests

### A2.4.4 Coherency Connection signals

The coherency connection signals are used by a Manager to control whether it receives DVM messages on the AC channel.

**Table A2.11: Coherency connection signals**

Name	Width	Source	Description
<a href="#">SYSCOREQ</a>	1	Manager	Coherency connect request
<a href="#">SYSCOACK</a>	1	Subordinate	Coherency connect acknowledge

### A2.4.5 Interface control signals

The interface control signals are static inputs to a Manager interface that can be used to configure interface behavior.

**Table A2.12: Interface control signals**

Name	Width	Source	Description
<a href="#">BROADCASTATOMIC</a>	1	Tie-off	Control input for Atomic transactions
<a href="#">BROADCASTSHAREABLE</a>	1	Tie-off	Control input for Shareable transactions
<a href="#">BROADCASTCACHEMAINT</a>	1	Tie-off	Control input for cache maintenance operations
<a href="#">BROADCASTCMOPOPA</a>	1	Tie-off	Control input for the CleanInvalidPoPA CMO
<a href="#">BROADCASTPERSIST</a>	1	Tie-off	Control input for CleanSharedPersist and CleanSharedDeepPersist

## Chapter A3

# AXI Transport

This chapter describes the channel transport used in AXI.

It contains the following sections:

- [A3.1 Clock and reset](#)
- [A3.2 Channel handshake](#)
- [A3.3 Write and read channels](#)
- [A3.4 Relationships between the channels](#)
- [A3.5 Dependencies between channel handshake signals](#)
- [A3.6 Snoop channels](#)

## A3.1 Clock and reset

This section describes the requirements for implementing the AXI global clock and reset signals **ACLK** and **ARESETn**.

### A3.1.1 Clock

Each AXI interface has a single clock signal, **ACLK**. All input signals are sampled on the rising edge of **ACLK**. All output signal changes can only occur after the rising edge of **ACLK**.

On Manager and Subordinate interfaces, there must be no combinatorial paths between input and output signals.

### A3.1.2 Reset

The AXI protocol uses a single active-LOW reset signal, **ARESETn**. The reset signal can be asserted asynchronously, but deassertion can only be synchronous with a rising edge of **ACLK**.

During reset the following interface requirements apply:

- A Manager interface must drive **AWVALID**, **WVALID**, and **ARVALID** LOW.
- A Subordinate interface must drive **BVALID** and **RVALID** LOW.
- All other signals can be driven to any value.

The earliest point after reset that a Manager is permitted to begin driving **AWVALID**, **WVALID**, or **ARVALID** HIGH is at a rising **ACLK** edge after **ARESETn** is HIGH. Figure A3.1 shows the earliest point *b* after reset that **AWVALID**, **WVALID**, or **ARVALID**, can be driven HIGH.

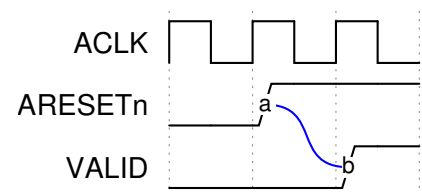

Figure A3.1: Exit from reset

## A3.2 Channel handshake

All AXI channels use the same **VALID/READY** handshake process to transfer address, data, and control information. This two-way flow control mechanism means both the Manager and Subordinate can control the rate that the information moves between Manager and Subordinate. The source generates the **VALID** signal to indicate when the address, data, or control information is available. The destination generates the **READY** signal to indicate that it can accept the information. Transfer occurs only when both the **VALID** and **READY** signals are **HIGH**.

On Manager and Subordinate interfaces, there must be no combinatorial paths between input and output signals. [Figure A3.2](#) to [Figure A3.4](#) show examples of the handshake process.

The source presents information after edge 1 and asserts the **VALID** signal as shown in [Figure A3.2](#). The destination asserts the **READY** signal after edge 2. The source must keep its information stable until the transfer occurs at edge 3, when this assertion is recognized.

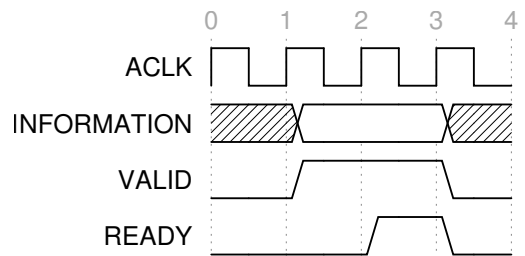

Figure A3.2: **VALID before READY** handshake

A source is not permitted to wait until **READY** is asserted before asserting **VALID**.

When **VALID** is asserted, it must remain asserted until the handshake occurs, at a rising clock edge when **VALID** and **READY** are both asserted.

In [Figure A3.3](#) the destination asserts **READY** after edge 1, before the address, data, or control information is valid. This assertion indicates that it can accept the information. The source presents the information and asserts **VALID** after edge 2, then the transfer occurs at edge 3, when this assertion is recognized. In this case, transfer occurs in a single cycle.

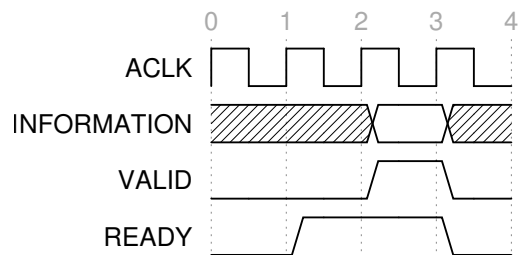
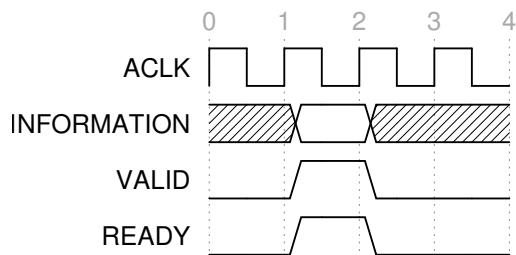

Figure A3.3: **READY before VALID** handshake

A destination is permitted to wait for **VALID** to be asserted before asserting the corresponding **READY**.

If **READY** is asserted, it is permitted to deassert **READY** before **VALID** is asserted.

In [Figure A3.4](#), both the source and destination happen to indicate that they can transfer the address, data, or control information after edge 1. In this case, the transfer occurs at the rising clock edge when the assertion of both **VALID** and **READY** can be recognized. These assertions mean that the transfer occurs at edge 2.



**Figure A3.4: VALID with READY handshake**

The individual AXI channel handshake mechanisms are described in [A3.4 Relationships between the channels](#).

## A3.3 Write and read channels

This section describes the AXI write and read channels. The channels are:

- [A3.3.1 Write request channel \(AW\)](#)
- [A3.3.2 Write data channel \(W\)](#)
- [A3.3.3 Write response channel \(B\)](#)
- [A3.3.4 Read request channel \(AR\)](#)
- [A3.3.5 Read data channel \(R\)](#)

For interfaces that use [A15.3 DVM messages](#), there are two additional channels:

- [A3.6.1 Snoop request channel \(AC\)](#)
- [A3.6.2 Snoop response channel \(CR\)](#)

### A3.3.1 Write request channel (AW)

The control signals for the write request channel are shown in [Table A3.1](#).

**Table A3.1: Write request channel control signals**

Name	Width	Source	Description
AWVALID	1	Manager	Write request valid indicator.
AWREADY	1	Subordinate	Write request ready indicator.

The Manager can assert the **AWVALID** signal only when it drives a valid request. When asserted, **AWVALID** must remain asserted until the rising clock edge after the Subordinate asserts **AWREADY**.

The default state of **AWREADY** can be either HIGH or LOW. It is recommended to use HIGH as the default state for **AWREADY**. When **AWREADY** is HIGH, the Subordinate must be able to accept any valid request that is presented to it.

It is not recommended to default **AWREADY** LOW because it forces the transfer to take at least two cycles, one to assert **AWVALID** and another to assert **AWREADY**.

### A3.3.2 Write data channel (W)

The control signals for the write data channel are shown in [Table A3.2](#).

**Table A3.2: Write data channel control signals**

Name	Width	Source	Description
WVALID	1	Manager	Write data valid indicator.
WREADY	1	Subordinate	Write data ready indicator.
WLAST	1	Manager	Indicates the last write data transfer of a transaction.

During a write transaction, the Manager can assert the **WVALID** signal only when it drives valid write data. When



asserted, **WVALID** must remain asserted until the rising clock edge after the Subordinate asserts **WREADY**.

The default state of **WREADY** can be HIGH, but only if the Subordinate can always accept write data in a single cycle.

The Manager must assert the **WLAST** signal while it is driving the final write transfer in the transaction.

It is recommended that **WDATA** is driven to zero for inactive byte lanes.

A Subordinate that does not use **WLAST** can omit the input from its interface.

The property `WLAST_Present` is used to determine if the **WLAST** signal is present.

**Table A3.3: WLAST\_Present property**

<b>WLAST_Present</b>	<b>Default</b>	<b>Description</b>
True	Y	WLAST is present.
False		WLAST is not present.

### A3.3.3 Write response channel (B)

The control signals for the write response channel are shown in [Table A3.4](#).

**Table A3.4: Write response channel control signals**

<b>Name</b>	<b>Width</b>	<b>Source</b>	<b>Description</b>
BVALID	1	Subordinate	Write response valid indicator.
BREADY	1	Manager	Write response ready indicator.

The Subordinate can assert the **BVALID** signal only when it drives a valid write response. When asserted, **BVALID** must remain asserted until the rising clock edge after the Manager asserts **BREADY**.

The default state of **BREADY** can be HIGH, but only if the Manager can always accept a write response in a single cycle.

### A3.3.4 Read request channel (AR)

The control signals for the read request channel are shown in [Table A3.5](#).

**Table A3.5: Read request channel control signals**

<b>Name</b>	<b>Width</b>	<b>Source</b>	<b>Description</b>
ARVALID	1	Manager	Read request valid indicator.
ARREADY	1	Subordinate	Read request ready indicator.

The Manager can assert the **ARVALID** signal only when it drives a valid request. When asserted, **ARVALID** must remain asserted until the rising clock edge after the Subordinate asserts the **ARREADY** signal.

The default state of **ARREADY** can be either HIGH or LOW. It is recommended to use HIGH as the default state for **ARREADY**. If **ARREADY** is HIGH, then the Subordinate must be able to accept any valid request that is presented to it.

It is not recommended to default **ARREADY** LOW because it forces the transfer to take at least two cycles, one to assert **ARVALID** and another to assert **ARREADY**.

### A3.3.5 Read data channel (R)

The control signals for the read data channel are shown in [Table A3.6](#).

**Table A3.6: Read data channel control signals**

Name	Width	Source	Description
RVALID	1	Subordinate	Read data valid indicator.
RREADY	1	Manager	Read data ready indicator.
RLAST	1	Subordinate	Indicates the last read data transfer of a transaction.

The Subordinate can assert the **RVALID** signal only when it drives valid signals on the read data channel. When asserted, **RVALID** must remain asserted until the rising clock edge after the Manager asserts **RREADY**. Even if a Subordinate has only one source of read data, it must assert the **RVALID** signal only in response to a request.

The Manager interface uses the **RREADY** signal to indicate that it accepts the data. The default state of **RREADY** can be HIGH, but only if the Manager is able to accept read data immediately when it starts a read transaction.

The Subordinate must assert the **RLAST** signal when it is driving the final read transfer in the transaction.

It is recommended that **RDATA** is driven to zero for inactive byte lanes.

A Manager that does not use **RLAST** can omit the input from its interface.

The property `RLAST_Present` is used to determine if the **RLAST** signal is present.

**Table A3.7: RLAST\_Present property**

RLAST_Present	Default	Description
True	Y	RLAST is present.
False		RLAST is not present.

## A3.4 Relationships between the channels

The AXI protocol requires the following relationships to be maintained:

- A write response must always follow the last write transfer in a write transaction.
- Read data and responses must always follow the read request.
- Channel handshakes must conform to the dependencies defined in [A3.5 Dependencies between channel handshake signals](#).
- When a Manager issues a write request, it must be able to provide all write data for that transaction, without dependency on other transactions from that Manager.
- When a Manager has issued a write request and all write data, it must be able to accept all responses for that transaction, without dependency on other transactions from that Manager.
- When a Manager has issued a read request, it must be able to accept all read data for that transaction, without dependency on other transactions from that Manager.
  - Note that a Manager can rely on read data returning in order from transactions that use the same ID, so the Manager only needs enough storage for read data from transactions with different IDs.
- A Manager is permitted to wait for one transaction to complete before issuing another transaction request.
- A Subordinate is permitted to wait for one transaction to complete before accepting or issuing transfers for another transaction.
- A Subordinate must not block acceptance of data-less write requests due to transactions with leading write data.

The protocol does not define any other relationship between the channels.

The lack of relationship means, for example, that the write data can appear at an interface before the write request for the transaction. This can occur if the write request channel contains more register stages than the write data channel. Similarly, the write data might appear in the same cycle as the request.

When the interconnect is required to determine the destination address space or Subordinate space, it must realign the request and write data. This realignment is required to assure that the write data is signaled as being valid only to the Subordinate that it is destined for.

## A3.5 Dependencies between channel handshake signals

There are dependencies between channels for write, read, and snoop transactions. These are described in the sections below and include dependency diagrams, where:

- Single-headed arrows point to signals that can be asserted before or after the signal at the start of the arrow.
- Double-headed arrows point to signals that must be asserted only after assertion of the signal at the start of the arrow.

### A3.5.1 Write transaction dependencies

For transactions on the write channels, [Figure A3.5](#) shows the handshake signal dependencies. The rules are:

- The Manager must not wait for the Subordinate to assert **AWREADY** or **WREADY** before asserting **AWVALID** or **WVALID**. This applies to every write data transfer in a transaction.
- The Subordinate can wait for **AWVALID** or **WVALID**, or both, before asserting **AWREADY**.
- The Subordinate can assert **AWREADY** before **AWVALID** or **WVALID**, or both, are asserted.
- The Subordinate can wait for **AWVALID** or **WVALID**, or both, before asserting **WREADY**.
- The Subordinate can assert **WREADY** before **AWVALID** or **WVALID**, or both, are asserted.
- The Subordinate must wait for **AWVALID**, **AWREADY**, **WVALID**, and **WREADY** to be asserted before asserting **BVALID**.
- The Subordinate must also wait for **WLAST** to be asserted before asserting **BVALID**. This wait is because the write response, **BRESP**, must be signaled only after the last data transfer of a write transaction.
- The Subordinate must not wait for the Manager to assert **BREADY** before asserting **BVALID**.
- The Manager can wait for **BVALID** before asserting **BREADY**.
- The Manager can assert **BREADY** before **BVALID** is asserted.

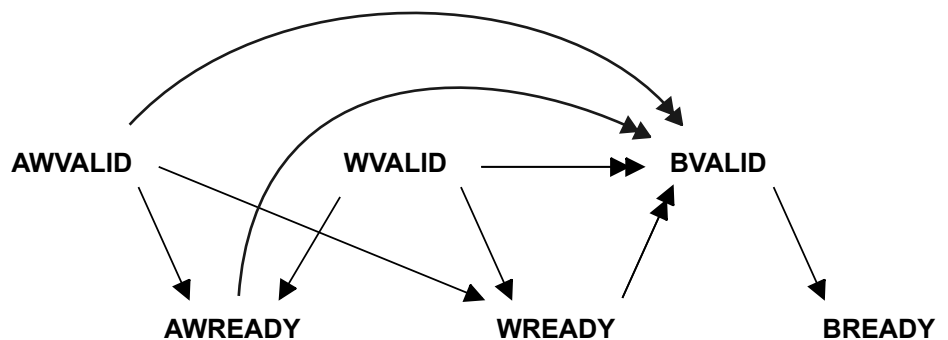

Figure A3.5: Write transaction handshake dependencies

### A3.5.2 Read transaction dependencies

For transactions on the read channels, [Figure A3.6](#) shows the handshake signal dependencies. The rules are:

- The Manager must not wait for the Subordinate to assert **ARREADY** before asserting **ARVALID**.
- The Subordinate can wait for **ARVALID** to be asserted before it asserts **ARREADY**.
- The Subordinate can assert **ARREADY** before **ARVALID** is asserted.

- The Subordinate must wait for both **ARVALID** and **ARREADY** to be asserted before it asserts **RVALID** to indicate that valid data is available.
- The Subordinate must not wait for the Manager to assert **RREADY** before asserting **RVALID**.
- The Manager can wait for **RVALID** to be asserted before it asserts **RREADY**.
- The Manager can assert **RREADY** before **RVALID** is asserted.

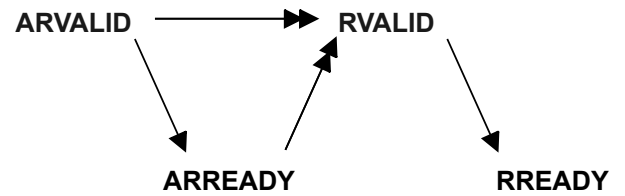

Figure A3.6: Read transaction handshake dependencies

## A3.6 Snoop channels

DVM messages are transported between interconnect and Manager components using snoop channels. When DVM messages are supported, there is a snoop request channel (AC) and snoop response channel (CR).

### A3.6.1 Snoop request channel (AC)

The control signals for the snoop request channel are shown in [Table A3.8](#).

**Table A3.8: Snoop request channel control signals**

Name	Width	Source	Description
ACVALID	1	Subordinate	Snoop request valid indicator.
ACREADY	1	Manager	Snoop request ready indicator.

A Subordinate can assert the **ACVALID** signal only when it drives valid address and control information. When asserted, **ACVALID** must remain asserted until the rising clock edge after the Manager asserts the **ACREADY** signal.

The default state of **ACREADY** can be either HIGH or LOW. It is recommended to use HIGH as the default state for **ACREADY**. If **ACREADY** is HIGH, then the Manager must be able to accept any valid request that is presented to it.

It is not recommended to default **ACREADY** LOW because it forces the transfer to take at least two cycles, one to assert **ACVALID** and another to assert **ACREADY**.

### A3.6.2 Snoop response channel (CR)

The control signals for the snoop response channel are shown in [Table A3.9](#).

**Table A3.9: Snoop response channel control signals**

Name	Width	Source	Description
CRVALID	1	Manager	Snoop response valid indicator.
CRREADY	1	Subordinate	Snoop response ready indicator.

The Manager can assert the **CRVALID** signal only when it drives valid signals on the snoop response channel. When asserted, **CRVALID** must remain asserted until the rising clock edge after the Subordinate asserts **CRREADY**.

The Subordinate interface uses the **CRREADY** signal to indicate that it accepts the response. The default state of **CRREADY** can be HIGH, but only if the Subordinate is able to accept the snoop response immediately when it starts a snoop transaction.

### A3.6.3 Snoop transaction dependencies

For transactions on the snoop channels, [Figure A15.2](#) shows the handshake signal dependencies. The rules are:

- The Subordinate must not wait for the Manager to assert **ACREADY** before asserting **ACVALID**.
- The Manager can wait for **ACVALID** to be asserted before it asserts **ACREADY**.
- The Manager can assert **ACREADY** before **ACVALID** is asserted.
- The Manager must wait for both **ACVALID** and **ACREADY** to be asserted before it asserts **CRVALID** to indicate that a valid response is available.
- The Manager must not wait for the Subordinate to assert **CRREADY** before asserting **CRVALID**.
- The Subordinate can wait for **CRVALID** to be asserted before it asserts **CRREADY**.
- The Subordinate can assert **CRREADY** before **CRVALID** is asserted.

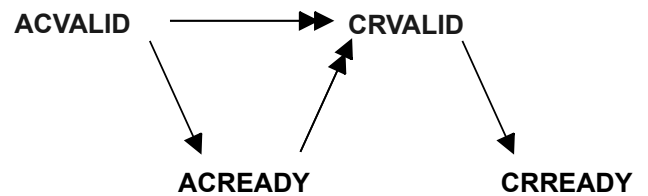

Figure A3.7: Snoop transaction handshake dependencies

## Chapter A4

# AXI Transactions

The AXI protocol uses transactions for communication between Managers and Subordinates. All transactions include a request and a response. Write and read transactions also include one or more data transfers.

This chapter describes the transaction requests, responses, and data transfers.

It contains the following sections:

- [A4.1 Transaction request](#)
- [A4.2 Write and read data](#)
- [A4.3 Transaction response](#)



## A4.1 Transaction request

An AXI Manager initiates a transaction by issuing a request to a Subordinate. A request includes transaction attributes and the address of the first data transfer. If the transaction includes more than one data transfer, the Subordinate must calculate the addresses of subsequent transfers.

A transaction must not cross a 4KB address boundary. This prevents a transaction from crossing a boundary between two Subordinates. It also limits the number of address increments that a Subordinate must support.

### A4.1.1 Size attribute

Size indicates the maximum number of bytes in each data transfer.

For read transactions, Size indicates how many data bytes must be valid in each read data transfer.

For write transactions, Size indicates how many data byte lanes are permitted to be active. The write strobes indicate which of those bytes are valid in each transfer.

Size must not exceed the data width of an interface, as determined by the DATA\_WIDTH property.

If Size is smaller than DATA\_WIDTH, a subset of byte lanes is used for each transfer.

Size is communicated using the **AWSIZE** and **ARSIZE** signals on the write request and read request channels, respectively. In this specification, **AxSIZE** indicates **AWSIZE** and **ARSIZE**.

**Table A4.1: AxSIZE signals**

Name	Width	Default	Description
AWSIZE, ARSIZE	3	DATA_WIDTH/8	Indicates the maximum number of bytes in each data transfer within a transaction.

Size is encoded on the **AxSIZE** signals as shown in [Table A4.2](#).

**Table A4.2: AxSIZE encodings**

AxSIZE	Label	Meaning
0b000	1	1 byte per transfer
0b001	2	2 bytes per transfer
0b010	4	4 bytes per transfer
0b011	8	8 bytes per transfer
0b100	16	16 bytes per transfer
0b101	32	32 bytes per transfer
0b110	64	64 bytes per transfer
0b111	128	128 bytes per transfer

The property SIZE\_Present is used to determine if the **AxSIZE** signals are present.

**Table A4.3: SIZE\_Present property**

SIZE_Present	Default	Description
True	Y	AWSIZE and ARSIZE are present.
False		AWSIZE and ARSIZE are not present.

A Manager that only issues requests of full data width can omit the **AxSIZE** outputs from its interface. An attached Subordinate must have its **AxSIZE** input tied according to the data width.

### A4.1.2 Length attribute

The Length attribute defines the number of data transfers in a transaction.

Size x Length is the maximum number of bytes that can be transferred in a transaction. If the address is unaligned or there are deasserted write strobes, the actual number of bytes transferred can be lower than Size x Length.

A Manager must issue the number of write data transfers according to Length.

A Subordinate must issue the number of read data transfers according to Length.

Length is communicated using the **AWLEN** and **ARLEN** signals on the write request and read request channels, respectively. In this specification, **AxLEN** indicates **AWLEN** and **ARLEN**.

**Table A4.4: AxLEN signals**

Name	Width	Default	Description
AWLEN, ARLEN	8	0x00	The total number of transfers in a transaction, encoded as: Length = AxLEN + 1.

The property LEN\_Present is used to determine if the signals are present. [Table A4.5](#) shows the legal values of LEN\_Present.

**Table A4.5: LEN\_Present property**

LEN_Present	Default	Description
True	Y	AWLEN and ARLEN are present.
False		AWLEN and ARLEN are not present.

A Manager that only issues requests of Length 1 can omit the **AxLEN** outputs from its interface. An attached Subordinate must have its **AxLEN** input tied to 0x00.

The following rules apply to transaction Length:

- For wrapping bursts, Length can be 2, 4, 8, or 16.
- For fixed bursts, Length can be up to 16.
- A transaction must not cross a 4KB address boundary.
- Early termination of transactions is not supported.

No component can terminate a transaction early. However, to reduce the number of data transfers in a write transaction, the Manager can disable further writing by deasserting all the write strobes. In this case, the Manager

must complete the remaining transfers in the transaction. In a read transaction, the Manager can discard read data, but it must complete all transfers in the transaction.

### A4.1.3 Maximum number of bytes in a transaction

The maximum number of bytes in a transaction is 4KB and transactions are not permitted to cross a 4KB boundary. However, many Managers generate transactions which are always smaller than this.

A Subordinate or interconnect might benefit from this information. For example, a Subordinate might be able to optimize away some decode logic. An interconnect striping at a granule smaller than 4KB might be able to avoid burst splitting if it knows that transactions will not cross the stripe boundary.

The property `Max_Transaction_Bytes` defines the maximum size of a transaction in bytes as shown in [Table A4.6](#).

**Table A4.6: Max\_Transaction\_Bytes property**

Name	Values	Default	Description
<code>Max_Transaction_Bytes</code>	64, 128, 256, 512, 1024, 2048, 4096	4096	A Manager issues transactions where <code>Size x Length</code> is <code>Max_Transaction_Bytes</code> or smaller and transactions do not cross a <code>Max_Transaction_Bytes</code> boundary. A Subordinate can only accept transactions where <code>Size x Length</code> is <code>Max_Transaction_Bytes</code> or smaller.

When connecting Manager and Subordinate interfaces, [Table A4.7](#) indicates combinations of `Max_Transaction_Bytes` that are compatible.

**Table A4.7: Max\_Transaction\_Bytes interoperability**

Manager < Subordinate	Manager == Subordinate	Manager > Subordinate
Compatible	Compatible	Not compatible

### A4.1.4 Burst attribute

The Burst attribute describes how the address increments between transfers in a transaction. There are three different Burst types:

#### **FIXED**

This Burst type is used for repeated accesses to the same location such as when loading or emptying a FIFO.

- The address is the same for every transfer in the burst.
- The byte lanes that are valid are constant for all transfers. However, within those byte lanes, the actual bytes that have **WSTRB** asserted can differ for each transfer.
- The Length of the burst can be up to 16 transfers.
- The FIXED burst type can only be used with `WriteNoSnoop` or `ReadNoSnoop` Opcodes. See [Chapter A8 Request Opcodes](#) for more information.

#### **INCR (incrementing)**

With this Burst type, the address for each transfer is an increment of the address for the previous transfer. The increment value depends on the transaction Size. For example, for an aligned start address, the address for each

transfer in a transaction with a Size of 4 bytes is the previous address plus 4. This Burst type is used for accesses to normal sequential memory.

**WRAP (wrapping)**

This Burst type is similar to INCR except that the address wraps around to a lower address if an upper address limit is reached. The following restrictions apply:

- The start address must be aligned to the size of each transfer.
- The Length of the burst must be 2, 4, 8, or 16 transfers.

The behavior of a wrapping transaction is:

- The lowest address accessed by the transaction is the start address aligned to the total size of the data to be transferred, that is  $\text{Size} * \text{Length}$ . This address is defined as the wrap boundary.
- After each transfer, the address increments in the same way as for an INCR burst. However, if this incremented address is  $((\text{wrap boundary}) + (\text{Size} * \text{Length}))$ , then the address wraps round to the wrap boundary.
- The first transfer in the transaction can use an address that is higher than the wrap boundary, subject to the restrictions that apply to wrapping transactions. The address wraps when the first address is higher than the wrap boundary. This Burst type is used for cache line accesses.

Burst is communicated using the **AWBURST** and **ARBURST** signals on the write request and read request channels, respectively. In this specification, **AxBURST** indicates **AWBURST** and **ARBURST**.

**Table A4.8: AxBURST signals**

Name	Width	Default	Description
AWBURST, ARBURST	2	0b01 (INCR)	Describes how the address increments between transfers in a transaction.

Burst is encoded on the **AxBURST** signals as shown in [Table A4.9](#).

**Table A4.9: AxBURST encodings**

AxBURST	Label	Meaning
0b00	FIXED	Fixed burst
0b01	INCR	Incrementing burst
0b10	WRAP	Wrapping burst
0b11	RESERVED	-

The property **BURST\_Present** is used to determine if the **AxBURST** signals are present.

A Manager that only issues requests with a Burst type of INCR can omit the **AxBURST** outputs from its interface. An attached Subordinate must have its **AxBURST** input tied to 0b01.

**Table A4.10: BURST\_Present property**

BURST_Present	Default	Description
True	Y	AWBURST and ARBURST are present.

False	AWBURST and ARBURST are not present.
-------	--------------------------------------

**Fixed\_Burst\_Disable**

A Burst type of FIXED is not commonly used, and a property Fixed\_Burst\_Disable is defined in [Table A4.11](#) to indicate if a component supports it.

**Table A4.11: Fixed\_Burst\_Disable property**

Fixed_Burst_Disable	Default	Description
True		Requests with Burst type FIXED are not supported by a Subordinate interface and not generated by a Manager interface.
False	Y	Requests with Burst type FIXED are supported by a Subordinate interface and might be generated by a Manager interface.

Compatibility between Manager and Subordinate interfaces, according to the values of the Fixed\_Burst\_Disable property is shown in [Table A4.12](#).

**Table A4.12: Fixed\_Burst\_Disable compatibility**

Fixed_Burst_Disable	Subordinate: False	Subordinate: True
Manager: False	Compatible.	Not compatible.
Manager: True	Compatible.	Compatible.

### A4.1.5 Transfer address

This section provides methods for determining the address and byte lanes of transfers within a transaction. The start address for a transaction is indicated using the **AxADDR** signals.

**Table A4.13: AxADDR signals**

Name	Width	Default	Description
AWADDR, ARADDR	ADDR_WIDTH	-	Address of first transfer in a transaction.

#### Address width

The property ADDR\_WIDTH is used to define the address width.

**Table A4.14: ADDR\_WIDTH property**

Name	Values	Default	Description
ADDR_WIDTH	1..64	32	Width of AWADDR, ARADDR, and ACADDR in bits.

The protocol supports communication between components that have different physical address space sizes. Components with different physical address space sizes must communicate as follows:

- The component with the smaller physical address space must be positioned within an aligned window in the larger physical address space. Typically, the window is located at the bottom of the larger physical address space. However, it is acceptable for the component with the smaller physical address space to be positioned in an offset window within the larger physical address space.
- An outgoing transaction must have the required additional higher-order bits added to the transaction address.
- An incoming transaction must be examined so that:
  - A transaction that is within the address window has the higher-order address bits removed and is passed through.
  - A transaction that does not have the required higher-order address bits is suppressed.

It is the responsibility of the interconnect to provide the required functionality.

### A4.1.6 Transaction equations

The equations listed here are used to determine the address and active data byte lanes for each transfer in a transaction. The equations use the following additional variables:

- *Start\_Addr*: The start address that is issued by the Manager.
- *Data\_Bytes*: The width of the data channels in bytes ( $DATA\_WIDTH/8$ ).
- *Aligned\_Addr*: The aligned version of the start address.
- *Address\_N*: The address of transfer N in a transaction. N is 1 for the first transfer in a transaction.
- *Wrap\_Boundary*: The lowest address within a wrapping transaction.
- *Lower\_Byte\_Lane*: The byte lane of the lowest addressed byte of a transfer.
- *Upper\_Byte\_Lane*: The byte lane of the highest addressed byte of a transfer.

- $\text{INT}(x)$ : The rounded-down integer value of  $x$ .

These equations determine addresses of transfers within a burst:

$$\text{Start\_Addr} = \text{AxADDR}$$

$$\text{Aligned\_Addr} = \text{INT}(\text{Start\_Addr} / \text{Size}) * \text{Size}$$

This equation determines the address of the first transfer in a burst:

$$\text{Address}_1 = \text{Start\_Addr}$$

For an INCR burst and for a WRAP burst for which the address has not wrapped, this equation determines the address of any transfer after the first transfer in a burst:

$$\text{Address}_N = \text{Aligned\_Addr} + (N - 1) * \text{Size}$$

For a WRAP burst, the `Wrap_Boundary` variable defines the wrapping boundary:

$$\text{Wrap\_Boundary} = \text{INT}(\text{Start\_Addr} / (\text{Size} * \text{Length})) * \text{Size} * \text{Length}$$

For a WRAP burst, if  $\text{Address}_N = \text{Wrap\_Boundary} + \text{Size} * \text{Length}$ , then:

- Use this equation for the current transfer:

$$\text{Address}_N = \text{Wrap\_Boundary}$$

- Use this equation for any subsequent transfers:

$$\text{Address}_N = \text{Start\_Addr} + ((N - 1) * \text{Size}) - (\text{Size} * \text{Length})$$

These equations determine the byte lanes to use for the first transfer in a burst:

$$\text{Lower\_Byte\_Lane} = \text{Start\_Addr} - (\text{INT}(\text{Start\_Addr}/\text{Data\_Bytes}) * \text{Data\_Bytes})$$

$$\text{Upper\_Byte\_Lane} = \text{Aligned\_Addr} + (\text{Size}-1) - (\text{INT}(\text{Start\_Addr}/\text{Data\_Bytes}) * \text{Data\_Bytes})$$

These equations determine the byte lanes to use for all transfers after the first transfer in a burst:

$$\text{Lower\_Byte\_Lane} = \text{Address}_N - (\text{INT}(\text{Address}_N / \text{Data\_Bytes}) * \text{Data\_Bytes})$$

$$\text{Upper\_Byte\_Lane} = \text{Lower\_Byte\_Lane} + \text{Size} - 1$$

Data is transferred on:

$$\text{DATA}((8 * \text{Upper\_Byte\_Lane}) + 7 : (8 * \text{Lower\_Byte\_Lane}))$$

The transaction container describes all the bytes that could be accessed in that transaction, if the address is aligned and strobes are asserted:

$$\text{Container\_Size} = \text{Size} * \text{Length}$$

For INCR bursts:

$$\text{Container\_Lower} = \text{Aligned\_Addr}$$

$$\text{Container\_Upper} = \text{Aligned\_Addr} + \text{Container\_Size}$$

For WRAP bursts:

$$\text{Container\_Lower} = \text{Wrap\_Boundary}$$

$$\text{Container\_Upper} = \text{Wrap\_Boundary} + \text{Container\_Size}$$

### A4.1.7 Pseudocode description of the transfers

---

```
// DataTransfer()
DataTransfer(Start_Addr, Size, Length, Data_Bytes, Burst, IsWrite)
// IsWrite is TRUE for a write, and FALSE for a read

    addr = Start_Addr; // Variable for current address
    Aligned_Addr = (INT(addr/Size) * Size);
    aligned = (Aligned_Addr == addr); // Check whether addr aligned to Size
    Container_Size = Size * Length;

    if Burst == WRAP then
        Lower_Wrap_Boundary = (INT(addr/Container_Size) * Container_Size);
        // addr must be aligned for a wrapping burst
        Upper_Wrap_Boundary = Lower_Wrap_Boundary + Container_Size;

    for n = 1 to Length
        Lower_Byte_Lane = addr - (INT(addr/Data_Bytes) * Data_Bytes);
        if aligned then
            Upper_Byte_Lane = Lower_Byte_Lane + Size - 1
        else
            Upper_Byte_Lane = Aligned_Addr + Size - 1
                - (INT(addr/Data_Bytes) * Data_Bytes);

        // Perform data transfer
        if IsWrite then
            dwrite(addr, Lower_Byte_Lane, Upper_Byte_Lane)
        else
            dread(addr, Lower_Byte_Lane, Upper_Byte_Lane);

        // Increment address if necessary
        if Burst != FIXED then
            if aligned then
                addr = addr + Size;
                if Burst == WRAP then
                    if addr >= Upper_Wrap_Boundary then addr = Lower_Wrap_Boundary;
            else
                addr = Aligned_Addr + Size;
                aligned = TRUE; // All transfers after the first are aligned

    return;
```

---



### A4.1.8 Regular transactions

There are many options of burst, size, and length for a transaction. However, some interfaces and transaction types might only use a subset of these options. If a Subordinate component is attached to a Manager which uses only a subset of transaction options, it can be designed with simplified decode logic.

The Regular attribute is defined, to identify transactions which meet the following criteria:

- Length is 1, 2, 4, 8, or 16 transfers.
- Size is the same as the data channel width if Length is greater than 1.
- Burst is INCR or WRAP, not FIXED.
- Address is aligned to the transaction container for INCR transactions.
- Address is aligned to Size for WRAP transactions.

The Regular\_Transactions\_Only property is used to define whether a Manager issues only Regular type transactions and if a Subordinate only supports Regular transactions.

**Table A4.15: Regular\_Transactions\_Only property**

Regular_Transactions_Only	Default	Description
True		Only Regular transactions are issued/supported.
False	Y	All legal combinations of Burst, Size, and Length are issued/supported.

Interoperability rules for Regular transactions are shown in [Table A4.16](#).

**Table A4.16: Regular\_Transactions\_Only interoperability**

	Subordinate: False	Subordinate: True
<b>Manager: False</b>	Compatible.	Not compatible. If the Manager issues a transaction that is not Regular, then data corruption or deadlock might occur.
<b>Manager: True</b>	Compatible.	Compatible.

## A4.2 Write and read data

This section describes the transfers of varying sizes on the AXI write and read data channels and how the interface performs mixed-endian and unaligned transfers.

### A4.2.1 Write strobes

The **WSTRB** signal carries write strobes that specify which byte lanes of the write data channel contain valid information.

**Table A4.17: WSTRB signal**

Name	Width	Default	Description
WSTRB	DATA_WIDTH / 8	All ones	Indicates which byte lanes of WDATA contain valid data in a write transaction.

There is one write strobe for each 8 bits of the write data channel, therefore **WSTRB[n]** corresponds to **WDATA[(8n)+7:(8n)]**.

When **WVALID** is HIGH:

- Data bytes to be written have a corresponding write strobe set HIGH.
- Inside of the transaction container any number of write strobes can be HIGH. If all write strobes are LOW, no data is written from that transfer.
- Outside of the transaction container all write strobes must be LOW.

When **WVALID** is LOW, the write strobes can take any value, although it is recommended that they are either driven LOW or held at their previous value.

It is recommended that **WDATA** is driven to zero for byte lanes where the strobe is LOW.

The property **WSTRB\_Present** is used to indicate if the **WSTRB** signal is present on an interface.

**Table A4.18: WSTRB\_Present property**

WSTRB_Present	Default	Description
True	Y	WSTRB is present.
False		WSTRB is not present.

A Manager that only issues transactions where all write strobes are asserted can omit the **WSTRB** output from its interface. An attached Subordinate must have its **WSTRB** input tied HIGH.

### A4.2.2 Narrow transfers

When a Manager generates a transfer that is narrower than its data channel, the address and control information determine the byte lanes that the transfer uses:

- When Burst is INCR or WRAP, different byte lanes are used for each data transfer in the transaction.
- When Burst is FIXED, the same byte lanes are used for each data transfer in the transaction.

Two examples of byte lane use are shown in [Figure A4.1](#) and [Figure A4.2](#). The shaded cells indicate bytes that are not transferred.

In [Figure A4.1](#):

- The transaction has five data transfers.
- The starting address is 0.
- Each transfer is 8 bits.
- The transfers are on a 32-bit data channel.
- The burst type is INCR.

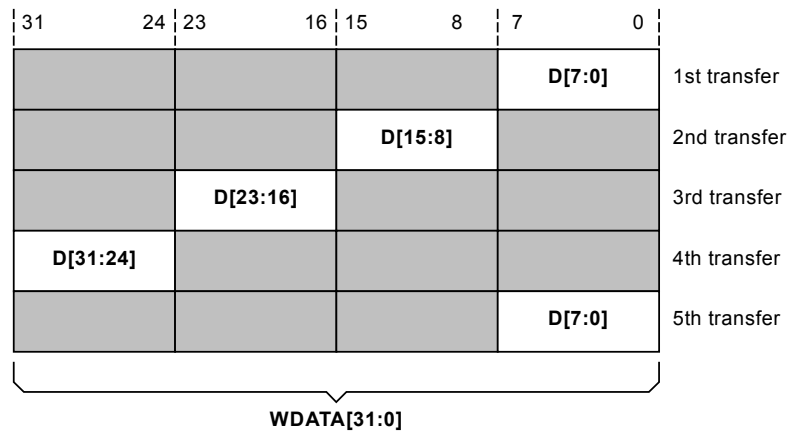

**Figure A4.1: Narrow transfer example with 8-bit transfers**

In [Figure A4.2](#):

- The transaction has three data transfers.
- The starting address is 4.
- Each transfer is 32 bits.
- The transfers are on a 64-bit data channel.

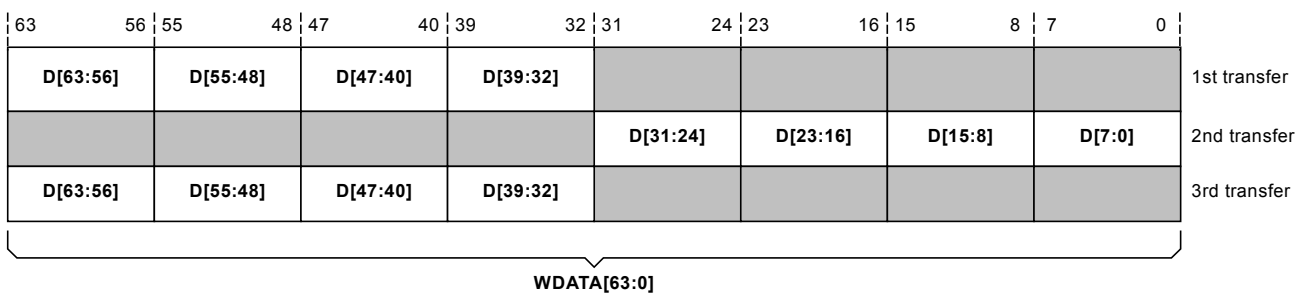

**Figure A4.2: Narrow transfer example with 32-bit transfers**

### A4.2.3 Byte invariance

To access mixed-endian data structures in a single memory space, the AXI protocol uses a byte-invariant endianness scheme.

Byte-invariant endianness means that for any multi-byte element in a data structure:

- The element uses the same continuous bytes of memory, regardless of the endianness of the data.
- The endianness determines the order of those bytes in memory, meaning it determines whether the first byte in memory is the *most significant byte* (MSB) or the *least significant byte* (LSB) of the element.
- Any byte transfer to an address passes the 8 bits of data on the same data channel wires to the same address location, regardless of the endianness of any larger data element that it is a constituent of.

Components that have only one transfer width must have their byte lanes connected to the appropriate byte lanes of the data channel. Components that support multiple transfer widths might require a more complex interface to convert an interface that is not naturally byte-invariant.

Most little-endian components can connect directly to a byte-invariant interface. Components that support only big-endian transfers require a conversion function for byte-invariant operation.

The examples in [Figure A4.3](#) and [Figure A4.4](#) show a 32-bit number  $0x0A0B0C0D$ , stored in a register and in a memory.

In [Figure A4.3](#) there is an example of the big-endian, byte-invariant data structure. In this structure:

- The MSB of the data, which is  $0x0A$ , is stored in the MSB position in the register.
- The MSB of the data is stored in the memory location with the lowest address.
- The other data bytes are positioned in decreasing order of significance.

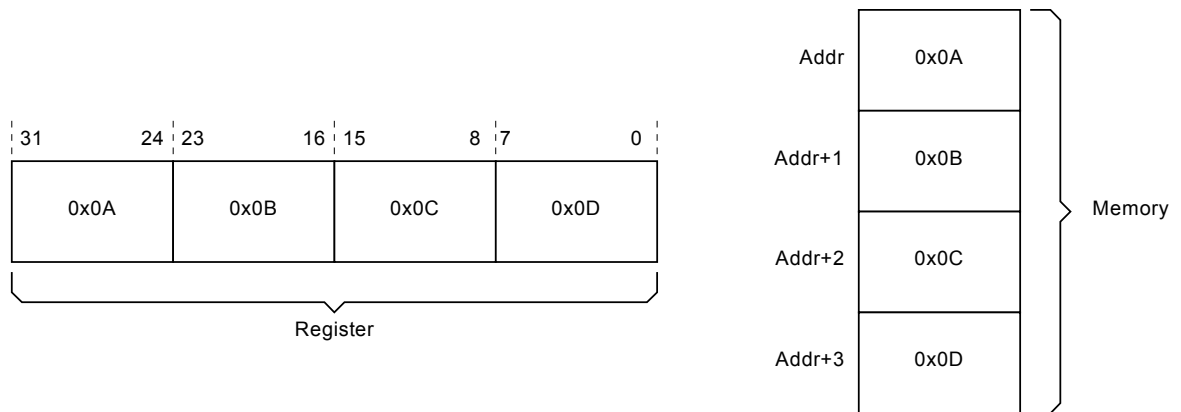

**Figure A4.3: Example big-endian byte-invariant data structure**

In [Figure A4.4](#) there is an example of a little-endian, byte-invariant data structure. In this structure:

- The LSB of the data, which is  $0x0D$ , is stored in the LSB position in the register.
- The LSB of the data is stored in the memory location with the lowest address.
- The other data bytes are positioned in increasing order of significance.

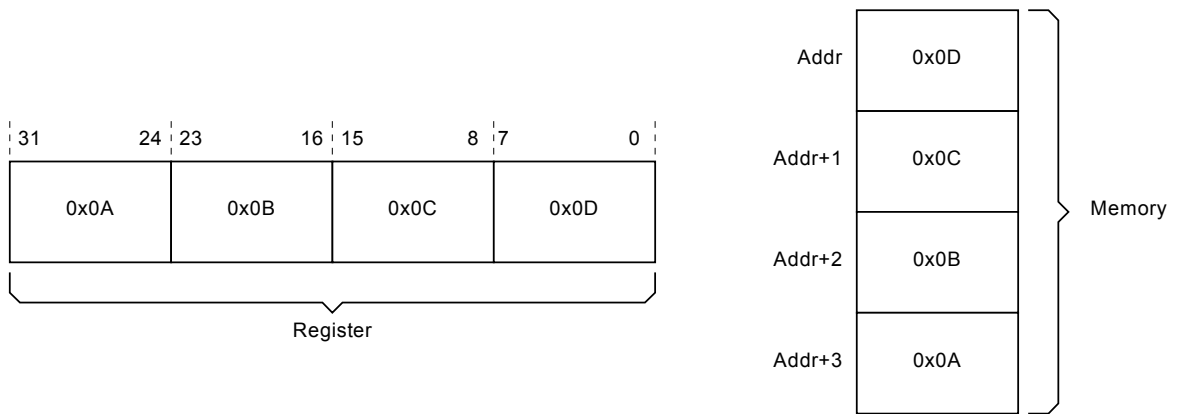

**Figure A4.4: Example little-endian byte-invariant data structure**

The examples in [Figure A4.3](#) and [Figure A4.4](#) show that byte invariance ensures that big-endian and little-endian structures can coexist in a single memory space without corruption.

In [Figure A4.5](#) there is an example of a data structure that requires byte-invariant access. In this example, the header fields use little-endian ordering, and the payload uses big-endian ordering.

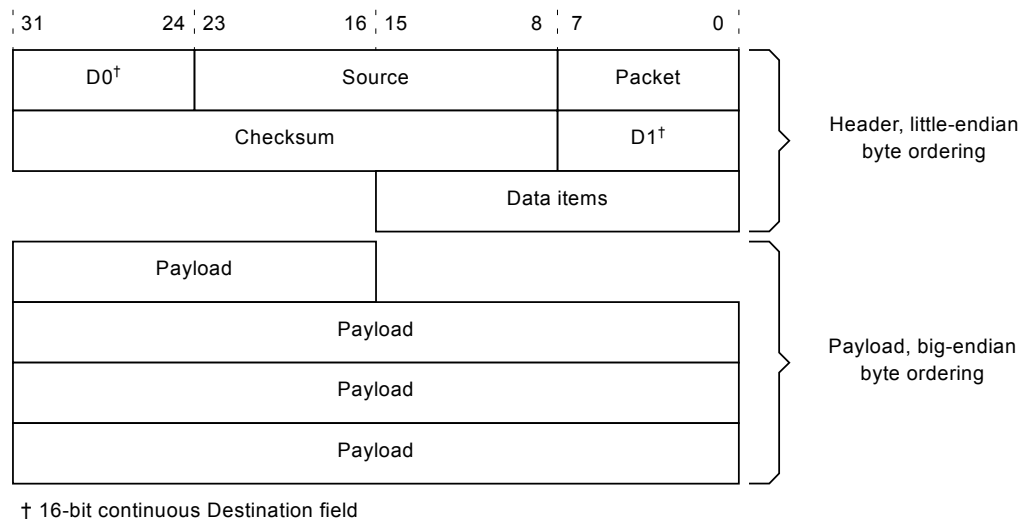

**Figure A4.5: Example mixed-endian data structure**

In this example structure, Data items is a two-byte little-endian element, meaning its lowest address is its LSB. The use of byte invariance ensures that a big-endian access to the payload does not corrupt the little-endian element.

#### A4.2.4 Unaligned transfers

AXI supports unaligned transfers. For any transaction that is made up of data transfers wider than 1 byte, the first bytes accessed might be unaligned with the natural address boundary. For example, a 32-bit data packet that starts at a byte address of 0x1002 is not aligned to the natural 32-bit address boundary.

A Manager can:

- Use the low-order address lines to signal an unaligned start address.

- Provide an aligned address and use the byte lane strobes to signal the unaligned start address.

The information on the low-order address lines must be consistent with the information on the byte lane strobes.

The Subordinate is not required to take special action based on any alignment information from the Manager.

In [Figure A4.6](#) there are examples of aligned and unaligned 32-bit transactions on a 32-bit data channel. Each row in the figure represents a transfer and the shaded cells indicate bytes that are not transferred.

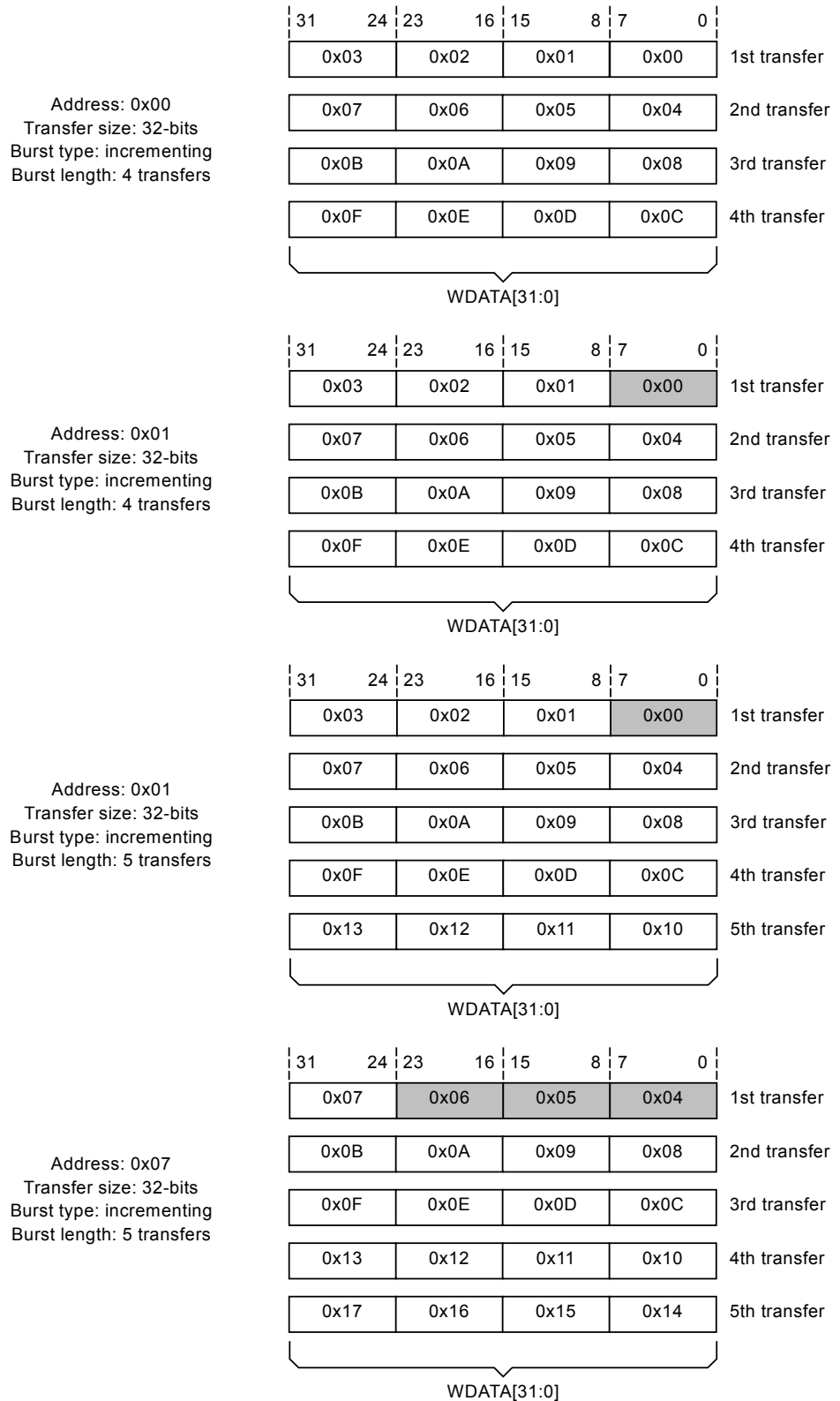

**Figure A4.6: Aligned and unaligned transfers on a 32-bit data channel**

In [Figure A4.7](#) there are examples of aligned and unaligned 32-bit transactions on a 64-bit data channel. Each row

in the figure represents a transfer and the shaded cells indicate bytes that are not transferred.

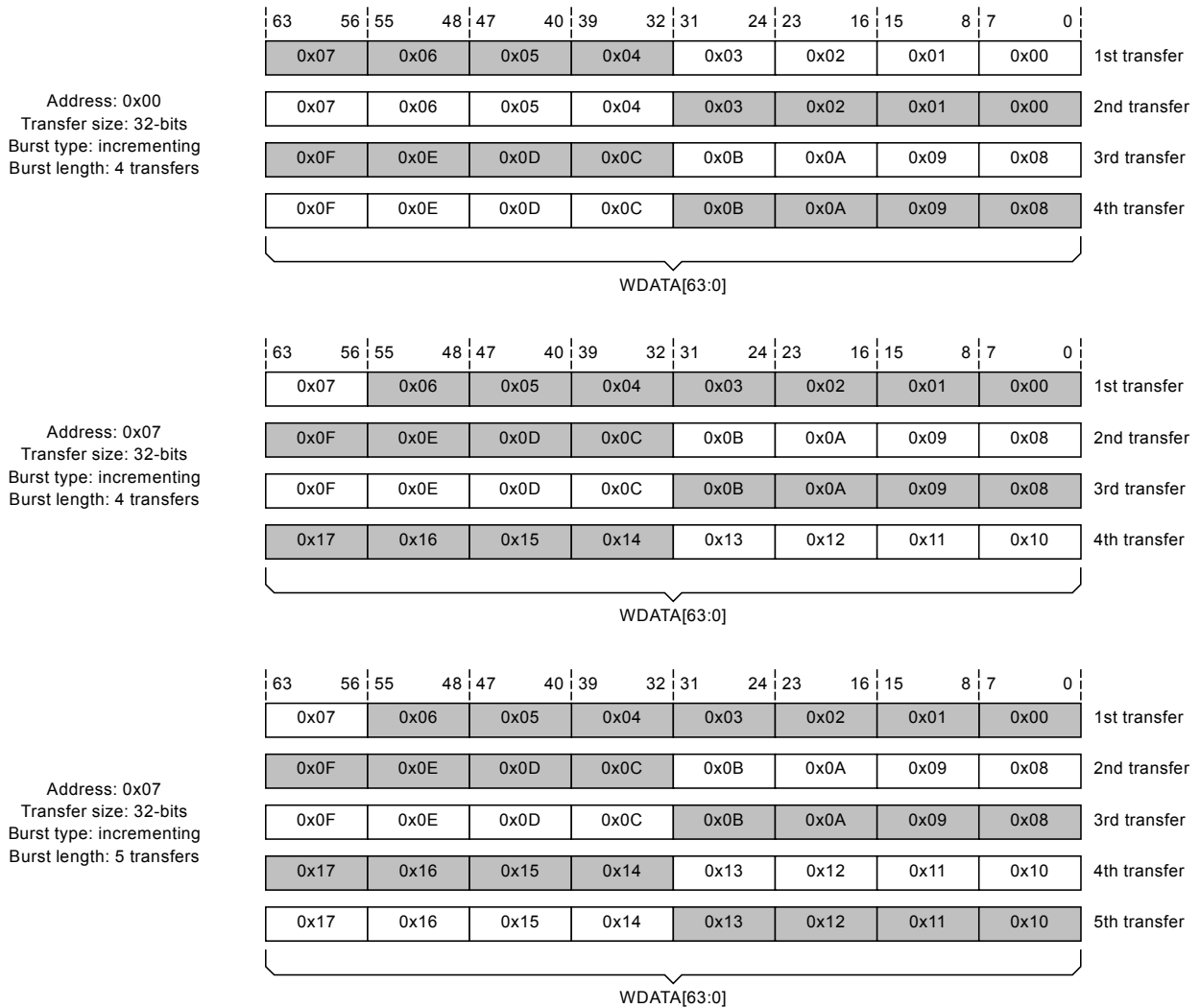

**Figure A4.7: Aligned and unaligned transfers on a 64-bit data channel**

In [Figure A4.8](#) there is an example of an aligned 32-bit wrapping transaction on a 64-bit data channel. Each row in the figure represents a transfer and the shaded cells indicate bytes that are not transferred.

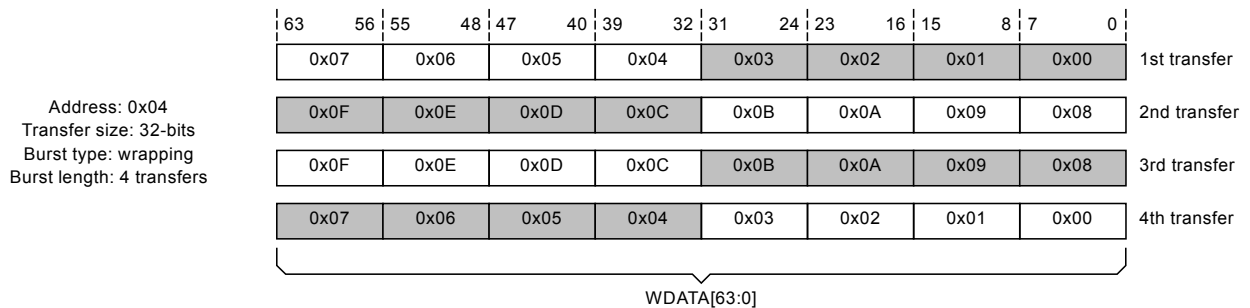

**Figure A4.8: Aligned wrapping transfers on a 64-bit channel**



## A4.3 Transaction response

Every AXI transaction includes one or more response transfers sent by the Subordinate to indicate the result of the transaction.

Transactions on the write channels have one or more write responses.

Transactions on the read channels have one or more read responses.

Atomic transactions have write and read responses, see [A7.4 Atomic transactions](#).

### A4.3.1 Write response

Write responses are transported using the **BRESP** signal on the write response channel. All transactions on the write channels have one Completion response which indicates the result of the transaction. Some transactions also have a second write response, for example to indicate Persistence, see [A10.8.4 PCMO response on the B channel](#).

The **BRESP** and **BCOMP** signals are used to send write responses.

**Table A4.19: BRESP and BCOMP signals**

Name	Width	Default	Description
BRESP	BRESP_WIDTH	0b000 (OKAY)	Indicates the result of a transaction that uses the write channels.
BCOMP	1	0b1	Asserted HIGH to indicate a Completion response.

The BRESP\_WIDTH property is defined in [Table A4.20](#).

**Table A4.20: BRESP\_WIDTH property**

Name	Values	Default	Description
BRESP_WIDTH	0, 2, 3	2	Width of BRESP in bits. Must be 3 if: Untranslated_Transactions = v2 OR Untranslated_Transactions = v3 OR WriteDeferrable_Transaction = True

**BRESP** is an optional signal. If the BRESP\_WIDTH property is 0, it is not present and assumed to be 0b000 (OKAY).

**BCOMP** is only present if an interface is using a feature that can have two write responses, these are:

- Cache maintenance for Persistence, see [A10.8 CMOs for Persistence](#).
- Memory Tagging, see [A13.2 Memory Tagging Extension \(MTE\)](#).

If **BCOMP** is present, it must be asserted for one response transfer of every transaction on the write channels.

The **BRESP** encodings are shown in [Table A4.21](#).

**Table A4.21: BRESP encodings**

BRESP	Label	Meaning
0b000	OKAY	Non-exclusive write: The transaction was successful. If the transaction includes write data, the updated value is observable. <b>Exclusive write</b> : Failed to update the location.
0b001	EXOKAY	<b>Exclusive write</b> succeeded. This response is only permitted for an exclusive write.
0b010	SLVERR	The request has reached an end point but has not completed successfully. The location might not be fully updated. Typically used when there is a problem within a Subordinate such as trying to access a read-only or powered-down function.
0b011	DECERR	The request has not reached a point where data can be written. The location might not be fully updated. Typically used when the address decodes to an invalid address.
0b100	DEFER	Write was unsuccessful because it cannot be serviced at this time. The location is not updated. This response is only permitted for a <b>WriteDeferrable</b> transaction.
0b101	TRANSFAULT	Write was terminated because of a translation fault which might be resolved by a <b>PRI</b> request.
0b110	RESERVED	-
0b111	UNSUPPORTED	Write was unsuccessful because the transaction type is not supported by the target. The location is not updated. This response is only permitted for a <b>WriteDeferrable</b> transaction.

### A4.3.2 Read response

The read response indicates if the read was successful and whether the data in that transfer is valid.

Read responses are transported using the **RRESP** signal on the read data channel. There is a read response with every read data transfer in a transaction. The response value is not required to be the same for every read data transfer in a transaction.

It is required that all data transfers as indicated by Length are always completed irrespective of the response. For some responses, the data in that transfer is not required to be valid.

The **RRESP** signal is defined in [Table A4.22](#).

**Table A4.22: RRESP signal**

Name	Width	Default	Description
RRESP	RRESP_WIDTH	0b000 (OKAY)	Response for transactions on the read channels. Must be valid when RVALID is asserted.

The RRESP\_WIDTH property is defined in [Table A4.23](#).

**Table A4.23: RRESP\_WIDTH property**

Name	Values	Default	Description
RRESP_WIDTH	0, 2, 3	2	Width of RRESP in bits. Must be 3 if Prefetch_Transaction = True OR Untranslated_Transactions = v2 OR Untranslated_Transactions = v3 OR Shareable_Cache_Support = True

**RRESP** is an optional signal. If the RRESP\_WIDTH property is 0, it is not present and assumed to be 0b000 (OKAY).

The **RRESP** encodings are shown in [Table A4.24](#).

For responses where data is not required to be valid, the Manager might still sample the **RDATA** value so the Subordinate should not rely on the response to hide sensitive data.

**Table A4.24: RRESP encodings**

RRESP	Label	Meaning
0b000	OKAY	Non-exclusive read: Transaction has completed successfully, read data is valid. <b>Exclusive read</b> : Subordinate does not support exclusive accesses.
0b001	EXOKAY	<b>Exclusive read</b> succeeded. This response is only permitted for an exclusive read.
0b010	SLVERR	Transaction has encountered a contained error; only this location is affected. Typically used when there is a problem within a Subordinate such as a FIFO overrun, unsupported transfer size or trying to access a powered-down function. Read data is not valid.
0b011	DECERR	Transaction has encountered a non-contained error; other locations may be affected. Typically used when the address decodes to an invalid address. Read data is not valid.
0b100	PREFETCHED	Read data is valid and has been sourced from a <b>prefetched</b> value.
0b101	TRANSFAULT	Transaction was terminated because of a translation fault which might be resolved by a <b>PRI</b> request. Read data is not valid.
0b110	OKAYDIRTY	Read data is valid and is Dirty with respect to the value in memory. Only permitted for a response to a <b>ReadShared</b> request.
0b111	RESERVED	-

The value of **RRESP** is not constrained to be the same for every transfer in a transaction. A response of DECERR is generally used when there is a problem accessing a Subordinate, and in this case DECERR is signaled consistently in every transfer of read data. There may be a benefit if a Manager can inspect just one read data transfer to determine whether a DECERR has occurred.

The Consistent\_DECERR property is used to define whether a Subordinate signals DECERR consistently within a transaction as shown in [Table A4.25](#).

**Table A4.25: Consistent\_DECERR property**

Consistent_DECERR	Default	Description
True		DECERR is signaled for every read data transfer, or no read data transfers in each cache line of data. For example, a transaction which crosses a cache line boundary can receive a DECERR response for every read data transfer on one cache line and no data transfers on the next cache line.
False	Y	DECERR may be signaled on any number of read data transfers.

A Subordinate interface that does not use the DECERR response can set the Consistent\_DECERR property to True.

A Manager with Consistent\_DECERR set True can inspect a single data transfer to determine whether a DECERR has occurred.

Setting this property to True can be helpful when bridging between AXI and CHI where DECERR translates to a Non-data Error.

When connecting Manager and Subordinate interfaces, [Table A4.26](#) indicates combinations of Consistent\_DECERR that are compatible.

**Table A4.26: Consistent\_DECERR interoperability**

	Subordinate: False	Subordinate: True
Manager: False	Compatible.	Compatible.
Manager: True	Not compatible. A DECERR response might be missed by the Manager.	Compatible.

### A4.3.3 Subordinate Busy indicator

When providing a response, a Subordinate can indicate its current level of activity using the Busy indicator. This information can be used to control the issue rate of a Manager or how many speculative transactions it produces.

The Busy indication is useful for components with a shared resource, such as a memory controller or system cache. For example, the Busy indication can indicate:

- The level of a shared queue.
- The level of a read or write request queue, depending on the direction of the transaction.
- When the resource usage by a component is more or less than its allocated value.

The Busy\_Support property as shown in [Table A4.27](#) is used to define whether an interface includes the Busy indicator signals.

**Table A4.27: Busy\_Support property**

Busy_Support	Default	Description
True		Subordinate busy is supported.
False	Y	Subordinate busy is not supported.

When Busy\_Support is True, the following signals are included on an interface.

**Table A4.28: Busy indicator signals**

Name	Width	Default	Description
BBUSY, RBUSY	2	0b00	Indicates the current level of Subordinate activity in a transaction response. The value increases as the Subordinate becomes busier.

For transactions with multiple read data transfers, Busy must be valid but can take a different value for every transfer.

For transactions with multiple write responses, Busy must be valid in the response with **BCOMP** asserted. For other write responses, Busy is not-applicable and can take any value.

For Atomic transactions with write and read responses, **BBUSY** and **RBUSY** are expected, but not required to have the same value.

The exact usage of Busy indicator values is IMPLEMENTATION DEFINED, in [Table A4.29](#) there is an example of how it can be used. In this example, a default value of 0b01 would be appropriate if a Subordinate was not able to generate a dynamic busy indicator.

**Table A4.29: Example usage of the Busy indicator**

Busy indicator value	Meaning	Manager behavior
0b00	Not busy	Increase speculative requests
0b01	Optimally busy	No change
0b10	Quite busy	Decrease speculative requests
0b11	Very busy	Heavily decrease speculative requests

When connecting Manager and Subordinate interfaces, [Table A4.30](#) indicates combinations of Busy\_Support that are compatible.

**Table A4.30: Busy\_Support interoperability**

	Subordinate: False	Subordinate: True
Manager: False	Compatible.	Compatible, BUSY outputs are left unconnected.
Manager: True	Compatible, BUSY inputs are tied to the default value.	Compatible.

## Chapter A5

# Request attributes

This chapter describes request attributes that indicate how the request should be handled by downstream components. It contains the following sections:

- [A5.1 Subordinate types](#)
- [A5.2 Memory Attributes](#)
- [A5.3 Memory types](#)
- [A5.4 Protocol errors](#)
- [A5.5 Memory protection and the Realm Management Extension](#)
- [A5.6 Memory Encryption Contexts](#)
- [A5.7 Multiple region interfaces](#)
- [A5.8 QoS signaling](#)

## A5.1 Subordinate types

Subordinates are classified as either a Memory Subordinate or a Peripheral Subordinate.

### **Memory Subordinate**

A Memory Subordinate is required to handle all transaction types correctly.

### **Peripheral Subordinate**

A Peripheral Subordinate has an IMPLEMENTATION DEFINED method of access. Typically, the method of access is defined in the component data sheet that describes the transaction types that the Subordinate handles correctly.

Any access to the Peripheral Subordinate that is not part of the IMPLEMENTATION DEFINED method of access must complete, in compliance with the protocol. However, when such an access has been made, there is no requirement that the Peripheral Subordinate continues to operate correctly. The Subordinate is only required to continue to complete further transactions in a protocol-compliant manner.

## A5.2 Memory Attributes

This section describes the attributes that determine how a request should be treated by system components such as caches, buffers, and memory controllers.

The **AWCACHE** and **ARCACHE** signals specify the memory attributes of a request. They control:

- How a transaction progresses through the system.
- How any system-level buffers and caches handle the transaction.

In this specification, the term **AxCACHE** refers collectively to the **AWCACHE** and **ARCACHE** signals. [Table A5.1](#) describes the **AWCACHE** and **ARCACHE** signals.

**Table A5.1: AxCACHE signals**

Name	Width	Default	Description
AWCACHE, ARCACHE	4	0x0	The memory attributes of a request control how a transaction progresses through the system and how caches and buffers handle the request.

The property **CACHE\_Present** is used to determine if the **AxCACHE** signals are present on an interface.

**Table A5.2: CACHE\_Present property**

CACHE_Present	Default	Description
True	Y	AWCACHE and ARCACHE are present.
False		AWCACHE and ARCACHE are not present.

**AWCACHE** bits are encoded as:

- [0] Bufferable
- [1] Modifiable
- [2] Other Allocate
- [3] Allocate

**ARCACHE** bits are encoded as:

- [0] Bufferable
- [1] Modifiable
- [2] Allocate
- [3] Other Allocate

Note that the Allocate and Other Allocate bits are in different positions for read and write requests.

### A5.2.1 Bufferable, AxCACHE[0]

For write transactions:

- If the Bufferable bit is deasserted, the write response indicates that the data has reached its final destination.
- If the Bufferable bit is asserted, the write response can be sent from an intermediate point, when the observability requirements have been met.



For read transactions where **ARCACHE[3:2]** are deasserted (Non-cacheable) and **ARCACHE[1]** is asserted (Modifiable):

- If the Bufferable bit is deasserted, the read data must be obtained from the final destination.
- If the Bufferable bit is asserted, the read data can be obtained from the final destination or from a write that is progressing to the final destination.

For other combinations of **ARCACHE[3:1]**, the Bufferable bit has no effect.

## A5.2.2 Modifiable, **AxCACHE[1]**

When **AxCACHE[1]** is asserted, the transaction is Modifiable which indicates that the characteristics of the transaction can be modified. When **AxCACHE[1]** is deasserted, the transaction is Non-modifiable.

The following sections describe the properties of Non-modifiable and Modifiable transactions.

### **Non-modifiable transactions**

A Non-modifiable transaction must not be split into multiple transactions or merged with other transactions.

In a Non-modifiable transaction, the parameters that are shown in [Table A5.3](#) must not be changed.

**Table A5.3: Parameters fixed as Non-modifiable**

Parameter	Signals
Address	<b>AxADDR</b> , and therefore <b>AxREGION</b>
Size	<b>AxSIZE</b>
Length	<b>AxLEN</b>
Burst type	<b>AxBURST</b>
Protection attributes	<b>AxPROT</b> , <b>AxNSE</b>

The **AxCACHE** attribute can only be modified to convert a transaction from being Bufferable to Non-bufferable. No other change to **AxCACHE** is permitted.

The transaction ID and the QoS values can be modified.

A Non-modifiable transaction with Length greater than 16 can be split into multiple transactions. Each resulting transaction must meet the requirements that are given in this subsection, except that:

- The Length is reduced.
- The address of the generated transactions is adapted appropriately.

A Non-modifiable transaction that is an exclusive access, as indicated by **AxLOCK** asserted, is permitted to have the Size, **AxSIZE**, and Length, **AxLEN**, modified if the total number of bytes accessed remains the same.

There are circumstances where it is not possible to meet the requirements of Non-modifiable transactions. For example, when downsizing to a data width narrower than required by Size, the transaction must be modified.

A component that performs such an operation can optionally include an IMPLEMENTATION DEFINED mechanism to indicate that a modification has occurred. This mechanism can assist with software debug.

### **Modifiable transactions**

A Modifiable transaction can be modified in the following ways:

- A transaction can be broken into multiple transactions.
- Multiple transactions can be merged into a single transaction.
- A read transaction can fetch more data than required.
- A write transaction can access a larger address range than required using the **WSTRB** signals to ensure that only the appropriate locations are updated.
- In each generated transaction, the following attributes can be modified:
  - Address, **AxADDR**
  - Size, **AxSIZE**
  - Length, **AxLEN**
  - Burst type, **AxBURST**

The following must not be changed:

- Exclusive access indicator, **AxLOCK**
- The protection and security attributes, **AxPROT** and **AxNSE**.

**AxCACHE** can be modified, but any modification must ensure that the visibility of transactions by other components is not reduced, either by preventing propagation of transactions to the required point, or by changing the need to look up a transaction in a cache. Any modification to the memory attributes must be consistent for all transactions to the same address range.

The transaction ID and QoS values can be modified.

No transaction modification is permitted that:

- Causes accesses to a different 4KB address space than that of the original transaction.
- Causes a single access to a single-copy atomicity sized region to be performed as multiple accesses. See [A7.1 Single-copy atomicity size](#).

### A5.2.3 Allocate and Other Allocate, **AxCACHE[2]**, and **AxCACHE[3]**

If the Allocate bit is asserted:

- The data might have been previously allocated, so the line must be looked up in a cache.
- It is recommended that the data is allocated into a cache for future use.

If the Other Allocate bit is asserted:

- The data might have been previously allocated, so the line must be looked up in a cache.
- It is not recommended that the data is allocated as it is not expected to be accessed again.

If Allocate and Other Allocate are both deasserted, the request is not required to look up in any cache.

## A5.3 Memory types

The combination of **AxCACHE** signals indicates a memory type. [Table A5.4](#) shows the memory type encodings. Values in brackets are permitted but not preferred. Values that are not shown in the table are reserved.

**Table A5.4: Memory type encoding**

ARCACHE[3:0]	AWCACHE[3:0]	Memory type
0b0000	0b0000	Device Non-bufferable
0b0001	0b0001	Device Bufferable
0b0010	0b0010	Normal Non-cacheable Non-bufferable
0b0011	0b0011	Normal Non-cacheable Bufferable
0b1010	0b0110	Write-Through No-Allocate
0b1110 (0b0110)	0b0110	Write-Through Read-Allocate
0b1010	0b1110 (0b1010)	Write-Through Write-Allocate
0b1110	0b1110	Write-Through Read and Write-Allocate
0b1011	0b0111	Write-Back No-Allocate
0b1111 (0b0111)	0b0111	Write-Back Read-Allocate
0b1011	0b1111 (0b1011)	Write-Back Write-Allocate
0b1111	0b1111	Write-Back Read and Write-Allocate

### A5.3.1 Memory type requirements

This section specifies the required behavior for each of the memory types.

#### **Device Non-bufferable**

The required behavior for Device Non-bufferable memory is:

- The write response must be obtained from the final destination.
- Read data must be obtained from the final destination.
- Transactions are Non-modifiable, see [A5.2.2 Non-modifiable transactions](#).
- Read data must not be prefetched.
- Write transactions must not be merged.

#### **Device Bufferable**

The required behavior for the Device Bufferable memory type is:

- The write response can be obtained from an intermediate point.
- Write transactions must be made visible at the final destination *in a timely manner*.
- Read data must be obtained from the final destination.
- Transactions are Non-modifiable, see [A5.2.2 Non-modifiable transactions](#).

- Read data must not be prefetched.
- Write transactions must not be merged.

Both Device memory types are Non-modifiable. In this specification, the terms Device memory and Non-modifiable memory are interchangeable.

For read transactions, there is no difference in the required behavior for Device Non-bufferable and Device Bufferable memory types.

#### **Normal Non-cacheable Non-bufferable**

The required behavior for the Normal Non-cacheable Non-bufferable memory type is:

- The write response must be obtained from the final destination.
- Read data must be obtained from the final destination.
- Transactions are Modifiable, see [A5.2.2 Modifiable transactions](#).
- Write transactions can be merged.

#### **Normal Non-cacheable Bufferable**

The required behavior for the Normal Non-cacheable Bufferable memory type is:

- The write response can be obtained from an intermediate point.
- Write transactions must be made visible at the final destination *in a timely manner*, as defined in the glossary. There is no mechanism to determine when a write transaction is visible at its final destination.
- Read data must be obtained from either:
  - The final destination.
  - A write transaction that is progressing to its final destination.
- If read data is obtained from a write transaction:
  - It must be obtained from the most recent version of the write.
  - The data must not be cached to service a later read.
- Transactions are Modifiable, see [A5.2.2 Modifiable transactions](#).
- Write transactions can be merged.

For a Normal Non-cacheable Bufferable read, data can be obtained from a write transaction that is still progressing to its final destination. This data is indistinguishable from the read and write transactions propagating to arrive at the final destination at the same time. Read data that is returned in this manner does not indicate that the write transaction is visible at the final destination.

#### **Write-Through No-Allocate**

The required behavior for the Write-Through No-Allocate memory type is:

- The write response can be obtained from an intermediate point.
- Write transactions must be made visible at the final destination *in a timely manner*, as defined in the glossary. There is no mechanism to determine when a write transaction is visible at the final destination.
- Read data can be obtained from an intermediate cached copy.
- Transactions are Modifiable, see [A5.2.2 Modifiable transactions](#).
- Read data can be prefetched.

- Write transactions can be merged.
- A cache lookup is required for read and write transactions.
- The No-Allocate attribute is an allocation hint, that is, it is a recommendation to the memory system that for performance reasons, these transactions are not allocated. However, the allocation of read and write transactions is not prohibited.

#### **Write-Through Read-Allocate**

The required behavior for the Write-Through Read-Allocate memory type is the same as for Write-Through No-Allocate memory. For performance reasons:

- Allocation of read transactions is recommended.
- Allocation of write transactions is not recommended.

#### **Write-Through Write-Allocate**

The required behavior for the Write-Through Write-Allocate memory type is the same as for Write-Through No-Allocate memory. For performance reasons:

- Allocation of read transactions is not recommended.
- Allocation of write transactions is recommended.

#### **Write-Through Read and Write-Allocate**

The required behavior for the Write-Through Read and Write-Allocate memory type is the same as for Write-Through No-Allocate memory. For performance reasons:

- Allocation of read transactions is recommended.
- Allocation of write transactions is recommended.

#### **Write-Back No-Allocate**

The required behavior for the Write-Back No-Allocate memory type is:

- The write response can be obtained from an intermediate point.
- Write transactions are not required to be made visible at the final destination.
- Read data can be obtained from an intermediate cached copy.
- Transactions are Modifiable, see [A5.2.2 Modifiable transactions](#).
- Read data can be prefetched.
- Write transactions can be merged.
- A cache lookup is required for read and write transactions.
- The No-Allocate attribute is an allocation hint, that is, it is a recommendation to the memory system that for performance reasons, these transactions are not allocated. However, the allocation of read and write transactions is not prohibited.

#### **Write-Back Read-Allocate**

The required behavior for the Write-Back Read-Allocate memory type is the same as for Write-Back No-Allocate memory. For performance reasons:

- Allocation of read transactions is recommended.
- Allocation of write transactions is not recommended.

### **Write-Back Write-Allocate**

The required behavior for the Write-Back Write-Allocate memory type is the same as for Write-Back No-Allocate memory. For performance reasons:

- Allocation of read transactions is not recommended.
- Allocation of write transactions is recommended.

### **Write-Back Read and Write-Allocate**

The required behavior for the Write-Back Read and Write-Allocate memory type is the same as for Write-Back No-Allocate memory. For performance reasons:

- Allocation of read transactions is recommended.
- Allocation of write transactions is recommended.

## **A5.3.2 Mismatched memory attributes**

Multiple agents that are accessing the same area of memory, can use mismatched memory attributes. However, for functional correctness, the following rules must be obeyed:

- All Managers accessing the same area of memory must have a consistent view of the cacheability of that area of memory at any level of hierarchy. The rules to be applied are:
  - If the address region is Non-cacheable, all Managers must use transactions with both **AxCACHE[3:2]** deasserted.
  - If the address region is Cacheable, all Managers must use transactions with either of **AxCACHE[3:2]** asserted.
- Different Managers can use different allocation hints.
- If an addressed region is Normal Non-cacheable, any Manager can access it using a Device memory transaction.
- If an addressed region has the Bufferable attribute, any Manager can access it using transactions that do not permit Bufferable behavior. For example, a transaction that requires the response from the final destination does not permit Bufferable behavior.

## **A5.3.3 Changing memory attributes**

The attributes for a particular memory region can be changed from one type to another incompatible type. For example, the attribute can be changed from Write-Through Cacheable to Normal Non-cacheable. This change requires a suitable process to perform the change.

Typically, the following process is performed:

1. All Managers stop accessing the region.
2. A single Manager performs any required cache maintenance operations.
3. All Managers restart accessing the memory region, using the new attributes.

## **A5.3.4 Transaction buffering**

Write access to the following memory types do not require a transaction response from the final destination, but do require that write transactions are made visible at the final destination *in a timely manner*:

- Device Bufferable
- Normal Non-cacheable Bufferable
- Write-Through

For write transactions, all three memory types require the same behavior.

For read transactions, the required behavior is as follows:

- For Device Bufferable memory, read data must be obtained from the final destination.
- For Normal Non-cacheable Bufferable memory, read data must be obtained either from the final destination or from a write transaction that is progressing to its final destination.
- For Write-Through memory, read data can be obtained from an intermediate cached copy.

In addition to ensuring that write transactions progress towards their final destination *in a timely manner*, intermediate buffers must behave as follows:

- An intermediate buffer that can respond to a transaction must ensure that over time, any read transaction to Normal Non-cacheable Bufferable propagates towards its destination. This propagation means that when forwarding a read transaction, the attempted forwarding must not continue indefinitely, and any data that is used for forwarding must not persist indefinitely. The protocol does not define any mechanism for determining how long data that is used for forwarding a read transaction, can persist. However, in such a mechanism, the act of reading the data must not reset the data timeout period.

Without this requirement, continued polling of the same location can prevent the timeout of a read that is held in the buffer, preventing the read progressing towards its destination.

- An intermediate buffer that can hold and merge write transactions must ensure that transactions do not remain in its buffer indefinitely. For example, merging write transactions must not reset the mechanism that determines when a write is drained towards its final destination.

Without this requirement, continued writes to the same location can prevent the timeout of a write held in the buffer, preventing the write progressing towards its destination.

For information about the required behavior of read accesses to these memory types, see:

- [A5.3.1 Device Bufferable](#)
- [A5.3.1 Normal Non-cacheable Bufferable](#)
- [A5.3.1 Write-Through No-Allocate](#)

### A5.3.5 Example use of Device memory types

The specification supports the combined use of Device Non-bufferable and Device Bufferable memory types to force write transactions to reach their final destination and ensure that the issuing Manager knows when the transaction is visible to all other Managers.

A write transaction that is marked as Device Bufferable is required to reach its final destination *in a timely manner*. However, the write response for the transaction can be signaled by an intermediate buffer. Therefore, the issuing Manager cannot know when the write is visible to all other Managers.

If a Manager issues a Device Bufferable write transaction, or stream of write transactions, followed by a Device Non-bufferable write transaction, and all transactions use the same AXI ID, then the AXI ordering requirements force all of the Device Bufferable write transactions to reach the final destination before a response is given to the Device Non-bufferable transaction. Therefore, the response to the Device Non-bufferable transaction indicates that all the transactions are visible to all Managers.

A Device Non-bufferable transaction can only guarantee the completion of Device Bufferable transactions that are issued with the same ID, and are to the same Subordinate device.



## A5.4 Protocol errors

The AXI protocol defines two categories of protocol errors, a software protocol error and a hardware protocol error.

### A5.4.1 Software protocol error

A software protocol error occurs when multiple accesses to the same location are made with mismatched shareability or cacheability attributes. A software protocol error can cause a loss of coherency and result in the corruption of data values. The protocol requires that the system does not deadlock for a software protocol error, and that transactions always progress through a system.

A software protocol error for an access in one 4KB memory region must not cause data corruption in a different 4KB memory region. For locations held in Normal memory, the use of appropriate software barriers and cache maintenance can be used to return memory locations to a defined state.

When accessing a peripheral device, if Modifiable transactions are used (**AxCACHE[1]** is asserted), then the correct operation of the peripheral cannot be guaranteed. The only requirement is that the peripheral continues to respond to transactions in a protocol-compliant manner. The sequence of events that might be needed to return a peripheral device that has been accessed incorrectly, to a known working state is IMPLEMENTATION DEFINED.

### A5.4.2 Hardware protocol error

A hardware protocol error is defined as any protocol error that is not a software protocol error. No support is required for hardware protocol errors.

If a hardware protocol error occurs, then recovery from the error is not guaranteed. The system might crash, lock up, or suffer some other non-recoverable failure.

## A5.5 Memory protection and the Realm Management Extension

AXI provides signals that can be used to protect memory against unexpected transactions.

Memory protection can also be extended using the Realm Management Extension (RME). This provides hardware-based isolation that allows execution contexts to run in different Security states and share resources in the system.

When RME is used, it extends the address spaces for physically addressed and [untranslated transactions](#), affects the operation of [cache maintenance operations](#) and extends the [MPAM](#) signals.

The protection signals are shown in [Table A5.5](#).

**Table A5.5: Protection signals**

Name	Width	Default	Description
AWPROT, ARPROT	3	-	The Access attributes for a request which can be used to protect memory against unexpected transactions.
AWNSE, ARNSE	1	0b0	Extends the physical address spaces that can be addressed to include Root and Realm.

The property `PROT_Present` is used to determine if the **AxPROT** signals are present on an interface.

A Subordinate that does not use the protection attributes can omit the **AxPROT** inputs from its interface.

**Table A5.6: PROT\_Present property**

PROT_Present	Default	Description
True	Y	AWPROT and ARPROT are present.
False		AWPROT and ARPROT are not present.

When RME is used, the `RME_Support` property is set to True and the **AxNSE** signals are present on an interface.

**Table A5.7: RME\_Support property**

RME_Support	Default	Description
True		RME is supported, all RME signals are present on the interface.
False	Y	RME is not supported. There are no RME signals present on the interface.

The protection attributes are split into three parts.

### **Unprivileged / privileged**

An AXI Manager might support more than one level of operating privilege, and can optionally extend this concept of privilege to memory access.

**AxPROT[0]** identifies an access as unprivileged or privileged:

- 0b0: Unprivileged
- 0b1: Privileged

Some processors support multiple levels of privilege, see the documentation for the selected processor to determine the mapping to AXI privilege levels. The only distinction AXI can provide is between privileged and unprivileged access.

### **Security attribute**

If an AXI Manager supports different security operating states, it can extend this to its memory accesses using the security attribute. Requests with different security attributes can be considered as occupying different address spaces, so the same address can decode to a different location depending on the security attribute.

The **AxPROT[1]** and **AxNSE** signals are used to define the security attribute as shown in [Table A5.8](#).

**Table A5.8: Security attribute**

<b>AxNSE</b>	<b>AxPROT[1]</b>	<b>Security attribute</b>
0	0	Secure
0	1	Non-secure
1	0	Root
1	1	Realm

The **AxNSE** signals are only present when the **RME\_Support** property is True. If **RME\_Support** is False, only Secure and Non-secure address spaces are accessible.

### **Instruction / data**

**AxPROT[2]** indicates that the transaction is an instruction access or a data access.

- 0b0: Data access
- 0b1: Instruction access

The AXI protocol defines this indication as a hint. It is not accurate in all cases, for example, where a transaction contains a mix of instruction and data items. It is recommended that a Manager sets **AxPROT[2]** LOW to indicate a data access unless the access is known to be an instruction access.

## A5.6 Memory Encryption Contexts

*Memory Encryption Contexts* (MEC) is an extension to the *Arm Realm Management Extension* (RME) that allows each Realm to have its own unique encryption context. The MEC extension assigns memory encryption contexts to all memory accesses within the Realm Physical Address Space. All memory transactions are associated with a MECID which is determined by the Security state, translation regime, translation tables and the MEC system registers. The MECID is used by a memory encryption engine as an index into a table of encryption contexts, either keys or tweaks, that contribute to the external memory encryption.

Use of MEC can help protect Realm data in memory, by enabling each set of Realm data to be encrypted in a different way. This means that a malicious agent that has access to the physical memory device and is able to decipher one set of Realm data, cannot use the same decryption method to access other sets of Realm data. Before the *Point of Encryption* (PoE) the data that moves between components is in plaintext form.

Realm management software at R-EL2 controls MECID policy and assignment to Realms.

For more information on MEC, see [3] and [4].

Note that the MEC architecture specification [3] details several implementation options for when a MECID value mismatch occurs. This MEC implementation assumes that Managers and caches do not perform any MECID checks. For example, if a read access associated with a MECID targets a location that has a copy present in a cache and is associated with a different MECID, the read access succeeds as though the MECID values did not mismatch. Additional protection is not needed here as Realm management software at R-EL2 ensures that one context can be prevented from accessing locations that belong to a different context, thus ensuring plaintext leakages do not occur.

### A5.6.1 MEC signaling

The MEC\_Support property determines whether an interface supports Memory Encryption Contexts.

**Table A5.9: MEC\_Support property**

MEC_Support	Default	Description
True		MEC is supported, AxMECID signals are present.
False	Y	MEC is not supported, AxMECID signals are not present.

MEC is an extension of RME, so if the RME\_Support property is False, MEC\_Support must be False.

The following signals are required to support MEC.

**Table A5.10: MECID signals**

Name	Width	Default	Description
AWMECID, ARMECID	MECID_WIDTH	All zeros	RME Memory Encryption Context identifier (MECID).

The parameter MECID\_WIDTH defines the width of the **AxMECID** signals.

**Table A5.11: MECID\_WIDTH property**

Name	Values	Default	Description
MECID_WIDTH	0, 16	0	Width of AWMECID and ARMECID in bits.

The following rules apply to the MECID\_WIDTH property:

- If MECID\_WIDTH is 0, **AWMECID** and **ARMECID** are not present on the interface.
- If MEC\_Support is False, MECID\_WIDTH must be 0.
- If MEC\_Support is True, MECID\_WIDTH must not be 0.

Note that the width of MECID does not indicate how many different values are used by a component. It might be possible to reduce the storage requirements of MECID by using a narrower internal width.

If the MECID bit width differs at the interface between two components, it can be zero-extended or have the most-significant bits truncated, as appropriate. This adjustment will produce correct MEC operation only where the common MECID width is set to be the minimal MECID width supported by any MEC-capable component in the system.

The compatibility between Manager and Subordinate interfaces according to the values of the MEC\_Support property is shown in [Table A5.12](#).

**Table A5.12: MEC\_Support compatibility**

MEC_Support	Subordinate: False	Subordinate: True
Manager: False	Compatible.	Compatible. AxMECID inputs are tied LOW.
Manager: True	Compatible. Downstream memory is not encrypted using MEC.	Compatible.

## A5.6.2 MECID usage

The MECID value range is bounded, dependent on the Physical Address Space being accessed.

**Table A5.13: Possible MECID values in each Physical Address Space**

AxNSE	AxPROT[1]	Physical Address Space	MECID
0b0	0b0	Secure	Must be 0
0b0	0b1	Non-secure	Must be 0
0b1	0b0	Root	Must be 0
0b1	0b1	Realm	Any value

MECID is inapplicable and can take any value for the following request Opcodes:

- CMO

- CleanInvalid
- MakeInvalid
- CleanShared
- CleanSharedPersist
- InvalidateHint
- StashTranslation
- UnstashTranslation

MECID is inapplicable and must be 0 for the following request Opcodes:

- DVM Complete

Components that propagate transactions and support MECID on their Subordinate and Manager interfaces must preserve the MECID on requests where it is applicable. Components that perform address translation might change the MECID.

A cache that stores data which has an associated MECID must also store the MECID and provide it with the data during a write-back.

A CleanInvalidPoPA operation can be used to ensure that a cache line is cleaned and invalidated from all caches upstream of the Point of Encryption. See [A10.9 Cache Maintenance and Realm Management Extension](#) for more information on CleanInvalidPoPA.

## A5.7 Multiple region interfaces

This section describes the use of a region identifier with a request, to support interfaces with multiple address regions within a single interface.

### A5.7.1 Region identifier signaling

The property `REGION_Present` determines whether an interface supports region identifier signaling.

**Table A5.14: REGION\_Present property**

REGION_Present	Default	Description
True	Y	AWREGION and ARREGION are present.
False		AWREGION and ARREGION are not present.

The signals to indicate a region are shown in [Table A5.15](#).

**Table A5.15: Region signals**

Name	Width	Default	Description
AWREGION, ARREGION	4	0x0	A 4-bit region identifier which can be used to identify different address regions.

### A5.7.2 Using the region identifier

The 4-bit region identifier can be used to uniquely identify up to 16 different regions. The region identifier can provide a decode of higher-order address bits. The region identifier must remain constant within any 4K-byte address space.

The use of region identifiers means that a single physical interface on a Subordinate can provide multiple logical interfaces, each with a different location in the system address map. The use of the region identifier means that the Subordinate does not have to support the address decode between the different logical interfaces.

This specification expects an interconnect to produce **AxREGION** signals when performing the address decode function for a single Subordinate that has multiple logical interfaces. If a Subordinate only has a single physical interface in the system address map, the interconnect must use the default **AxREGION** values.

There are several usage models for the region identifier including, but not limited to, the following:

- A peripheral can have its main data path and control registers at different locations in the address map, and be accessed through a single interface without the need for the Subordinate to perform an address decode.
- A Subordinate can exhibit different behaviors in different memory regions. For example, a Subordinate might provide read and write access in one region, but read-only access in another region.

A Subordinate must ensure that the correct protocol signaling and the correct ordering of transactions are maintained. A Subordinate must ensure that it provides the responses to two requests to different regions with the same transaction ID in the correct order.

A Subordinate must also ensure the correct protocol signaling for any values of **AxREGION**. If a Subordinate implements fewer than sixteen regions, then the Subordinate must ensure the correct protocol signaling on any

attempted access to an unsupported region. How this is achieved is IMPLEMENTATION DEFINED. For example, the Subordinate might ensure this by:

- Providing an error response for any transaction that accesses an unsupported region.
- Aliasing supported regions across all unsupported regions, to ensure that a protocol-compliant response is given for all accesses.

The **AxREGION** signals only provide an address decode of the existing address space that can be used by Subordinates to remove the need for an address decode function. The signals do not create new independent address spaces. **AxREGION** must only be present on an interface that is downstream of an address decode function.



## A5.8 QoS signaling

AXI supports Quality of Service (QoS) schemes through the features of:

- [A5.8.1 QoS identifiers](#)
- [A5.8.2 QoS acceptance indicators](#)

### A5.8.1 QoS identifiers

An AXI request has an optional identifier which can be used to distinguish between different traffic streams as shown in [Table A5.16](#).

**Table A5.16: QoS signals**

Name	Width	Default	Description
AWQOS, ARQOS	4	0x0	Quality of Service identifier used to distinguish between different traffic streams.

The QOS\_Present property is used to define whether an interface includes the **AxQOS** signals.

**Table A5.17: QOS\_Present property**

QOS_Present	Default	Description
True	Y	AWQOS and ARQOS are present.
False		AWQOS and ARQOS are not present.

The protocol does not specify the exact use of the QoS identifier. It is recommended to use **AxQOS** as a priority indicator for the associated write or read request, where a higher value indicates a higher priority request.

#### **Using the QoS identifiers**

A Manager can produce its own **AxQOS** values, and if it can produce multiple streams of traffic, it can choose different QoS values for the different streams.

Support for QoS requires a system-level understanding of the QoS scheme in use, and collaboration between all participating components. For this reason, it is recommended that a Manager component includes some programmability that can be used to control the exact QoS values that are used for any given scenario.

If a Manager component does not support a programmable QoS scheme, it can use QoS values that represent the relative priorities of the transactions it generates. These values can then be mapped to alternative system level QoS values if appropriate.

This specification expects that many interconnect component implementations will support programmable registers that can be used to assign QoS values to connected Managers. These values replace the QoS values, either programmed or default, supplied by the Managers.

The default system-level implementation of QoS is that any component with a choice of more than one transaction to process selects the request with the higher QoS value to process first. This selection only occurs when there is no other AXI constraint that requires the requests to be processed in a particular order. This means that the AXI ordering rules take precedence over ordering for QoS purposes.

## A5.8.2 QoS acceptance indicators

The QoS acceptance indicators as shown in [Table A5.18](#) are output signals from a Subordinate interface that indicate the minimum QoS value it will accept without delay.

The signals are synchronous to **ACLK** but are unrelated to any other AXI channel.

**Table A5.18: QoS acceptance signals**

Name	Width	Default	Description
VAWQOSACCEPT	4	0x0	An output from a Subordinate that indicates the QoS value for which it accepts requests from the AW channel.
VARQOSACCEPT	4	0x0	An output from a Subordinate that indicates the QoS value for which it accepts requests from the AR channel.

QoS Accept signaling is intended for Subordinate components that have different resources available for different QoS values, which is typically the case with memory controllers. The Subordinate can indicate that it only accepts requests at a certain QoS value or above when the resources available to lower QoS values are in use.

QoS Accept signaling can be used as an input to a Manager interface that might have several different requests to select from. This permits the Manager interface to only issue requests that are likely to be accepted, which avoids unnecessary blocking of the interface. By preventing the issue of requests that might be stalled for a significant period, the interface remains available for the issue of higher priority requests that might arrive at a later point in time.

In this specification, the term **VAxQOSACCEPT** refers collectively to the **VAWQOSACCEPT** and **VARQOSACCEPT** signals.

The rules and recommendations for the **VAxQOSACCEPT** signals are:

- Any requests with QoS level equal to or higher than **VAxQOSACCEPT** are accepted by the Subordinate.
- Any request with QoS level below **VAxQOSACCEPT** might be stalled for a significant time.

This specification does not define a time period during which the Subordinate is required to accept a request at, or above, the QoS level indicated. However, it is expected that for a given Subordinate there will be a deterministic maximum number of clock cycles taken to accept a transaction, after taking into account implementation aspects such as clock domain crossing ratios.

- It is permitted for a Subordinate interface to accept a request that is below the QoS level indicated by the **VAxQOSACCEPT** signal, but it is expected that the request might be subject to a significant delay.

While it is acceptable for a Subordinate to delay a request that has a lower priority than the QoS acceptance level, it is recommended that such a transaction is not delayed indefinitely.

There are several reasons for a lower-priority transaction to be issued on the interface, for example:

- A delay between a change in the QoS acceptance value and the ability of the component to adapt to that change.
- A requirement to make progress on a transaction that is Head-of-line blocking a higher priority request.
- A requirement to make progress on a transaction for reasons of starvation prevention.

The QoS\_Accept property as shown in [Table A5.19](#) is used to define whether an interface includes the QoS accept indicator signals.

**Table A5.19: QoS\_Accept property**

<b>QoS_Accept</b>	<b>Default</b>	<b>Description</b>
True		The interface includes VAWQOSACCEPT and VARQOSACCEPT signals.
False	Y	The interface does not include VAWQOSACCEPT or VARQOSACCEPT signals.

## Chapter A6

# Transaction identifiers and ordering

This chapter describes transaction identifiers and how they can be used to control the ordering of transactions.

It contains the following sections:

- [A6.1 Transaction identifiers](#)
- [A6.2 Unique ID indicator](#)
- [A6.3 Request ordering](#)
- [A6.4 Interconnect use of transaction identifiers](#)
- [A6.5 Write data and response ordering](#)
- [A6.6 Read data ordering](#)

## A6.1 Transaction identifiers

The AXI protocol includes a transaction identifier (AXI ID). A Manager can use the AXI ID to identify transactions that must be returned in order.

All transactions with a given AXI ID value must remain ordered, but there is no restriction on the ordering of transactions with different ID values. A single physical port can support out-of-order transactions by acting as several logical ports, each handling its transactions in order.

By using AXI IDs, a Manager can issue transactions without waiting for earlier transactions to complete. This can improve system performance because it enables parallel processing of transactions.

### A6.1.1 Transaction ID signals

The read and write request, read data, and write response channels include a transaction ID signal.

**Table A6.1: ID signals**

Name	Width	Default	Description
AWID, BID	ID_W_WIDTH	All zeros	Transaction identifier used for the ordering of write requests and responses.
ARID, RID	ID_R_WIDTH	All zeros	Transaction identifier used for the ordering of read requests, responses, and data.

The ID width properties are described in [Table A6.2](#).

**Table A6.2: ID width properties**

Name	Values	Default	Description
ID_W_WIDTH	0..32	-	ID width on write channels in bits, applies to AWID and BID.
ID_R_WIDTH	0..32	-	ID width on read channels in bits, applies to ARID and RID.

If a width property is zero, the associated signal is not present.

A Manager that does not support reordering of its requests and responses, or has only one outstanding transaction, can omit the ID signals from its interface. An attached Subordinate must have its **AxID** inputs tied LOW.

A Subordinate that does not reorder requests or responses does not need to use ID values.

If a Subordinate does not include ID signals, it cannot be connected to a Manager that does have ID signals, because the Manager requires **BID** and **RID** to be reflected from **AWID** and **ARID**.

## A6.2 Unique ID indicator

The unique ID indicator is an optional flag that indicates when a request on the read or write address channels is using an AXI identifier that is unique for in-flight transactions. A corresponding signal is also on the read and write response channels to indicate that a transaction is using a unique ID.

The unique ID indicator can be used downstream of the AXI Manager to determine when a request needs to be ordered with respect to other requests from that Manager. Requests that do not require ordering might not require tracking in downstream components.

The Unique\_ID\_Support property is used to indicate whether an interface supports unique ID indication.

**Table A6.3: Unique\_ID\_Support property**

Unique_ID_Support	Default	Description
True		Unique ID indicator signals are present on the interface.
False	Y	Unique ID indicator signals are not present on the interface.

When Unique\_ID\_Support is True, the following signals are included on the read request, read data, write request, and write response channels.

**Table A6.4: Unique ID indicator signals**

Name	Width	Default	Description
AWIDUNQ, BIDUNQ, ARIDUNQ, RIDUNQ	1	0b0	If asserted high, the ID for this transfer is unique-in-flight.

The following rules apply to the unique ID indicators:

- When **AWIDUNQ** is asserted, there must be no outstanding write transactions from this Manager with the same **AWID** value.
- A Manager must not issue a write request with the same **AWID** as an outstanding write transaction that had **AWIDUNQ** asserted.
- If **AWIDUNQ** is deasserted for a request, the corresponding **BIDUNQ** signal must be deasserted in a single transfer response or the Completion part of a multi-transfer response.
- If **AWIDUNQ** is asserted for a request, the corresponding **BIDUNQ** signal must be asserted in a single transfer response or the Completion part of a multi-transfer response.
- When **ARIDUNQ** is asserted, there must be no outstanding read transactions from this Manager with the same **ARID** value.
- A Manager must not issue a read request with the same **ARID** as an outstanding read transaction that had **ARIDUNQ** asserted.
- If **ARIDUNQ** is deasserted for a request, the corresponding **RIDUNQ** signal must be deasserted for all response transfers for that transaction.

- If **ARIDUNQ** is asserted for a request, the corresponding **RIDUNQ** signal must be asserted for all response transfers for that transaction.
- For an Atomic transaction that includes read and write responses, additional rules apply:
  - If **AWIDUNQ** is deasserted for an Atomic request, the corresponding **RIDUNQ** signal must be deasserted for all response transfers for that transaction.
  - If **AWIDUNQ** is asserted for an Atomic request, the corresponding **RIDUNQ** signal must be asserted for all response transfers for that transaction.

A transaction is outstanding from the cycle that had **AxVALID** asserted until the cycle when the final response transfer is accepted by the Manager. If an interface includes **BCOMP**, the transaction is considered to be outstanding until a response is received with **BCOMP** asserted.

An Atomic transaction is outstanding until both write and read responses are accepted by the Manager, see [A7.4 Atomic transactions](#).

Some transaction types specify that **AxIDUNQ** is required to be asserted, if present. If not specified, asserting **AxIDUNQ** is optional, even if there are no outstanding transactions using the same ID.

## A6.3 Request ordering

The AXI request ordering model is based on the use of the transaction identifier, which is signaled on **ARID** or **AWID**.

Transaction requests on the same channel, with the same ID and destination are guaranteed to remain in order.

Transaction responses with the same ID are returned in the same order as the requests were issued.

The ordering model does not give any ordering guarantees between:

- Transactions from different Managers
- Read and write transactions
- Transactions with different IDs
- Transactions to different Peripheral regions
- Transactions to different Memory locations

If a Manager requires ordering between transactions that have no ordering guarantee, the Manager must wait to receive a response to the first transaction before issuing the second transaction.

### A6.3.1 Memory locations and Peripheral regions

The address map in AMBA is made up of Memory locations and Peripheral regions.

A Memory location has all of the following properties:

- A read of a byte from a Memory location returns the last value that was written to that byte location.
- A write to a byte of a Memory location updates the value at that location to a new value that is obtained by a subsequent read of that location.
- Reading or writing to a Memory location has no side-effects on any other Memory location.
- Observation guarantees for Memory are given for each location.
- The size of a Memory location is equal to the single-copy atomicity size for that component.

A Peripheral region has all of the following properties:

- A read from an address in a Peripheral region does not necessarily return the last value that was written to that address.
- A write to a byte address in a Peripheral region does not necessarily update the value at that address to a new value that is obtained by subsequent reads.
- Accessing an address within a Peripheral region might have side-effects on other addresses within that region.
- Observation guarantees for Peripherals are given per region.
- The size of a Peripheral region is IMPLEMENTATION DEFINED but it must be contained within a single Subordinate component.

A transaction can be to one or more address locations. The locations are determined by **AxADDR** and any relevant qualifiers such as the address space.

- Ordering guarantees are given only between accesses to the same Memory location or Peripheral region.
- A transaction to a Peripheral region must be entirely contained within that region.
- A transaction that spans multiple Memory locations has multiple ordering guarantees.



### A6.3.2 Device and Normal requests

Transactions can be either of type Device or Normal.

#### **Device**

A read or write where the request has **AxCACHE[1]** deasserted.

Device transactions can be used to access Peripheral regions or Memory locations.

#### **Normal**

A read or write where the request has **AxCACHE[1]** asserted.

Normal transactions are used to access Memory locations and are not expected to be used to access Peripheral regions.

A Normal access to a Peripheral region must complete in a protocol-compliant manner, but the result is IMPLEMENTATION DEFINED.

### A6.3.3 Observation and completion definitions

For accesses to Peripheral regions, a Device read or write access DRW1 is observed by a Device read or write access DRW2, when DRW1 arrives at the Subordinate component before DRW2.

For accesses to Memory locations, all of the following apply:

- A write W1 is observed by a write W2, if W2 takes effect after W1.
- A read R1 is observed by a write W2, if R1 returns data from a write W3, when W2 is after W3.
- A write W1 is observed by a read R2, if R2 returns data from either W1 or from write W3, when W3 is after W1.

Read R1 or write W1 can be of type Device or Normal.

The definitions of write and read completions are:

#### **Write completion response**

The cycle when the associated **BRESP** handshake is given, when **BVALID**, **BREADY** and **BCOMP** (if present) are asserted.

#### **Read completion response**

The cycle when the last associated **RDATA** handshake is given, when **RVALID**, **RLAST** and **RREADY** are asserted.

### A6.3.4 Manager ordering guarantees

There are three types of ordering model guarantees:

- Observability guarantees before a completion response is received.
- Observability guarantees from a completion response.
- Response ordering guarantees.

### **Observability guarantees before a completion response is received**

All of the following guarantees apply to transactions from the same Manager using the same ID:

- A Device write DW1 is guaranteed to arrive at the destination before Device write DW2, where DW2 is issued after DW1 and to the same Peripheral region.
- A Device read DR1 is guaranteed to arrive at the destination before Device read DR2, where DR2 is issued after DR1 and to the same Peripheral region.
- A write W1 is guaranteed to be observed by a write W2, where W2 is issued after W1 and to the same Memory location.
- A write W1 that has been observed by a read R2 is guaranteed to be observed by a read R3, where R3 is issued after R2 and to the same Memory location.

### **Observability guarantees from a completion response**

The guarantees from a completion response are as follows:

- For a read request, the completion response guarantees that it is observable to a subsequent read or write request from any Manager.
- For a Non-bufferable write request, the completion response guarantees that it is observable to a subsequent read or write request from any Manager.
- For a Bufferable write request, the completion response can be sent from an intermediate point. It does not guarantee that the write has completed at the endpoint but does guarantee observability, depending on the Domain of the request:
  - Non-shareable: observable to the issuing Manager only.
  - Shareable: observable to all other Managers in the Shareable Domain.
  - System: observable to all other Managers.

For more information on Domains, see [A9.3 Cache coherency and Domains](#).

### **Response ordering guarantees**

Transaction responses have all the following ordering guarantees:

- A read R1 is guaranteed to receive a response before the response to a read R2, where R2 is issued from the same Manager after R1 with the same ID.
- A write W1 is guaranteed to receive a response before the response to a write W2, where W2 is issued from the same Manager after W1 with the same ID.

## **A6.3.5 Subordinate ordering requirements**

To meet the Manager ordering guarantees, Subordinate interfaces must meet the following requirements.

### **Peripheral locations**

For Peripheral locations, the execution order of transactions to Peripheral locations is IMPLEMENTATION DEFINED. This execution order is typically expected to match the arrival order but that is not a requirement.

### **Memory locations**

- A write W1 must be ordered before a write W2 with the same ID to the same Memory location, where W2 is received after W1 is received.
- A write W1 must be ordered before a write W2 to the same Memory location, where W2 is received after the completion response for W1 is given.
- A write W1 must be ordered before a read R2 to the same Memory location, where R2 is received after the completion response for W1 is given.
- A read R1 must be ordered before a write W2 to the same Memory location, where W2 is received after the completion response for R1 is given.

### **Response ordering requirements**

- The response to read R1 must be returned before the response to a read R2, where R2 is received after R1 with the same ID.
- The response to write W1 must be returned before the response to a write W2, where W2 is received after W1 with the same ID.

## **A6.3.6 Interconnect ordering requirements**

An interconnect component has the following attributes:

- A request is received on one port and is either issued on a different port or responded to.
- A response is received on one port and is either issued on a different port or consumed.

When the interconnect issues requests or responses, it must adhere to the following requirements:

- A read R1 request must be issued before a read R2 request, where R2 is received after R1, with the same ID and to the same or overlapping locations.
- A write W1 request must be issued before a write W2 request, where W2 is received after W1, with the same ID, to the same or overlapping locations.
- A Device read DR1 request must be issued before a Device read DR2 request, where DR2 is received after DR1, with the same ID and to the same Peripheral region.
- A Device write DW1 request must be issued before a Device write DW2 request, where DW2 is received after DW1, with the same ID and to the same Peripheral region.
- A read R1 response must be issued before a read R2 response, where R2 is received after R1, with the same ID.
- A write W1 response must be issued before a write W2 response, where W2 is received after W1, with the same ID.

When the interconnect is acting as a Subordinate component, it must also adhere to the Subordinate requirements.

Any manipulation of the AXI ID values that are associated with a transaction must ensure that the ordering requirements of the original ID values are maintained.

## **A6.3.7 Response before the endpoint**

To improve system performance, it is possible for an intermediate component to issue a response to some transactions. This action is known as an early response. The intermediate component issuing an early response must ensure that visibility and ordering guarantees are met.

### Early read response

For Normal read transactions, an intermediate component can respond with read data from a local memory if it is up to date with respect to all earlier writes to the same or overlapping address. In this case, the request is not required to propagate beyond the intermediate component.

An intermediate component must observe ID ordering rules, which means a read response can only be sent if all earlier reads with the same ID have already had a response.

### Early write response

For Bufferable write transactions (**AWCACHE[0]** is asserted), an intermediate component can send an early write response for transactions that have no downstream observers. If the intermediate component sends an early write response, the intermediate component can store a local copy of the data, but must propagate the transaction downstream, before discarding that data.

An intermediate component must observe ID ordering rules, which means a write response can only be sent if all earlier writes with the same ID have already had a response.

After sending an early write response, the component must be responsible for ordering and observability of that transaction until the write has been propagated downstream, and a write response is received. During the period between sending the early write response and receiving a response from downstream, the component must ensure that:

- If an early write response was given for a Normal transaction, all subsequent transactions to the same or overlapping Memory locations are ordered after the write that has had an early response.
- If an early write response was given for a Device transaction, then all subsequent transactions to the same Peripheral region are ordered after the write that has had an early response.

When giving an early write response for a Device Bufferable transaction, the intermediate component is expected to propagate the write transaction without dependency on other transactions. The intermediate component cannot wait for another read or write to arrive before propagating a previous Device write.

## A6.3.8 Ordering between requests with different memory types

There are no ordering requirements between Cacheable requests and Device or Non-cacheable Normal requests.

Ordering requirements between Device and Normal Non-cacheable requests depends on the `Device_Normal_Independence` property.

**Table A6.5: Device\_Normal\_Independence property**

Device_Normal_Independence	Default	Description
True		A Device request is permitted to overtake, or be overtaken by, a Normal Non-cacheable request with the same ID to the same location.
False	Y	Device and Normal Non-cacheable requests with the same ID, to the same location must be observed in issue order.

Guidance for connecting Manager and Subordinate interfaces with different values of `Device_Normal_Independence` is shown in [Table A6.6](#).

**Table A6.6: Device\_Normal\_Independence interoperability**

	<b>Subordinate: False</b>	<b>Subordinate: True</b>
<b>Manager: False</b>	Compatible.	Incompatible. The Subordinate might not meet the ordering requirements of the Manager.
<b>Manager: True</b>	Compatible. The Subordinate might enforce stricter ordering than required.	Compatible.

### A6.3.9 Ordered write observation

To improve compatibility with interface protocols that support a different ordering model, a Subordinate interface can give stronger ordering guarantees for write transactions, known as Ordered Write Observation.

The `Ordered_Write_Observation` property is used to define whether an interface has Ordered Write Observation.

**Table A6.7: Ordered\_Write\_Observation property**

<b>Ordered_Write_Observation</b>	<b>Default</b>	<b>Description</b>
True		The interface exhibits Ordered Write Observation.
False	Y	The interface does not exhibit Ordered Write Observation.

An interface that exhibits Ordered Write Observation gives guarantees for write transactions that are not dependent on the destination or address:

- A write W1 is guaranteed to be observed by a write W2, where W2 is issued after W1, from the same Manager, with the same ID.

When using Ordered Write Observation, a Manager can issue multiple write requests without waiting for write responses, and they are observed in issue order. This can result in improved performance when using the Producer-Consumer ordering model.

## A6.4 Interconnect use of transaction identifiers

When a Manager is connected to an interconnect, the interconnect appends additional bits to the **AWID** and **ARID** identifiers that are unique to that Manager port. This has two effects:

- Managers do not have to know what ID values are used by other Managers because the interconnect makes the ID values used by each Manager unique by appending the Manager number to the original identifier.
- The ID identifier at a Subordinate interface is wider than the ID identifier at a Manager interface.

For write responses, the interconnect uses the additional bits of the **BID** identifier to determine which Manager port the write response is destined for. The interconnect removes these bits of the **BID** identifier before passing the **BID** value to the correct Manager port.

For read data, the interconnect uses the additional bits of the **RID** identifier to determine which Manager port the read data is destined for. The interconnect removes these bits of the **RID** identifier before passing the **RID** value to the correct Manager port.

## A6.5 Write data and response ordering

The Subordinate must ensure that the **BID** value of a write response matches the **AWID** value of the request that it is responding to.

A Manager must issue write data in the same order that it issues the transaction requests.

An interconnect that combines write transactions from different Managers must ensure that it forwards the write data in request order. The interleaving of write data transfers from different transactions is not permitted.

The interconnect must ensure that write responses from a sequence of transactions with the same **AWID** value targeting different Subordinates are received by the Manager in request order.

## A6.6 Read data ordering

The Subordinate must ensure that the **RID** value of any returned data matches the **ARID** value of the request that it is responding to.

The interconnect must ensure that read data from a sequence of transactions with the same **ARID** value targeting different Subordinates are received by the Manager in request order.

The read data reordering depth is the maximum number of accepted requests for which a Subordinate might send read data. A Subordinate that sends read data in the same order as the requests were received has a read data reordering depth of one.

The read data reordering depth is a static value that can be specified by the designer of the Subordinate.

There is no mechanism for a Manager to dynamically determine the read data reordering depth of a Subordinate.

### A6.6.1 Read data interleaving

AXI ordering permits read data transfers with different ID values to be interleaved. This applies to all transactions that can have multiple read data transfers, including Atomic transactions.

Some AXI Manager and interconnect components can be more efficiently designed if it is determined at design-time whether the attached Subordinate interface will interleave read data from different transactions.

The property `Read_Interleaving_Disabled` is used to indicate whether an interface supports the interleaving of read data transfers from different transactions.

**Table A6.8: Read\_Interleaving\_Disabled property**

<code>Read_Interleaving_Disabled</code>	Default	Description
True		A Manager interface is not capable of receiving read data that is interleaved. A Subordinate interface is guaranteed not to interleave read data.
False	Y	A Manager interface is capable of receiving read data that is interleaved. A Subordinate interface might interleave data from read transactions with different ARID values.

For some interfaces, this property can be used as a configuration control, for others it is a capability indicator. All Managers that issue transactions with different IDs must be designed to accept interleaved data. Managers might use the configuration option to disable interleaving as an optimization when the attached Subordinate supports the disabling of interleaving.



## A6.6.2 Read data chunking

The read data chunking option enables a Subordinate interface to reorder read data within a transaction using a 128b granule. The start address might be used as a hint to determine which chunk to send first, but the Subordinate is permitted to return chunks of data in any order.

The property `Read_Data_Chunking` is used to indicate whether an interface supports the return of read data in reorderable chunks.

**Table A6.9: Read\_Data\_Chunking property**

<code>Read_Data_Chunking</code>	Default	Description
True		Read data chunking is supported.
False	Y	Read data chunking is not supported, no chunking signals are present.

### A6.6.2.1 Read data chunking signaling

When read data chunking is supported, the following signals as shown in [Table A6.10](#) are added to the read request and data channel.

**Table A6.10: Read data chunking signals**

Name	Width	Default	Description
ARCHUNKEN	1	0b0	If asserted in a read request, the Subordinate can send read data in 128b chunks.
RCHUNKV	1	0b0	Asserted high to indicate that RCHUNKNUM and RCHUNKSTRB are valid. It must be the same for every response of the transaction.
RCHUNKNUM	RCHUNKNUM_WIDTH	All zeros	Indicates the chunk number being transferred. Chunks are numbered incrementally from zero, according to the data width and base address of the transaction.
RCHUNKSTRB	RCHUNKSTRB_WIDTH	All ones	Indicates the read data chunks that are valid for this transfer. Each bit corresponds to 128 bits of data. The least significant bit of RCHUNKSTRB corresponds to the least significant 128 bits of RDATA.

The **RCHUNKNUM\_WIDTH** property defines the width of the **RCHUNKNUM** signal.

**Table A6.11: RCHUNKNUM\_WIDTH property**

Name	Values	Default	Description
RCHUNKNUM_WIDTH	0, 1, 5, 6, 7, 8	0	Width of RCHUNKNUM in bits. Must be 0 if Read_Data_Chunking == False else 0 or 1 if DATA_WIDTH < 128 8 if DATA_WIDTH == 128 7 if DATA_WIDTH == 256 6 if DATA_WIDTH == 512 5 if DATA_WIDTH == 1024

The **RCHUNKSTRB\_WIDTH** property defines the width of the **RCHUNKSTRB** signal.

**Table A6.12: RCHUNKSTRB\_WIDTH property**

Name	Values	Default	Description
RCHUNKSTRB_WIDTH	0, 1, 2, 4, 8	0	Width of RCHUNKSTRB in bits. Must be 0 if Read_Data_Chunking == False else 0 or 1 if DATA_WIDTH < 256 2 if DATA_WIDTH == 256 4 if DATA_WIDTH == 512 8 if DATA_WIDTH == 1024

Interfaces with a small **DATA\_WIDTH** can include **RCHUNKNUM** and **RCHUNKSTRB** signals as 1-bit wide or omit them from the interface. When using interface protection, the **RCHUNKCHK** signal covers both of these signals, so **RCHUNKNUM** and **RCHUNKSTRB** must be the same width for connected components.

It is recommended that **RCHUNKNUM** and **RCHUNKSTRB** are omitted if not required by the interface.

### A6.6.2.2 Read data chunking protocol rules

In the read data chunking protocol, all the following rules apply:

- **ARCHUNKEN** must only be asserted for transactions with the following attributes:
  - Size is equal to the data channel width, or Length is one transfer.
  - Size is 128 bits or larger.
  - Addr is aligned to 16 bytes.
  - Burst is INCR or WRAP.
  - Opcode is ReadNoSnoop, ReadOnce, ReadOnceCleanInvalid, or ReadOnceMakeInvalid.
- The ID value must be unique-in-flight, which means:
  - **ARCHUNKEN** can only be asserted if there are no outstanding read transactions using the same **ARID** value.
  - The Manager must not issue a request on the read channel with the same **ARID** as an outstanding request that had **ARCHUNKEN** asserted.
  - If present on the interface, **ARIDUNQ** must be asserted if **ARCHUNKEN** is asserted.

- If **ARCHUNKEN** is deasserted, **RCHUNKV** must be deasserted for all response transfers of the transaction.
- If **ARCHUNKEN** is asserted, **RCHUNKV** can be asserted for response transfers of the transaction.
- **RCHUNKV** must be the same for every response transfer of a transaction.
- When **RVALID** and **RCHUNKV** are asserted, **RCHUNKNUM** must be between zero and **ARLEN**.
- When **RVALID** and **RCHUNKV** are asserted, **RCHUNKSTRB** must not be zero.
- When **RVALID** and **RCHUNKV** are asserted, **RLAST** must only be asserted for the final response transfer of the transaction, irrespective of **RCHUNKNUM** and **RCHUNKSTRB**.
- When **RVALID** is asserted and **RCHUNKV** is deasserted, **RCHUNKNUM** and **RCHUNKSTRB** can take any value.

The number of data chunks transferred must be consistent with **ARLEN** and **ARSIZE**, so the number of bytes transferred in a transaction is the same whether chunking is enabled or not. Note that when using read data chunking, a transaction might have more read data transfers than indicated by **ARLEN**.

For unaligned transactions, chunks at addresses lower than **ARADDR** are not transferred and must have **RCHUNKSTRB** deasserted.

### A6.6.2.3 Interoperability

If a Manager supports read data chunking, then downstream interconnect and Subordinates can reduce their buffering if they also support chunking. An interconnect which connects to components with a mixture of chunking support can drive **ARCHUNKEN** and **RCHUNKV** according to the capabilities of the attached components.

When connecting interfaces with different values for the Read\_Data\_Chunking property, the following rules apply as shown in [Table A6.13](#).

**Table A6.13: Read\_Data\_Chunking interoperability**

	Subordinate: False	Subordinate: True
	<b>ARCHUNKEN</b> is not present.	Subordinate <b>ARCHUNKEN</b> input is tied low.
<b>Manager: False</b>	<b>RCHUNKV</b> is not present.	Subordinate <b>RCHUNKV</b> output is unconnected.
	<b>RCHUNKNUM</b> is not present.	Subordinate <b>RCHUNKNUM</b> output is unconnected.
	<b>RCHUNKSTRB</b> is not present.	Subordinate <b>RCHUNKSTRB</b> output is unconnected.
	Full data transfers are sent in natural order.	Full data transfers are sent in natural order.
	Manager <b>ARCHUNKEN</b> output is unconnected.	Chunking signals are connected.
<b>Manager: True</b>	Manager <b>RCHUNKV</b> input is tied low.	Read data can be reordered and sent in chunks.
	Manager <b>RCHUNKNUM</b> input is tied.	
	Manager <b>RCHUNKSTRB</b> input is tied.	
	Full data transfers are sent in natural order.	

### A6.6.2.4 Chunking examples

In these examples, each row in the figure represents a transfer and the shaded cells indicate bytes that are not transferred.

Figure A6.1 shows a transaction on a 256-bit width read data channel where:

- Addr is 0x00.
- Length is 2 transfers.
- Size is 256 bits.
- Burst is INCR.

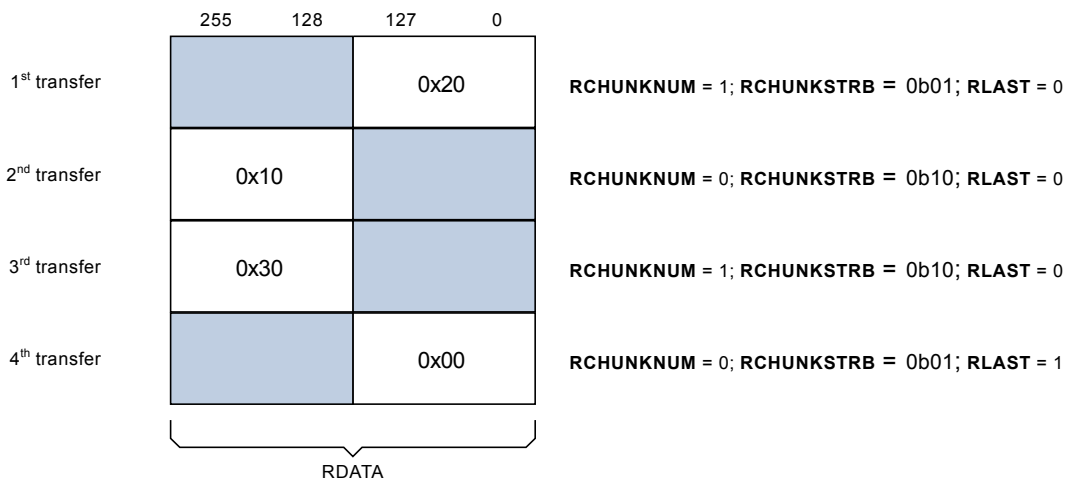

Figure A6.1: Example of read data returned in 128-bit chunks

Figure A6.2 shows a transaction on a 256-bit width read data channel, where:

- Addr is 0x10.
- Length is 2 transfers.
- Size is 256 bits.
- Burst is INCR.

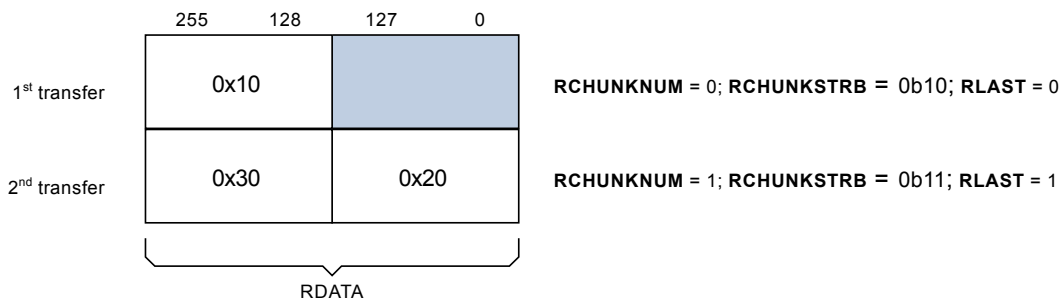

Figure A6.2: Example with an unaligned address and a mixture of 128-bit and 256-bit chunks

Figure A6.3 shows a transaction on a 128-bit width read data channel, where:

- Addr is 0x10.
- Length is 4 transfers.
- Size is 128 bits.
- Burst is WRAP.

- **RCHUNKSTRB** is not present.

The Subordinate uses the start address as a hint and sends the chunk at 0x10 first.

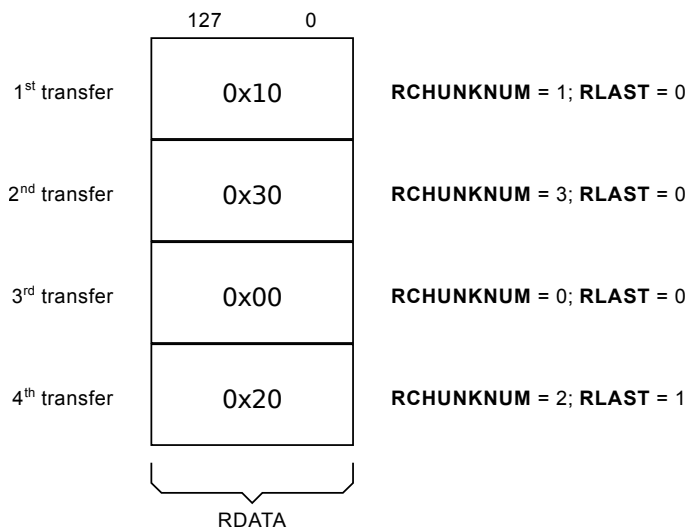

Figure A6.3: Example of a wrapping transaction

## Chapter A7

# Atomic accesses

This chapter describes single-copy and multi-copy atomicity and how to perform exclusive accesses and atomic transactions.

It contains the following sections:

- [A7.1 Single-copy atomicity size](#)
- [A7.2 Multi-copy write atomicity](#)
- [A7.3 Exclusive accesses](#)
- [A7.4 Atomic transactions](#)

## A7.1 Single-copy atomicity size

The single-copy atomicity size is the minimum number of bytes that a transaction updates atomically. The AXI protocol requires a transaction that is larger than the single-copy atomicity size to update memory in blocks of at least the single-copy atomicity size.

Atomicity does not define the exact instant when the data is updated. What must be ensured is that no Manager can ever observe a partially updated form of the atomic data. For example, in many systems, data structures such as linked lists are made up of 32-bit atomic elements. An atomic update of one of these elements requires that the entire 32-bit value is updated at the same time. It is not acceptable for any Manager to observe an update of only 16 bits at one time, and then the update of the other 16 bits later.

More complex systems require support for larger atomic elements, in particular 64-bit atomic elements, so that Managers can communicate using data structures that are based on these larger atomic elements.

The single-copy atomicity sizes that are supported in a system are important because all the components involved in a given communication must support the required size of atomic element. If two Managers are communicating through an interconnect and a single Subordinate, then all the components involved must ensure that transactions of the required size are treated atomically.

The AXI protocol does not require a specific single-copy atomicity size and systems can be designed to support different single-copy atomicity sizes.

In AXI the term single-copy atomic group describes a group of components that can communicate at a particular atomicity. For example, [Figure A7.1](#) shows a system in which:

- The CPU, DSP, DRAM controller, DMA controller, peripherals, SRAM memory and associated interconnect, are in a 32-bit single-copy atomic group.
- The CPU, DSP, DRAM controller, and associated interconnect are also in a 64-bit single-copy atomic group.

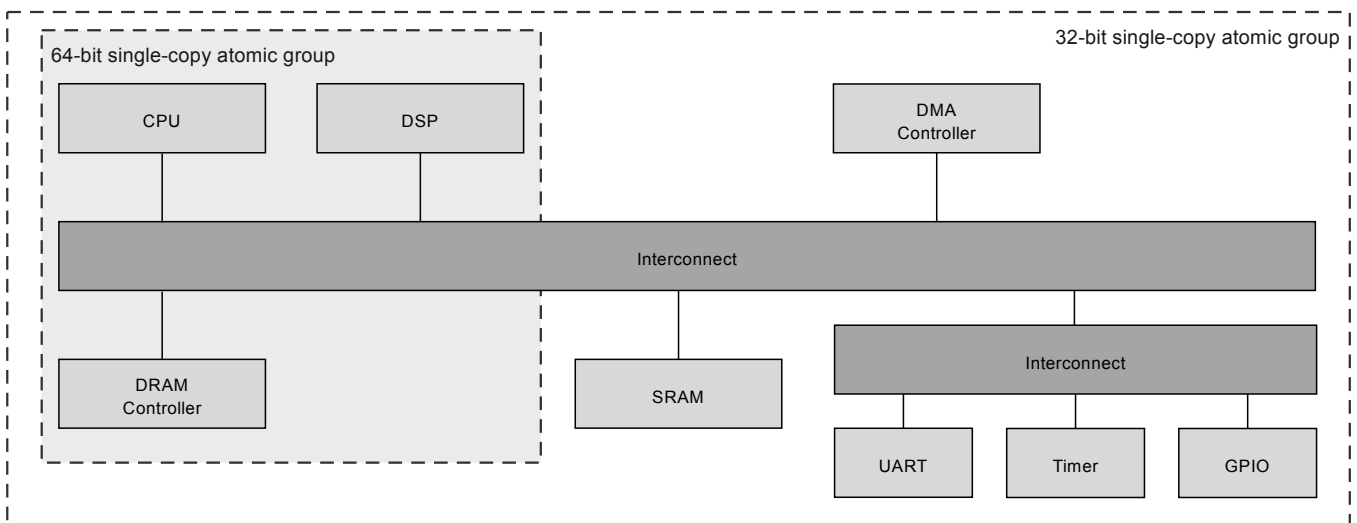

**Figure A7.1: Example system with different single-copy atomic groups**

A transaction never has an atomicity guarantee greater than the alignment of its start address. For example, a transaction in a 64-bit single-copy atomic group that is not aligned to an 8-byte boundary does not have any 64-bit single-copy atomic guarantee.

Byte strobes associated with a transaction do not affect the single-copy atomicity size.

## A7.2 Multi-copy write atomicity

A system is defined as being multi-copy atomic if:

- Writes to the same location are observed in the same order by all agents.
- A write to a location that is observable by an agent, is observable by all agents.

To specify that a system provides multi-copy atomicity, a `Multi_Copy_Atomicity` property is defined.

**Table A7.1: Multi\_Copy\_Atomicity property**

<code>Multi_Copy_Atomicity</code>	Default	Description
True		<code>Multi_Copy_Atomicity</code> is supported.
False	Y	<code>Multi_Copy_Atomicity</code> is not supported.

Multi-copy atomicity can be ensured by:

- Using a single Point of Serialization (PoS) for a given address, so that all accesses to the same location are ordered. This must ensure that all coherent cached copies of a location are invalidated before the new value of the location is made visible to any agents.
- Avoiding the use of forwarding buffers that are upstream of any agents. This prevents a buffered write of a location becoming visible to some agents before it is visible to all agents.

It is required that the `Multi_Copy_Atomicity` property is True for Issue G and later of this specification.



## A7.3 Exclusive accesses

The exclusive access mechanism can provide semaphore-type operations without requiring the connection to remain dedicated to a particular Manager during the operation.

The **AxLOCK** signals are used to indicate an exclusive access, and the **BRESP** and **RRESP** signals indicate the success or failure of the exclusive access write or read respectively.

**Table A7.2: AxLOCK signals**

Name	Width	Default	Description
AWLOCK, ARLOCK	1	0b0	Asserted high to indicate that an exclusive access is required.

The `Exclusive_Accesses` property is used to define whether a Manager issues exclusive accesses or whether a Subordinate supports them:

**Table A7.3: Exclusive\_Accesses property**

Exclusive_Accesses	Default	Description
True	Y	Exclusive accesses are supported. AWLOCK and ARLOCK are present on the interface.
False		Exclusive accesses are not supported. AWLOCK and ARLOCK are not present on the interface.

[Table A7.4](#) provides guidance that applies when connecting Manager and Subordinate components with different property values:

**Table A7.4: Exclusive Accesses Interoperability**

	Subordinate: False	Subordinate: True
Manager: False	Compatible.	Compatible. AWLOCK and ARLOCK are tied LOW.
Manager: True	Not compatible. Exclusive accesses will continually fail, but the interface will not deadlock.	Compatible.

### A7.3.1 Exclusive access sequence

The mechanism of an exclusive access sequence is:

1. A Manager issues an exclusive read request from an address.
2. At some later time, the Manager attempts to complete the exclusive operation by issuing an exclusive write request to the same address, with an **AWID** that matches the **ARID** used for the exclusive read.
3. This exclusive write access is signaled as either:

- Successful, if no other Manager has written to that location since the exclusive read access. In this case, the exclusive write updates memory.
- Failed, if another Manager has written to that location since the exclusive read access. In this case, the memory location is not updated.

A Manager might not complete the write portion of an exclusive operation. The exclusive access monitoring hardware monitors only one address for each transaction ID. If a Manager does not complete the write portion of an exclusive operation, a subsequent exclusive read by that Manager using the same transaction ID changes the address that is being monitored for exclusive accesses.

### A7.3.2 Exclusive access from the perspective of the Manager

A Manager starts an exclusive operation by performing an exclusive read. If the transaction is successful, the Subordinate returns the EXOKAY response, indicating that the Subordinate recorded the address to be monitored for exclusive accesses.

If the Manager attempts an exclusive read from a Subordinate that does not support exclusive accesses, the Subordinate returns the OKAY response instead of the EXOKAY response. In this case, the read data is valid, but the location is not being monitored for exclusivity.

The Manager can treat the OKAY response as an error condition indicating that the exclusive access is not supported. It is recommended that the Manager does not perform the write portion of this exclusive operation.

At some time after the exclusive read, the Manager tries an exclusive write to the same location. If the contents of the addressed location have not been updated since the exclusive read, the exclusive write operation succeeds. The Subordinate returns the EXOKAY response, and updates the memory location.

If the contents of the addressed location have been updated since the exclusive read, the exclusive write attempt fails, and the Subordinate returns the OKAY response instead of the EXOKAY response. The exclusive write attempt does not update the memory location.

A Manager might not complete the write portion of an exclusive operation. If this happens, the Subordinate continues to monitor the address for exclusive accesses until another exclusive read starts a new exclusive access sequence.

A Manager must not start the write part of an exclusive access sequence until the read part is complete.

### A7.3.3 Exclusive access restrictions

The following restrictions apply to exclusive accesses:

- The address of an exclusive access must be aligned to the total number of bytes in the transaction, that is, the product of Size and Length.
- The number of bytes to be transferred in an exclusive access transaction must be a power-of-2, that is, 1, 2, 4, 8, 16, 32, 64, or 128 bytes.
- The maximum number of bytes that can be transferred in an exclusive transaction is 128.
- The Length of an exclusive access must not exceed 16 transfers.
- The Domain must not be Shareable, see [A9.3.3 Shareable Domain](#).
- The Opcode must be ReadNoSnoop or WriteNoSnoop. See [Chapter A8 Request Opcodes](#).
- **AWTAGOP** must not be Match, see [A13.2 Memory Tagging Extension \(MTE\)](#).

Failure to observe these restrictions causes UNPREDICTABLE behavior.

For an exclusive sequence to be successful, the **AxCACHE** values must be appropriate to ensure that the read and write requests reach the exclusive access monitor.

The minimum number of bytes to be monitored during an exclusive operation is the product of Size and Length. The Subordinate can monitor a larger number of bytes, up to 128, which is the maximum number of bytes in an exclusive access. However, this can result in a successful exclusive access being indicated as failing because a neighboring byte was updated.

If any of the signals shown in [Table A7.5](#) are different between the read and write requests in an exclusive sequence, the exclusive write might fail even if the location has not been updated by another agent.

**Table A7.5: Signals that should be the same in an exclusive sequence**

AxID	AxADDR	AxREGION	AxSUBSYSID	AxDOMAIN
AxLEN	AxSIZE	AxBURST	AxLOCK	AxCACHE[1:0]
AxPROT	AxNSE	AxSNOOP	AxMMUATST	AxMMUFLOW
AxMMUVALID	AxMMUSECSID	AxMMUSID	AxMMUSSID	AxMMUSSIDV

#### A7.3.4 Exclusive access from the perspective of the Subordinate

A Subordinate that supports exclusive access must have monitor hardware. It is recommended that such a Subordinate has a monitor unit for each exclusive-capable Manager ID that can access it.

When a Subordinate receives an exclusive read request, it records the address and **ARID** value of any exclusive read operation. Then it monitors that location until either a write occurs to that location or until another exclusive read with the same **ARID** value resets the monitor to a different address.

If the Subordinate can successfully process the exclusive read, it responds with EXOKAY for every read data transfer.

If the Subordinate cannot process the exclusive read, it responds with a response which is not EXOKAY. An exclusive read can have more than one response transfers. It is not permitted to have a mix of OKAY and EXOKAY responses for a single transaction.

When the Subordinate receives an exclusive write with a given **AWID** value, the monitor checks to see if that address is being monitored for exclusive access with that **AWID**. If it is, then this indicates that no write has occurred to that location since the exclusive read access, and the exclusive write proceeds, completing the exclusive access. The Subordinate returns the EXOKAY response to the Manager and updates the addressed memory location.

If the address is not being monitored with the same **AWID** value at the time of an exclusive write, this indicates one of the following:

- The location has been updated since the exclusive read access.
- The monitor has been reset to another location.
- The Manager did not issue an exclusive read with the same attributes as the exclusive write.

In all cases the exclusive write must not update the addressed location, and the Subordinate must return the OKAY response instead of the EXOKAY response.

If a Subordinate that does not support exclusive accesses receives an exclusive write, it responds with an OKAY response and the location is updated.

## A7.4 Atomic transactions

Atomic transactions perform more than just a single access and have an operation that is associated with the transaction. Atomic transactions enable sending the operation to the data, permitting the operation to be performed closer to where the data is located. Atomic transactions are suited to situations where the data is located a significant distance from the agent that must perform the operation.

Compared with using exclusive accesses, this approach reduces the amount of time during which the data must be made inaccessible to other agents in the system.

### A7.4.1 Overview

In an atomic transaction, the Manager sends an address, control information, and outbound data. The Subordinate sends inbound data (except for AtomicStore) and a response. This specification supports four forms of Atomic transaction:

#### **AtomicStore**

- The Manager sends a single data value with an address and the atomic operation to be performed.
- The Subordinate performs the operation using the sent data and value at the addressed location as operands.
- The result is stored in the address location.
- A single response is given without data.
- Outbound data size is 1, 2, 4, or 8 bytes.

#### **AtomicLoad**

- The Manager sends a single data value with an address and the atomic operation to be performed.
- The Subordinate returns the original data value at the addressed location.
- The Subordinate performs the operation using the sent data and value at the addressed location as operands.
- The result is stored in the address location.
- Outbound data size is 1, 2, 4, or 8 bytes.
- Inbound data size is the same as the outbound data size.

#### **AtomicSwap**

- The Manager sends a single data value with an address.
- The Subordinate swaps the value at the addressed location with the data value that is supplied in the transaction.
- The Subordinate returns the original data value at the addressed location.
- Outbound data size is 1, 2, 4, or 8 bytes.
- Inbound data size is the same as the outbound data size.

### AtomicCompare

- The Manager sends two data values, the compare value and the swap value, to the addressed location. The compare and swap values are of equal size.
- The Subordinate checks the data value at the addressed location against the compare value:
  - If the values match, the swap value is written to the addressed location.
  - If the values do not match, the swap value is not written to the addressed location.
- The Subordinate returns the original data value at the addressed location.
- Outbound data size is 2, 4, 8, 16, or 32 bytes.
- Inbound data size is half of the outbound data size because the outbound data contains both compare and swap values, whereas the inbound data has only the original data value.

## A7.4.2 Atomic transaction operations

This specification supports eight different operations that can be used with AtomicStore and AtomicLoad transactions as shown in [Table A7.6](#).

**Table A7.6: Atomic transaction operators**

Operator	Description
ADD	The value in memory is added to the sent data and the result stored in memory.
CLR	Every set bit in the sent data clears the corresponding bit of the data in memory.
EOR	Bitwise exclusive OR of the sent data and value in memory.
SET	Every set bit in the sent data sets the corresponding bit of the data in memory.
SMAX	The value stored in memory is the maximum of the existing value and sent data. This operation assumes signed data.
SMIN	The value stored in memory is the minimum of the existing value and sent data. This operation assumes signed data.
UMAX	The value stored in memory is the maximum of the existing value and sent data. This operation assumes unsigned data.
UMIN	The value stored in memory is the minimum of the existing value and sent data. This operation assumes unsigned data.

## A7.4.3 Atomic transactions attributes

The rules for atomic transactions are as follows:

- **AWLEN** and **AWSIZE** specify the number of bytes of write data in the transaction. For AtomicCompare, the number of bytes must include both the compare and swap values.
- If **AWLEN** indicates a transaction length greater than one, **AWSIZE** is required to be the full data channel width.
- Write strobes that are not within the data window, as specified by **AWADDR** and **AWSIZE**, must be deasserted.
- Write strobes within the data window must be asserted.

**For AtomicStore, AtomicLoad, and AtomicSwap**

- The write data is 1, 2, 4, or 8 bytes and read data is 1, 2, 4, or 8 bytes respectively.
- **AWADDR** must be aligned to the total write data size.
- **AWBURST** must be INCR.

**For AtomicCompare**

- The write data is 2, 4, 8, 16, or 32 bytes and read data is 1, 2, 4, 8, or 16 bytes.
- **AWADDR** must be aligned to half the total write data size.
- If **AWADDR** points to the lower half of the transaction:
  - The compare value is sent first. The compare value is in the lower bytes of a single-transfer transaction, or in the first transfers of a multi-transfer transaction.
  - **AWBURST** must be INCR.
- If **AWADDR** points to the upper half of the transaction:
  - The swap value is sent first. The swap value is in the lower bytes of a single-transfer transaction, or in the first transfers of a multi-transfer transaction.
  - **AWBURST** must be WRAP.
- There are relaxations to the usual rules for transactions of type WRAP:
  - A Length of 1 is permitted.
  - **AWADDR** is not required to be aligned to the transfer size.

Examples of AtomicCompare transactions with a 64-bit data channel are shown in [Figure A7.2](#).

AWADDR	AWSIZE	AWLEN	AWBURST	7	6	5	4	3	2	1	0	
0x00	1 (2B)	0	INCR	-	-	-	-	-	-	S	C	
0x01	1 (2B)	0	WRAP	-	-	-	-	-	-	C	S	
0x04	2 (4B)	0	INCR	S	S	C	C	-	-	-	-	
0x06	2 (4B)	0	WRAP	C	C	S	S	-	-	-	-	
0x00	3 (8B)	0	INCR	S	S	S	S	C	C	C	C	
0x04	3 (8B)	0	WRAP	C	C	C	C	S	S	S	S	
0x00	3 (8B)	1	INCR	C	C	C	C	C	C	C	C	1 <sup>st</sup> Transfer
				S	S	S	S	S	S	S	S	S
0x08	3 (8B)	1	WRAP	S	S	S	S	S	S	S	S	1 <sup>st</sup> Transfer
				C	C	C	C	C	C	C	C	C

Figure A7.2: Examples showing the location of the Compare and Swap values for an AtomicCompare

#### A7.4.4 ID use for Atomic transactions

A single AXI ID is used for an Atomic transaction. The same AXI ID is used for the request, write response, and the read data. This requirement means that the Manager must only use ID values that can be signaled on both **AWID** and **RID** signals.

Atomic transactions must not use AXI ID values that are used by Non-atomic transactions that are outstanding at the same time. This rule applies to transactions on either the AR or AW channel. This rule ensures that there are no ordering constraints between Atomic transactions and Non-atomic transactions.

If one transaction has fully completed before the other is issued, Atomic transactions and Non-atomic transactions can use the same AXI ID value.

Multiple Atomic transactions that are outstanding at the same time must not use the same AXI ID value.

For Atomic transactions that use the read data channel, if the interface includes Unique ID signaling then **RIDUNQ** must be asserted if **AWIDUNQ** was asserted. See [A6.2 Unique ID indicator](#) for more details.

#### A7.4.5 Request attribute restrictions for Atomic transactions

For Atomic transactions, the following restrictions apply for request attributes:

- **AWCACHE** and **AWDOMAIN** are permitted to be any combination valid for the interface type. See [Table A9.7](#).
- **AWSNOOP** must be set to all zeros. If **AWSNOOP** has any other value, **AWATOP** must be all zeros.
- **AWLOCK** must be deasserted, not exclusive access.

### A7.4.6 Atomic transaction signaling

To support Atomic transactions **AWATOP** is added to an interface.

**Table A7.7: ID signals**

Name	Width	Default	Description
AWATOP	6	0x00	Indicates the type and endianness of an atomic transaction.

The encodings for **AWATOP** are shown in [Table A7.8](#) and [Table A7.9](#).

**Table A7.8: AWATOP encodings**

AWATOP[5:0]	Description
0b000000	Non-atomic operation
0b01exxx	AtomicStore
0b10exxx	AtomicLoad
0b110000	AtomicSwap
0b110001	AtomicCompare

For AtomicStore and AtomicLoad transactions **AWATOP[3]** indicates the endianness that is required for the atomic operation:

- When deasserted, this bit indicates that the operation is little-endian.
- When asserted, this bit indicates that the operation is big-endian.

The value of **AWATOP[3]** applies to arithmetic operations only and is ignored for bitwise logical operations.

For AtomicStore and AtomicLoad transactions, [Table A7.9](#) shows the encodings for the operations on the lower-order **AWATOP[2:0]** signals.

**Table A7.9: Lower order AWATOP[2:0] encodings**

AWATOP[2:0]	Operation	Description
0b000	ADD	Add
0b001	CLR	Bit clear
0b010	EOR	Exclusive OR
0b011	SET	Bit set
0b100	SMAX	Signed maximum
0b101	SMIN	Signed minimum
0b110	UMAX	Unsigned maximum
0b111	UMIN	Unsigned minimum



### A7.4.7 Transaction structure

For AtomicLoad, AtomicSwap, and AtomicCompare transactions, the transaction structure is as follows:

- The request is issued on the AW channel.
- The associated transaction data is sent on the W channel.
- The number of write data transfers required on the W channel is determined by the **AWLEN** signal.
- The relative timing of the Atomic transaction request and the Atomic transaction write data is not specified.
- The Subordinate returns the original data value using the R channel.
- The number of read data transfers is determined from both **AWLEN** and the **AWATOP** signals. For the AtomicCompare operation, if **AWLEN** indicates a transaction length greater than 1, then the number of read data transfers is half that specified by **AWLEN**.
- A Subordinate is permitted to wait for all write data before sending read data. A Manager must be able to send all write data without receiving any read data.
- A Subordinate is permitted to send all read data before accepting any write data. A Manager must be able to accept all read data without any write data being accepted.
- A single write response is returned on the B channel. The write response must be given by the Subordinate only after it has received all write data transfers and the result of the atomic transaction is observable.

The transfers involved in AtomicLoad, AtomicSwap, and AtomicCompare transactions are shown in [Figure A7.3](#).

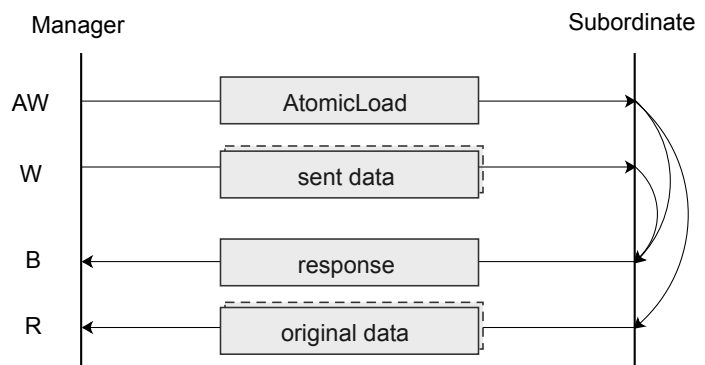

**Figure A7.3: AtomicLoad, AtomicSwap, or AtomicCompare transaction**

For AtomicStore transactions, the transaction structure is as follows:

- The request is issued on the AW channel.
- The associated transaction data is sent on the W channel.
- The number of write data transfers required on the W channel is determined by the **AWLEN** signal.
- The relative timing of the Atomic transaction request and the Atomic transaction write data is not specified.
- A single write response is returned on the B channel. The write response must be given only by the Subordinate after it has received all write data transfers and the result of the atomic transaction is observable.

The transfers involved in AtomicStore transactions are shown in [Figure A7.4](#).

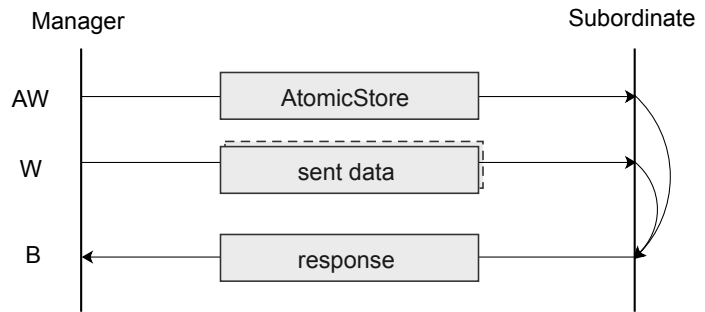

Figure A7.4: AtomicStore transaction

### A7.4.8 Response signaling

The write response to an Atomic transaction indicates that the transaction is visible to all required observers.

Atomic transactions that include a read response are visible to all required observers from the point of receiving the first item of read data.

A Manager is permitted to use either read or write response as indication that a transaction is visible to all required observers.

There is no concept of an error that is associated with the operation, such as overflow. An operation is fully specified for all input combinations.

For transactions, such as AtomicCompare, where there are multiple outcomes for the transaction, no indication is provided on the outcome of the transaction. To determine if a Compare and Swap instruction has updated the memory location, it is necessary to inspect the original data value that is returned as part of the transaction.

It is permitted to give an error response to an Atomic transaction when the transaction reaches a component that does not support Atomic transactions.

For AtomicLoad, AtomicSwap and AtomicCompare transactions:

- A Subordinate must send the correct number of read data transfers, even if the write response is DECERR or SLVERR.
- A Manager might ignore the write response and only use the response that comes with read data.

### A7.4.9 Atomic transaction dependencies

For AtomicLoad, AtomicSwap, and AtomicCompare transactions, [Figure A7.5](#) shows the following Atomic transaction handshake signal dependencies:

- The Manager must not wait for the Subordinate to assert **AWREADY** or **WREADY** before asserting **AWVALID** or **WVALID**.
- The Subordinate can wait for **AWVALID** or **WVALID**, or both, before asserting **AWREADY**.
- The Subordinate can assert **AWREADY** before **AWVALID** or **WVALID**, or both, are asserted.
- The Subordinate can wait for **AWVALID** or **WVALID**, or both, before asserting **WREADY**.
- The Subordinate can assert **WREADY** before **AWVALID** or **WVALID**, or both, are asserted.
- The Subordinate must wait for **AWVALID**, **AWREADY**, **WVALID**, and **WREADY** to be asserted before asserting **BVALID**.
- The Subordinate must also wait for **WLAST** to be asserted before asserting **BVALID** because the write response **BRESP**, must be signaled only after the last data transfer of a write transaction.

- The Subordinate must not wait for the Manager to assert **BREADY** before asserting **BVALID**.
- The Manager can wait for **BVALID** before asserting **BREADY**.
- The Manager can assert **BREADY** before **BVALID** is asserted.
- The Subordinate must wait for both **AWVALID** and **AWREADY** to be asserted before it asserts **RVALID** to indicate that valid data is available.
- The Subordinate must not wait for the Manager to assert **RREADY** before asserting **RVALID**.
- The Manager can wait for **RVALID** to be asserted before it asserts **RREADY**.
- The Manager can assert **RREADY** before **RVALID** is asserted.
- The Manager must not wait for the Subordinate to assert **RVALID** before asserting **WVALID**.
- The Subordinate can wait for **WVALID** to be asserted, for all write data transfers, before it asserts **RVALID**.
- The Manager can assert **WVALID** before **RVALID** is asserted.

In the dependency diagram that [Figure A7.5](#) shows:

- A single-headed arrow points to a signal that can be asserted before or after the signal at the start of the arrow.
- A double-headed arrow points to a signal that must be asserted only after assertion of the signal at the start of the arrow.

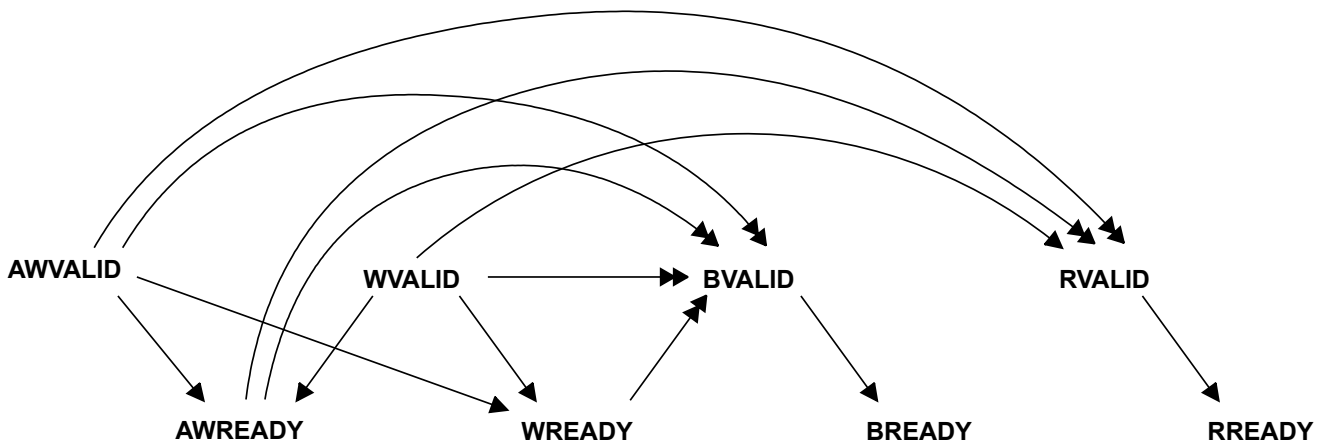

Figure A7.5: Atomic transaction handshake dependencies

### A7.4.10 Support for Atomic transactions

The `Atomic_Transactions` property is used to indicate whether a component supports Atomic transactions.

Table A7.10: `Atomic_Transactions` property

Atomic_Transactions	Default	Description
True		Atomic Transactions are supported.
False	Y	Atomic Transactions are not supported.

In some implementations this will be a fixed interface attribute, other implementations might enable the design-time setting of the property.

If a Subordinate or interconnect component declares that it supports Atomic transactions, then it must support all operation types, sizes, and endianness.

### **Manager support**

A Manager component that supports Atomic transactions can also include a mechanism to suppress the generation of Atomic transactions to ensure compatibility in systems where Atomic transactions are not supported.

An optional **BROADCASTATOMIC** pin is specified. When present and deasserted, Atomic transactions are not issued by the Manager.

**Table A7.11: BROADCASTATOMIC tie-off input**

Name	Width	Default	Description
BROADCASTATOMIC	1	0b1	Manager tie-off input, used to control the issuing of Atomic transactions from an interface.

### **Subordinate support**

It is optional for a Subordinate component to support Atomic transactions.

If a Subordinate component only supports Atomic transactions for particular memory types, or for particular address regions, then the Subordinate must give an appropriate error response for the Atomic transactions that it does not support.

### **Interconnect support**

It is optional for an interconnect to support Atomic transactions.

If an interconnect does not support Atomic transactions, all attached Manager components must be configured to not generate Atomic transactions.

Atomic transactions, can be supported at any point within an interconnect that supports them, including passing Atomic transactions downstream to Subordinate components.

Atomic transactions are not required to be supported for every address location. If Atomic transactions are not supported for a given address location, then an appropriate error response can be given for the transaction. See [A4.3 Transaction response](#).

For Device transactions, the Atomic transaction must be passed to the endpoint Subordinate. If the Subordinate is configured to indicate that it does not support Atomic transactions, then the interconnect must give an error response for the transaction. An Atomic transaction must not be passed to a component that does not support Atomic transactions.

For Cacheable transactions, the interconnect can either:

- Perform the atomic operation within the interconnect. This method requires that the interconnect performs the appropriate read, write, and snoop transactions to complete the operation.
- If the appropriate endpoint Subordinate is configured to indicate that it does support atomic operations, then the interconnect can pass the atomic operation to the Subordinate.

## Chapter A8

# Request Opcodes

The request Opcode indicates the function of a request and how it must be processed by a Subordinate.

This chapter summarizes all Opcodes that are available with links in the tables to detailed descriptions of how they work.

It contains the following sections:

- [A8.1 Opcode signaling](#)
- [A8.2 AWSNOOP encodings](#)
- [A8.3 ARSNOOP encodings](#)

## A8.1 Opcode signaling

The request Opcode is communicated using the **AWSNOOP** and **ARSNOOP** signals.

**Table A8.1: AxSNOOP signals**

Name	Width	Default	Description
AWSNOOP	AWSNOOP_WIDTH	0x00 (WriteNoSnoop / WriteUniquePtl / Atomic)	Opcode for requests using the write channels.
ARSNOOP	ARSNOOP_WIDTH	0x0 (ReadNoSnoop / ReadOnce)	Opcode for requests using the read channels.

WriteNoSnoop, WriteUniquePtl, ReadNoSnoop and ReadOnce are default Opcodes and are used for generic requests.

The **AxSNOOP** width properties are defined in [Table A8.2](#).

**Table A8.2: AxSNOOP width properties**

Name	Values	Default	Description
AWSNOOP_WIDTH	0, 4, 5	4	Width of AWSNOOP in bits.
ARSNOOP_WIDTH	0, 4	4	Width of ARSNOOP in bits.

If any of the following properties are not False, AWSNOOP\_WIDTH must be 5:

- WriteDeferrable\_Transaction
- UnstashTranslation\_Transaction
- InvalidateHint\_Transaction

If any of the following properties are not False, AWSNOOP\_WIDTH must be 4 or 5:

- Shareable\_Cache\_Support
- WriteNoSnoopFull\_Transaction
- CMO\_On\_Write
- WriteZero\_Transaction
- Cache\_Stash\_Transactions
- Untranslated\_Transactions
- Prefetch\_Transaction

If any of the following properties are not False, ARSNOOP\_WIDTH must be 4:

- Shareable\_Cache\_Support
- DeAllocation\_Transactions
- CMO\_On\_Read
- DVM\_Message\_Support

Any **AxSNOOP** bits not driven by an interface are assumed to be LOW.

A Manager that only issues WriteNoSnoop/WriteUniquePtl/Atomic requests can set **AWSNOOP\_WIDTH** to 0 which omits the **AWSNOOP** output from its interface. An attached Subordinate must have its **AWSNOOP** input tied LOW.

A Manager that only issues ReadNoSnoop/ReadOnce requests can set **ARSNOOP\_WIDTH** to 0 which omits the **ARSNOOP** output from its interface. An attached Subordinate must have its **ARSNOOP** input tied LOW.

## A8.2 AWSNOOP encodings

The encodings for **AWSNOOP** are shown in [Table A8.3](#). Some Opcodes depend on the Domain of the request. The Enable column lists the property expression that determines whether a Manager interface is permitted to use the Opcode and a Subordinate interface supports it.

Unlisted combinations of **AWSNOOP** and **AWDOMAIN** are illegal.

**Table A8.3: AWSNOOP encodings**

AWSNOOP	AWDOMAIN <sup>1</sup>	Opcode	Enable	Description
0b00000	NSH, SYS	WriteNoSnoop	-	Write to a Non-shareable or System location.
	SH	WriteUniquePtl	Shareable_Transactions	Write to a Shareable location.
	NSH, SH, SYS	Atomic	Atomic_Transactions	Atomic transaction, indicated by nonzero AWATOP signal.
0b00001	NSH	WriteNoSnoopFull	WriteNoSnoopFull_Transaction or Shareable_Cache_Support	Cache line sized and Regular write to a Non-shareable location.
	SH	WriteUniqueFull	Shareable_Transactions	Cache line sized and Regular write to a Shareable location.
0b00010	-	RESERVED	-	
0b00011	SH	WriteBackFull	Shareable_Transactions and Shareable_Cache_Support	Cache line sized and Regular write to a Shareable location. The line was held in a coherent cache and is Dirty.
0b00100	-	RESERVED	-	
0b00101	SH	WriteEvictFull	Shareable_Transactions and Shareable_Cache_Support	Cache line sized and Regular write to a Shareable location. The line was held in a coherent cache and is Clean.
0b00110	NSH, SH	CMO	CMO_On_Write	A data-less request which indicates that a cache maintenance operation must be performed. The specific operation is encoded on the AWC MO signal. Cache line sized and Regular.
0b00111	NSH, SH, SYS	WriteZero	WriteZero_Transaction	Cache line sized and Regular write, where the value of every byte is zero.
0b01000	SH	WriteUniquePtlStash	Shareable_Transactions and Cache_Stash_Transactions	Write to a Shareable location with an indication that the data should be allocated into a cache. Cache line sized or smaller.

*Continued on next page*



Table A8.3 – Continued from previous page

<b>AWSNOOP</b>	<b>AWDOMAIN<sup>1</sup></b>	<b>Opcode</b>	<b>Enable</b>	<b>Description</b>
0b01001	SH	<a href="#">WriteUniqueFullStash</a>	Shareable_Transactions and Cache_Stash_Transactions	Cache line sized and Regular write to a Shareable location with an indication that the data should be allocated into a cache.
0b01010	NSH, SH	<a href="#">WritePtlCMO</a>	Write_Plus_CMO	Write where any cached copies of the line must be cleaned and/or invalidated according to the AWCMO signal. Cache line sized or smaller.
0b01011	NSH, SH	<a href="#">WriteFullCMO</a>	Write_Plus_CMO	Cache line sized and Regular write where any cached copies of the line must be cleaned and/or invalidated according to the AWCMO signal.
0b01100	NSH, SH	<a href="#">StashOnceShared</a>	Cache_Stash_Transactions	A data-less request which indicates that a cache line should be fetched into a cache. Other copies of the line are not required to be invalidated. Cache line sized and Regular.
0b01101	NSH, SH	<a href="#">StashOnceUnique</a>	Cache_Stash_Transactions	A data-less request which indicates that a cache line should be fetched into a cache. It is recommended that all other copies are invalidated. Cache line sized and Regular.
0b01110	NSH, SH, SYS	<a href="#">StashTranslation</a>	Untranslated_Transactions and Cache_Stash_Transactions	A data-less request which indicates that a translation should be cached in an MMU.
0b01111	NSH, SH	<a href="#">Prefetch</a>	Prefetch_Transaction	A data-less request which indicates that a Manager might read the addressed cache line at a later time. Cache line sized and Regular.
0b10000	SYS	<a href="#">WriteDeferrable</a>	WriteDeferrable_Transaction	A 64-byte atomic write where the Subordinate can give a DEFER or UNSUPPORTED response.
0b10001	NSH, SH, SYS	<a href="#">UnstashTranslation</a>	UnstashTranslation_Transaction	A data-less request which is a hint that a translation is not likely to be used again.

*Continued on next page*

Table A8.3 – Continued from previous page

<b>AWSNOOP</b>	<b>AWDOMAIN<sup>1</sup></b>	<b>Opcode</b>	<b>Enable</b>	<b>Description</b>
0b10010	NSH, SH	<a href="#">InvalidateHint</a>	InvalidateHint_Transaction	A data-less request which indicates that a cache line is no longer required and can be invalidated. A write-back is permitted but not required. Cache line sized and Regular.
0b10011 to 0b11111	-	RESERVED	-	-

<sup>1</sup> NSH is Non-shareable (0b00), SH is Shareable (0b01 or 0b10), SYS is System (0b11).

## A8.3 ARSNOOP encodings

The encodings for **ARSNOOP** are shown in [Table A8.4](#). Some Opcodes depend on the Domain of the request. The Enable column lists the property expression that determines whether a Manager interface is permitted to use the Opcode and a Subordinate interface supports it.

Unlisted combinations of **ARSNOOP** and **ARDOMAIN** are illegal.

**Table A8.4: ARSNOOP encodings**

ARSNOOP	ARDOMAIN <sup>1</sup>	Opcode	Enable	Description
0b0000	NSH, SYS	ReadNoSnoop	-	Read from a Non-shareable or System location.
	SH	ReadOnce	Shareable_Transactions	Read from a Shareable location which the Manager will not cache.
0b0001	SH	<a href="#">ReadShared</a>	Shareable_Transactions and Shareable_Cache_Support	Cache line sized and Regular read from a Shareable location which the Manager might cache. Data can be Dirty.
0b0010	SH	<a href="#">ReadClean</a>	Shareable_Transactions and Shareable_Cache_Support	Cache line sized and Regular read from Shareable location which the Manager might cache. Data must not be Dirty.
0b0011	-	RESERVED	-	-
0b0100	SH	<a href="#">ReadOnceCleanInvalid</a>	Shareable_Transactions and DeAllocation_Transactions	Read from a Shareable location which the Manager will not cache. Cached copies are recommended to be cleaned and invalidated. Cache line sized or smaller.
0b0101	SH	<a href="#">ReadOnceMakeInvalid</a>	Shareable_Transactions and DeAllocation_Transactions	Read from a Shareable location which the Manager will not cache. Cached copies are recommended to be invalidated without a write-back. Cache line sized or smaller.
0b0110	-	RESERVED	-	-
0b0111	-	RESERVED	-	-
0b1000	NSH, SH	<a href="#">CleanShared</a>	CMO_On_Read	A request to clean all copies of a cache line. Cache line sized and Regular.
0b1001	NSH, SH	<a href="#">CleanInvalid</a>	CMO_On_Read	A request to clean and invalidate all copies of a cache line. Cache line sized and Regular.

*Continued on next page*

Table A8.4 – Continued from previous page

ARSNOOP	ARDOMAIN <sup>1</sup>	Opcode	Enable	Description
0b1010	NSH, SH	CleanSharedPersist	CMO_On_Read and Persist_CMO	A request to clean all copies of a cache line. Cleaned data must pass the Point of Persistence or Point of Deep Persistence. Cache line sized and Regular.
0b1011	-	RESERVED	-	-
0b1100	-	RESERVED	-	-
0b1101	NSH, SH	MakeInvalid	CMO_On_Read	A request to clean and invalidate all copies of a cache line. Dirty data is not required to be written to memory. Cache line sized and Regular.
0b1110	SH	DVM Complete	DVM_Message_Support	Indicates completion of a DVM synchronization message.
0b1111	-	RESERVED	-	-

<sup>1</sup> NSH is Non-shareable (0b00), SH is Shareable (0b01 or 0b10), SYS is System (0b11).

## Chapter A9

# Caches

This chapter describes caching in the AXI protocol.

It contains the following sections:

- [A9.1 Caching in AXI](#)
- [A9.2 Cache line size](#)
- [A9.3 Cache coherency and Domains](#)
- [A9.4 I/O coherency](#)
- [A9.5 Caching Shareable lines](#)
- [A9.6 Prefetch transaction](#)
- [A9.7 Cache Stashing](#)
- [A9.8 Deallocating read transactions](#)
- [A9.9 Invalidate hint](#)

## A9.1 Caching in AXI

In this specification, the term *cache* is used for any storage structure, including caches, buffers, or other intermediate storage elements. Data can be cached at various points in a system. An example topology is shown in Figure A9.1. In the example, there is a system cache which is visible to all agents, local Shareable caches which are visible to all coherent agents and local Non-shareable caches which are visible to a single agent.

Fully coherent agents use hardware coherency with data snooping to keep their caches coherent. These will typically use an AMBA CHI interface [5].

I/O coherent agents can share data with fully coherent agents but any data that is cached locally to them must be manually maintained to ensure coherency.

Non-coherent agents must use manual cache maintenance on any data that is shared with other agents and cached locally.

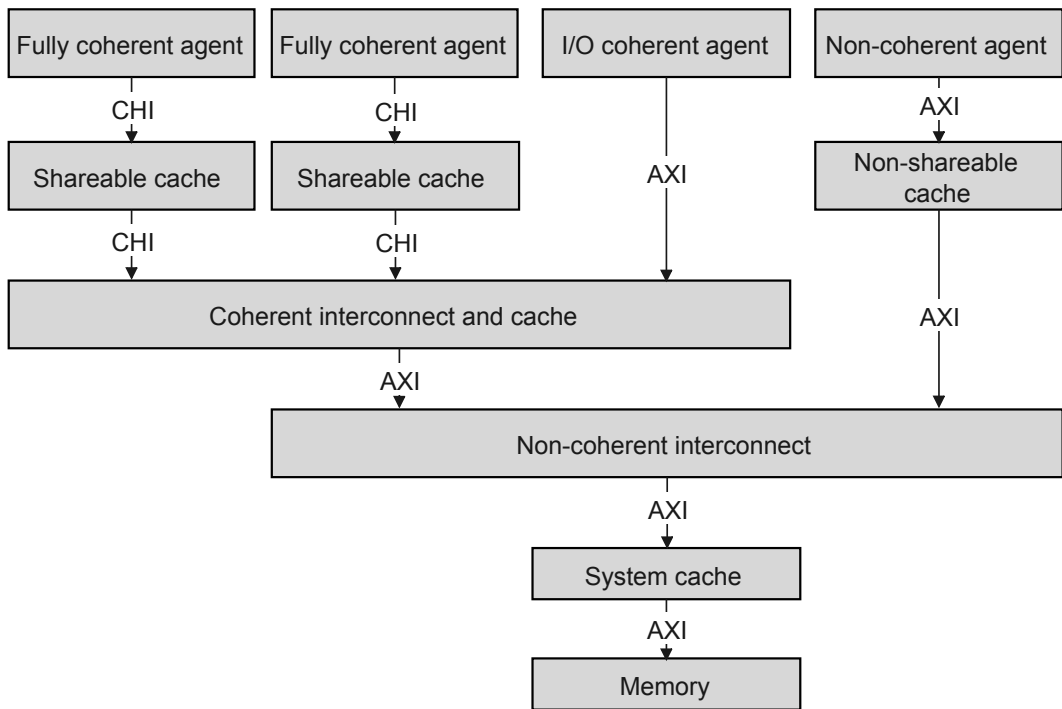

Figure A9.1: Example system topology showing possible cache locations and type

## A9.2 Cache line size

A cache line is defined as a cached copy of sequentially byte addressed memory locations, with the first address aligned to the total size of the cache line. A system which employs cache sharing must have a common cache line size. Some transactions only operate on entire cache lines and must be cache line sized.

The cache line size is fixed at design time and defined using the `Cache_Line_Size` property.

Name	Values	Default	Description
<code>Cache_Line_Size</code>	16, 32, 64, 128, 256, 512, 1024, 2048	64	Cache line size in bytes.

For any interfaces carrying cache line sized transactions, the data width must be wide enough to transport a cache line using 16 transfers or fewer.

To be compatible with AMBA CHI, cache line size must be 64 bytes.

Opcodes where the transaction must be cache line sized and Regular are shown in [Table A9.2](#). For more information on Regular transactions, see [A4.1.8 Regular transactions](#).

**Table A9.2: Opcodes which must be cache line sized and Regular**

Transactions on the read channels	Transactions on the write channels
ReadShared	WriteNoSnoopFull
ReadClean	WriteUniqueFull
CleanShared	WriteBackFull
CleanInvalid	WriteEvictFull
MakeInvalid	CMO
CleanSharedPersist	WriteZero
	WriteUniqueFullStash
	WriteFullCMO
	StashOnceShared
	StashOnceUnique
	Prefetch
	InvalidateHint

Cache line sized, Regular transactions have the following constraints:

- Size x Length must be equal to the cache line size.
- Length can be 1, 2, 4, 8 or 16.
- If Length is greater than 1, Size must be equal to the data channel width.
- Burst must not be FIXED.
- If Burst is INCR, Address must be aligned to the cache line size.
- If Burst is WRAP, Address must be aligned to Size.
- The request must be Modifiable, that is **AxCACHE[1]** is asserted.

- The request must not be an exclusive access, that is **AxLOCK** is deasserted.
- Transactions with write data must have all byte strobes asserted within the cache line container.



## A9.3 Cache coherency and Domains

When multiple Managers share data, writes from those Managers must be coherent. This means writes to the same address location by two Managers are observable in the same order by all participating Managers.

If a system contains caches, measures must be taken to ensure that cached values do not become stale.

In AMBA, this can be achieved in three ways:

- Using Non-cacheable transactions.
- Software coherency with manual cache maintenance.
- Hardware coherency with snooping and automatic cache maintenance.

AXI supports these by attributing a Domain to every address location, this can be System, Non-shareable or Shareable. There must be a consistent definition of:

- Which address locations are in each Domain.
- Which Domain an address location is attributed.

### A9.3.1 System Domain

Address locations in the System Domain must be visible to all Managers that are able to access them. This is achieved by ensuring that all System Domain requests are Non-cacheable and therefore not stored in any local caches. Using the System Domain makes coherency simple but is generally not high performance.

Requests to Device type memory are required to use the System Domain.

### A9.3.2 Non-shareable Domain

Address locations in the Non-shareable Domain are not required to be visible to other Managers. Transactions to Non-shareable locations do not need to trigger hardware coherency mechanisms to ensure visibility.

If Non-shareable data is to be shared between Managers, then transactions known as Cache Maintenance Operations (CMOs) must be issued to clean and invalidate the data from any local caches before it is read. See [Chapter A10 Cache maintenance](#) for more details.

Data sharing using CMOs is known as software coherency and can be an efficient approach if the sharing behavior between Managers is known. For example, if there are predictable data sets that are written by one agent then read by another. The main disadvantage of this approach is that it relies on software being correct. Coherency bugs in software can be easy to introduce and difficult to debug.

To avoid a loss of coherency, there are some rules when caching Non-shareable lines:

- The eviction and write-back of Clean Non-shareable data is not permitted. This is to avoid a Clean line from overwriting a Dirty line in a downstream cache that was written by another Manager.
- The passing of Dirty data on a read of a Non-shareable line from one cache to another is not permitted. The line must be passed as Clean and responsibility for writing back the line remains with the downstream cache. This avoids a subsequent write-back of the line from overwriting a later update from another Manager.

### A9.3.3 Shareable Domain

Address locations in the Shareable Domain must be visible to all other Managers that also have those locations marked as Shareable. Requests with the Shareable attribute must snoop local caches and lookup in caches that might contain Shareable data from other Managers.

There are two reasons why an AXI component may need to support the Shareable Domain: to enable I/O coherency and to support the movement of Shareable cache lines between upstream and downstream caches. These cases are covered in [A9.4 I/O coherency](#) and [A9.5 Caching Shareable lines](#).

Requests in the Shareable domain can use a Burst type of INCR or WRAP, not FIXED.

### A9.3.4 Domain signaling

Domain signaling is optional, if an interface does not have Domain signaling then Non-cacheable requests are assumed to be in the System Domain and Cacheable requests are assumed to be in the Non-shareable Domain.

If a component is required to support the Shareable Domain, it must include the Domain signaling.

The `Shareable_Transactions` property is used to describe whether an interface supports the Shareable Domain and therefore has Domain signaling.

**Table A9.3: Shareable\_Transactions property**

Shareable_Transactions	Default	Description
True		Shareable domain supported, AxDOMAIN signals are on the interface.
False	Y	Shareable domain not supported, AxDOMAIN signals are not on the interface.

When `Shareable_Transactions` is True, the following signals are included on the interface.

**Table A9.4: AxDOMAIN signals**

Name	Width	Default	Description
AWDOMAIN, ARDOMAIN	2	0b00 for Cacheable requests 0b11 for Non-cacheable requests	Shareability domain of a request.

`Shareable_Transactions` is encoded on the `AxDOMAIN` signals as shown in [Table A9.5](#).

**Table A9.5: AxDOMAIN encodings**

AxDOMAIN	Label	Meaning
0b00	Non-shareable	Non-shareable domain
0b01	Shareable	Shareable domain
0b10	Shareable	Shareable domain
0b11	System	System domain

In previous versions of this specification, `AxDOMAIN` values of 0b01 and 0b10 indicated Inner Shareable and Outer Shareable respectively. In this version, it is recommended that 0b10 is used to indicate the Shareable domain.

Guidance for connecting Manager and Subordinate interfaces with different values of `Shareable_Transactions` is shown in [Table A9.6](#).

**Table A9.6: Shareable\_Transactions interoperability**

	<b>Subordinate: False</b>	<b>Subordinate: True</b>
<b>Manager: False</b>	Compatible.	Compatible if logic is added to generate default <b>AxDOMAIN</b> values from <b>AxCACHE</b> .
<b>Manager: True</b>	Compatible. <b>AxDOMAIN</b> outputs are unconnected.	Compatible.

### A9.3.5 Domain consistency

An address location can be marked as Shareable for one agent and Non-shareable for another. To avoid a loss of coherency, data cached as Non-shareable must be made visible using CMOs before being accessed by an agent that has the location marked as Shareable.

### A9.3.6 Domains and memory types

The combination of Domain and memory type determines which caches must be accessed to complete the transactions.

Legal combinations of memory type and Domain are shown in [Table A9.7](#). The table also indicates which caches must be accessed when processing a request.

- Peer caches are those which are accessed using snoop requests, this requires a coherent protocol such as AMBA CHI [5].
- Inline caches are those which requests pass through while progressing towards memory.

**Table A9.7: Legal combinations of memory type and Domain**

<b>Memory type</b>	<b>Domain</b>	<b>Caches accessed</b>
Device (AxCACHE[3:1] == 0b000)	System	None
	Non-shareable	None
Normal Non-cacheable (AxCACHE[3:1] == 0b001)	Shareable	Peer caches
	System (recommended)	None
Normal Cacheable (AxCACHE[3:2] != 0b00)	Non-shareable	Inline caches
	Shareable	Inline and peer caches

Note that Normal Non-cacheable Shareable is permitted but not expected. Some implementations might not look up in peer caches for Non-cacheable accesses.

## A9.4 I/O coherency

An I/O coherent Manager can read and write data in the Shareable Domain through use of a coherent interconnect but it cannot be snooped, so it must not cache Shareable data. AXI does not support data snooping, so the coherent interconnect will typically be based on the AMBA CHI protocol [5] with AXI interfaces for connecting I/O coherent Managers.

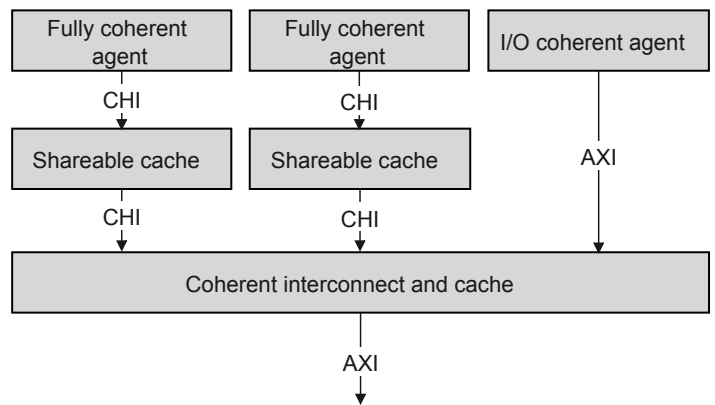

**Figure A9.2: Example use of I/O coherency**

When an I/O coherent Manager issues a Shareable read request, the coherent interconnect tries to find the data by snooping appropriate coherent caches and checking Shareable lines within its caches. If the data cannot be found, a request is sent downstream towards memory. When the data is returned, it must not be cached by the I/O coherent Manager because the data can become stale.

When an I/O coherent Manager issues a Shareable write request (WriteUniquePtl or WriteUniqueFull), the coherent interconnect issues clean and invalidation requests to the coherent caches to ensure that there are no local copies. It then writes the data into a cache or towards memory. For a partial cache line write, any Dirty data found in coherent caches can be merged with the write.

The Shareable\_Cache\_Support property must be False for an I/O coherent interface.

## A9.5 Caching Shareable lines

An AXI-based cache that is downstream of a coherent interconnect has the option to store Shareable lines in addition to Non-shareable cache lines. This has the advantages that:

- Clean evictions of Shareable lines can be cached but must not be written back to memory.
- Dirty data from Shareable lines can be passed to upstream Shareable caches.

To enable this, additional Opcodes and responses are required. The cache must also track which lines are Shareable if it also stores lines from the Non-shareable Domain. In this case, a valid cache line can have one of four states:

- Clean
- Dirty
- Shareable Clean
- Shareable Dirty

The rules regarding which Opcodes can hit which cache lines are shown in [Table A9.8](#).

**Table A9.8: Rules for caching Shareable lines**

Opcode	Domain	Cache state			
		Clean	Dirty	Shareable Clean	Shareable Dirty
Read*	Non-shareable	Permitted to hit	Permitted to hit	Must not hit	Permitted to hit <sup>1</sup>
	Shareable	Permitted to hit	Must hit	Permitted to hit	Must hit <sup>2</sup>
Write*	Non-shareable	Must hit	Must hit	Must not hit	Permitted to hit <sup>1</sup>
	Shareable	Must hit	Must hit	Must hit	Must hit
CleanShared*	Non-shareable	Permitted to hit	Must hit	Permitted to hit	Permitted to hit
	Shareable	Permitted to hit	Must hit	Permitted to hit	Must hit
CleanInvalid* / MakeInvalid	Non-shareable	Must hit	Must hit	Permitted to hit <sup>3</sup>	Permitted to hit <sup>3</sup>
	Shareable	Must hit	Must hit	Must hit	Must hit
InvalidateHint / Prefetch	Non-shareable	Permitted to hit	Permitted to hit	Permitted to hit	Permitted to hit
	Shareable	Permitted to hit	Permitted to hit	Permitted to hit	Permitted to hit
StashOnce*	Non-shareable	Permitted to hit	Permitted to hit	Must not hit	Permitted to hit
	Shareable	Permitted to hit	Permitted to hit	Permitted to hit	Permitted to hit

\* Includes all variants of the Opcode.

<sup>1</sup> The line must no longer be marked as Shareable.

<sup>2</sup> Dirty data can be provided upstream if the request was ReadShared.

<sup>3</sup> *Must hit* if RME\_Support is True.

### A9.5.1 Opcodes to support reading and writing full cache lines

The following Opcodes can be used to read and write full cache lines of data. Transactions using these Opcodes must be cache line sized and Regular. For write transactions all write strobes must be asserted.

#### **ReadClean**

A full cache line read from a Shareable location, where the data is likely to be allocated in an upstream cache. The read data must be Clean.

This Opcode can be used if the `Shareable_Cache_Support` and `Shareable_Transactions` properties are both True.

#### **ReadShared**

A full cache line read from a Shareable location, where the data is likely to be allocated in an upstream cache. The read data can be Clean or Dirty. If the data is Dirty, the line must be allocated upstream, and the response for all transfers of read data must be OKAYDIRTY instead of OKAY.

This Opcode can be used if the `Shareable_Cache_Support` and `Shareable_Transactions` properties are both True.

#### **WriteNoSnoopFull**

A Non-shareable write of a full cache line where the data is Dirty and not allocated upstream.

An upstream cache can issue a WriteNoSnoopFull transaction when it evicts a Non-shareable Dirty cache line or when streaming write data which is cache line sized. If a downstream cache receives a WriteNoSnoopFull request, it can allocate the line knowing that the line is not allocated upstream.

This Opcode can be used if the `WriteNoSnoopFull_Transaction` or `Shareable_Cache_Support` property is True.

**Table A9.9: WriteNoSnoopFull\_Transaction property**

<code>WriteNoSnoopFull_Transaction</code>	Default	Description
True		WriteNoSnoopFull is supported.
False	Y	WriteNoSnoopFull is not supported unless <code>Shareable_Cache_Support</code> is True.

#### **WriteUniqueFull**

A Shareable write of a full cache line where the data is Dirty but was not allocated upstream. This transaction is used by an I/O coherent Manager to write to a cache line that might be stored in a cache within the coherent domain. A system cache can allocate the line as Shareable Dirty.

This Opcode can be used if the `Shareable_Transactions` property is True.

#### **WriteBackFull**

A WriteBackFull transaction can be used when a Shareable Dirty line is evicted from a coherent cache. This transaction enables a system cache to allocate the line as Shareable Dirty.

This Opcode can be used if the `Shareable_Cache_Support` and `Shareable_Transactions` properties are both True.

#### **WriteEvictFull**

A WriteEvictFull transaction can be used when a Shareable Clean line is evicted from a coherent cache. This transaction enables a system cache to allocate the line as Shareable Clean.

A Shareable Clean line must not be exposed to any agents outside of the Shareable Domain because the line might become stale within caches in the Shareable Domain. For the same reason, data from a WriteEvictFull must not update memory.

This Opcode can be used if the Shareable\_Cache\_Support and Shareable\_Transactions properties are both True.

## A9.5.2 Configuration of Shareable cache support

The Shareable\_Cache\_Support property is used to indicate whether an interface supports the additional transaction Opcodes required for the storage of coherent cache lines.

**Table A9.10: Shareable\_Cache\_Support property**

Shareable_Cache_Support	Default	Description
True		Additional Opcodes for Shareable cache lines are supported.
False	Y	Additional Opcodes for Shareable cache lines are not supported.

The compatibility between Manager and Subordinate interfaces according to the values of the Shareable\_Cache\_Support property is shown in [Table A9.11](#).

**Table A9.11: Shareable\_Cache\_Support compatibility**

Shareable_Cache_Support	Subordinate: False	Subordinate: True
Manager: False	Compatible.	Compatible.
Manager: True	Incompatible. Alternative Opcodes must be used.	Compatible.

Shareable requests can also be controlled at reset-time using an optional Manager input signal, **BROADCASTSHAREABLE**.

**Table A9.12: BROADCASTSHAREABLE signal**

Name	Width	Default	Description
BROADCASTSHAREABLE	1	0b1	Manager tie-off input, used to control the issuing of Shareable transactions from an interface.

When **BROADCASTSHAREABLE** is present and deasserted, all transactions are converted to Non-shareable equivalents before they are sent, as shown in [Table A9.13](#).

**Table A9.13: Opcode alternatives**

Opcode	BROADCASTSHAREABLE is LOW
WriteUniquePtl	WriteNoSnoop
WriteUniqueFull	WriteNoSnoop or WriteNoSnoopFull

WriteBackFull	WriteNoSnoop or WriteNoSnoopFull
WriteEvictFull	- (request must be dropped)
CMO (Shareable)	CMO (Non-shareable)
WriteUniquePtlStash	WriteNoSnoop
WriteUniqueFullStash	WriteNoSnoop or WriteNoSnoopFull
WritePtlCMO (Shareable)	WritePtlCMO (Non-shareable)
StashOnceShared (Shareable)	StashOnceShared (Non-shareable)
StashOnceUnique (Shareable)	StashOnceUnique (Non-shareable)
Prefetch (Shareable)	Prefetch (Non-shareable)
ReadOnce	ReadNoSnoop
ReadShared	ReadNoSnoop
ReadClean	ReadNoSnoop
ReadOnceCleanInvalid	ReadNoSnoop
ReadOnceMakeInvalid	ReadNoSnoop



## A9.6 Prefetch transaction

When a Manager has indication that it might need data for an address but does not want to commit to reading it yet, it can send a Prefetch request to the system that it might be advantageous to prepare the location for reading. This request to the system can cause the allocation of data into a downstream cache or from off-chip memory before the Manager makes the actual read request.

The Prefetch request is not required to be ordered with respect to other requests such as CMOs, therefore a Prefetch must not be used to signal that a line can be fetched into a managed or visible cache.

The PREFETCHED response to a read request indicates that the transaction has hit upon prefetched data. The Manager can use this as part of a heuristic to determine if it continues issuing Prefetch requests.

In AMBA CHI [5], the equivalent of a Prefetch request is PrefetchTgt which can be issued alongside a coherent request to the same address. The PrefetchTgt can bypass any coherency checks and cause the memory controller to prefetch the data in case the coherent request does not find the data in any shared caches. If the memory controller uses an AXI interface, the CHI PrefetchTgt request can be converted to an AXI Prefetch.

### A9.6.1 Rules for the prefetch transaction

A Prefetch is a data-less transaction, the rules are:

- The Prefetch transaction consists of a request on the AW channel and a single response transfer on the B channel, there is no data transfer.
- A Prefetch request is signaled using the **AWSNOOP** Opcode of 0b011111.
- A Prefetch request must be cache line sized with the following constraints:
  - The transaction is Regular, see [A4.1.8 Regular transactions](#).
  - **AWCACHE[1]** is asserted, that is a Normal transaction.
  - **AWDOMAIN** is Non-shareable or Shareable.
  - **AWLOCK** is deasserted, not exclusive access.
- The ID value must be unique-in-flight, which means:
  - A Prefetch request can only be issued if there are no outstanding write transactions using the same **AWID**.
  - The Manager must not issue a request on the write channel with the same **AWID** as an outstanding Prefetch request.
  - If present on the interface, **AWIDUNQ** must be asserted for Prefetch transactions.
- The Manager may or may not follow a Prefetch request with a non-Prefetch request to the same address.
- A Subordinate interface at any level can chose to propagate or respond to a Prefetch request.
- It is permitted to respond to a Prefetch request with OKAY, DECERR, SLVERR, or TRANSFAULT. An OKAY response can be sent irrespective of whether the Subordinate acts on the Prefetch request.

The Prefetch\_Transaction property is used to indicate whether a component supports the Prefetch Opcode as shown in [Table A9.14](#).

**Table A9.14: Prefetch\_Transaction property**

Prefetch_Transaction	Default	Description
True		Prefetch is supported.
False	Y	Prefetch is not supported.

### A9.6.2 Response for prefetched data

If a read request hits on data which has been prepared due to a previous Prefetch request, the Subordinate may return a PREFETCHED response. This can be used by the Manager to determine the success rate of its Prefetch requests.

The PREFETCHED response has the following rules and recommendations:

- The PREFETCHED response is signaled using **RRESP** encoding of 0b100.
- When Prefetch\_Transaction is True, RRESP\_WIDTH must be 3 to enable the signaling of the PREFETCHED response.
- PREFETCHED indicates that read data is valid and has come from a prefetched source.
- PREFETCHED can be used for a response to the following transaction types:
  - ReadNoSnoop
  - ReadOnce
  - ReadClean
  - ReadShared
  - ReadOnceCleanInvalid
  - ReadOnceMakeInvalid
- A PREFETCHED response cannot be sent for an exclusive read.
- It is recommended that within a cache line, the PREFETCHED response is used for all data transfers or no data transfers. If a transaction spans cache lines, there can be a mixture of PREFETCHED and other responses for each cache line accessed.
- A PREFETCHED response can only be sent if the Prefetch\_Transaction property is True for the interface.
- A PREFETCHED response can be sent to a Manager even if the Manager has not sent a Prefetch request to that location. For example, if a Manager happens to read data which was prefetched by another Manager.

## A9.7 Cache Stashing

Cache stashing enables one component to indicate that data should be placed in another cache in the system. This technique can be used to ensure that data is located close to its point of use, potentially improving the performance of the overall system. The AXI protocol supports cache stashing requests with or without a stash target identifier.

Cache stashing is a hint. A cache, or system component can choose to ignore the stash part of a request.

I/O coherent AXI Managers can request that data is stashed in fully coherent Managers with AMBA CHI interfaces [5].

### A9.7.1 Stash transaction Opcodes

There are four Opcodes that can be used for cache stashing.

#### ***WriteUniquePtlStash***

Write to a Shareable location with an indication that the data should be allocated into a cache. Any number of bytes within the cache line can be written, including all bytes or zero bytes.

#### ***WriteUniqueFullStash***

Write a full cache line of data to a Shareable location with an indication that the data should be allocated into a cache. The transaction must be cache line sized and Regular. All write strobes must be asserted.

#### ***StashOnceShared***

A data-less transaction which indicates that a cache line should be fetched into a particular cache. Other copies of the line are not required to be invalidated.

#### ***StashOnceUnique***

A data-less transaction which indicates that a cache line should be fetched into a particular cache. It is recommended that all other copies are invalidated.

A StashOnceUnique transaction can cause the invalidation of a cached copy of a cache line and care must be taken to ensure that such transactions do not interfere with exclusive access sequences.

For an interface that supports the Untranslated Transactions feature, an extra stash transaction is supported. The StashTranslation transaction is used to indicate to a *System Memory Management Unit* (SMMU) that a translation should be obtained for the address that is supplied with the StashTranslation transaction. See [A14.7 StashTranslation Opcode](#).

### A9.7.2 Stash transaction signaling

Stash requests are signaled on the write request channel and have a single response transfer on the write response channel. Write with stash transactions also include write data.

A stash request has constraints on Domain, Size, and Length shown in [Table A9.15](#). Cache stash transactions are not permitted to cross a cache line boundary.

**Table A9.15: Domain, Size, and Length constraints for stash requests**

Opcode	AWSNOOP	Domain	Size, Length
WriteUniquePtlStash	0b1000	Shareable	Cache size or smaller
WriteUniqueFullStash	0b1001	Shareable	Cache line sized and Regular
StashOnceShared	0b1100	Non-shareable, Shareable	Cache line sized and Regular
StashOnceUnique	0b1101	Non-shareable, Shareable	Cache line sized and Regular

The following constraints also apply to all stash request Opcodes:

- **AWCACHE[1]** is 0b1 (Modifiable)
- **AWLOCK** is 0b0 (not exclusive access)
- **AWTAGOP** is 0b00 (Invalid)
- **AWATOP** is 0b000000 (Non-atomic operation)

### A9.7.3 Stash request Domain

The Domain of a stash request determines which caches are checked for the cache line and how the line should be fetched and stored.

A stash request to a Shareable location implies that the line can be stored in a peer or inline cache. If the stash request causes a cache to issue a downstream request, it should be Shareable if possible. Writes with stash must always be to a Shareable location.

A stash request to a Non-shareable location implies that the line can be stored in an inline cache. If the stash request causes a cache to issue a downstream request, it must be Non-shareable. StashOnceShared and StashOnceUnique Opcodes can be to Shareable or Non-shareable locations.

### A9.7.4 Stash target identifiers

A stash request can optionally include target identifiers to indicate a specific cache that is preferred for the data to be stored. This specification does not define the precise details of this identification mechanism. It is expected that any agent that is performing a stash operation knows the identifier to use for a given stash transaction.

This specification defines two levels of identification:

- A Node ID to identify the physical interface that the cache stash should be sent to.
- A Logical Processor ID to identify a functional unit that is associated with that physical interface.

For example, a stash transaction can specify a processor cluster interface and specific cache within that cluster.

The signals used to indicate stash targets are shown in [Table A9.16](#).

**Table A9.16: Signals used to indicate stash targets**

Name	Width	Default	Description
AWSTASHNID	11	All zeros	Node Identifier of the target for a stash operation.
AWSTASHNIDEN	1	0b0	HIGH to indicate that the AWSTASHNID signal is valid.
AWSTASHLPID	5	0x00	Logical Processor Identifier within the target for a stash operation.
AWSTASHLPIDEN	1	0b0	HIGH to indicate that the AWSTASHLPID signal is valid.

The Node ID and Logical Processor ID signals are optional on an interface, controlled using the STASHNID\_Present and STASHLPID\_Present properties, respectively.

**Table A9.17: STASHNID\_Present property**

STASHNID_Present	Default	Description
True		AWSTASHNID and AWSTASHNIDEN are present.
False	Y	AWSTASHNID and AWSTASHNIDEN are not present.

**Table A9.18: STASHLPID\_Present property**

STASHLPID_Present	Default	Description
True		AWSTASHLPID and AWSTASHLPIDEN are present.
False	Y	AWSTASHLPID and AWSTASHLPIDEN are not present.

Each stash target identifier has an enable signal so NID and LPID can be controlled independently.

- For stash transactions, any combination of target enables is permitted.
- For non-stash transactions, **AWSTASHLPIDEN** and **AWSTASHNIDEN** must be LOW.
- When **AWSTASHNIDEN** is LOW, **AWSTASHNID** is invalid and must be zero.
- When **AWSTASHLPIDEN** is LOW, **AWSTASHLPID** is invalid and must be zero.
- It is permitted, but not recommended to send a stash transaction with a stash target that indicates a

component that does not support cache stashing. The indication of a stash target within a stash transaction does not affect which components are permitted to access and cache a given cache line.

For WriteUniquePtlStash and WriteUniqueFullStash requests without a target, the following is recommended:

- If the interconnect can determine that the line is held in a single cache before the write occurs, then stash the cache line back to that cache.
- If the cache line is not held in any cache before the write occurs, then stash the cache line in a shared system cache.

For StashOnceShared and StashOnceUnique requests without a target:

- If the interconnect can determine that the cache line is not in any cache, then it is recommended to stash the cache line in a shared system cache.
- A component can use this to prefetch a cache line to a downstream cache for its own use.

### A9.7.5 Transaction ID for stash transactions

There are no constraints on the use of AXI ID values for WriteUniquePtlStash and WriteUniqueFullStash transactions.

StashOnceShared and StashOnceUnique can be referred to as StashOnce transactions.

StashOnce transactions must not use the same AXI ID values that are used by non-StashOnce transactions that are outstanding at the same time. This rule ensures that there are no ordering constraints between StashOnce transactions and other transactions. Therefore, a component that discards a StashOnce request can give an immediate response without checking ID ordering requirements.

StashOnce transactions and non-StashOnce transactions are permitted to use the same AXI ID value, provided that the same ID value is not used by both a StashOnce transaction and a non-StashOnce at the same time.

There can be multiple outstanding StashOnce transactions with the same ID.

There can be multiple outstanding non-StashOnce transactions with the same ID.

The use of a unique ID value for a StashOnce transaction ensures that these transactions can be given an immediate response if they are not supported.

### A9.7.6 Support for stash transactions

The `Cache_Stash_Transactions` property is used to indicate whether an interface supports cache stashing, as shown in [Table A9.19](#).

**Table A9.19: Cache\_Stash\_Transactions property**

<code>Cache_Stash_Transactions</code>	Default	Description
True		All cache stashing Opcodes are supported. There may or may not be a stash target.
Basic		Only the <code>StashOnceShared</code> Opcode is supported. A stash target is not permitted, <code>STASHLPID_Present</code> and <code>STASHNID_Present</code> must be False.
False	Y	Cache stashing is not supported and associated signals are omitted.

When `Cache_Stash_Transactions` is False, `STASHNID_Present` and `STASHLPID_Present` must both be False.

The compatibility between Manager and Subordinate interfaces according to the values of the `Cache_Stash_Transactions` property is shown in [Table A9.20](#).

**Table A9.20: Stash transactions compatibility**

<code>Cache_Stash_Transactions</code>	Subordinate: False	Subordinate: Basic	Subordinate: True
<b>Manager: False</b>	Compatible.	Compatible.	Compatible.
<b>Manager: Basic</b>	Incompatible, action must be taken.	Compatible.	Compatible.
<b>Manager: True</b>	Incompatible, action must be taken.	Incompatible, action must be taken.	Compatible.

If a Manager issues stash requests to a target that does not support them, action can be taken in the Manager or interconnect as shown in [Table A9.21](#).

**Table A9.21: Action needed if the target does not support stash transactions**

Stash transaction	Action
<code>WriteUniquePtlStash</code>	Convert to <code>WriteUniquePtl</code> .
<code>WriteUniqueFullStash</code>	Convert to <code>WriteUniqueFull</code> .
<code>StashOnceShared</code>	Do not propagate and give an immediate response.
<code>StashOnceUnique</code>	Do not propagate and give an immediate response.

## A9.8 Deallocating read transactions

Deallocating read transactions can be used when a Manager requires data which is not likely to be used again by any Manager. A cache can use this as a hint to evict the line and make the resource available for other data.

The `DeAllocation_Transactions` property is used to indicate whether a component supports deallocating transactions as shown in [Table A9.22](#).

Interoperability between a component that issues deallocating transactions and a component that does not support them can be performed by converting the Opcode to `ReadOnce`.

**Table A9.22: `DeAllocation_Transactions` property**

<code>DeAllocation_Transactions</code>	Default	Description
True		Deallocating transactions are supported.
False	Y	Deallocating transactions are not supported.

### A9.8.1 Deallocating read Opcodes

This specification defines two deallocating transaction Opcodes on the read request channel:

#### ***ReadOnceCleanInvalid (ROCI)***

This request reads a snapshot of the current value of the cache line. It is recommended, but not required that any cached copy of the cache line is deallocated. If a Dirty copy of the cache line exists, and the cache line is deallocated, then the Dirty copy must be written back to main memory.

`ReadOnceCleanInvalid` is signaled using an **ARSNOOP** value of `0b0100`.

#### ***ReadOnceMakeInvalid (ROMI)***

This request reads a snapshot of the current value of the cache line. It is recommended, but not required that any cached copy of the cache line is deallocated. It is permitted, but not required that a Dirty copy of the cache line is discarded. The Dirty copy of the cache line does not need to be written back to main memory.

`ReadOnceMakeInvalid` is signaled using an **ARSNOOP** value of `0b0101`.

### A9.8.2 Rules and recommendations

Deallocating transactions are only permitted to access one cache line at a time and are not permitted to cross a cache line boundary. Size must be cache line sized or smaller.

A ROMI request to part of a cache line can result in the invalidation of the entire cache line. Some implementations might not support the deallocation behavior for transactions that are less than a cache line and instead convert the transaction to `ReadOnce` in such cases.

ROCI and ROMI are only supported to the Shareable Domain, so the `Shareable_Transactions` property must be True if `DeAllocation_Transactions` is True.

For a ROMI transaction, it is required that the invalidation of the cache line is committed before the return of the first item of read data for the transaction. The invalidation of the cache line is not required to have completed at this point. However, it must be ensured that any later write transaction from any agent that starts after this point, is guaranteed not to be invalidated by this transaction.

The following considerations apply to the use of deallocating transactions:



- Caution is needed when deallocating transactions are issued to the same cache line that other agents are using for exclusive accesses. This is because the deallocation can cause an exclusive sequence to fail.
- Apart from the interaction with exclusive accesses, the ROCI transaction only provides a hint for deallocation of a cache line and has no other impact on the correctness of a system.
- The use of the ROMI transaction can cause the loss of a Dirty cache line. The use of this transaction must be strictly limited to scenarios when it is known that it is safe to do so.
- Deallocating transactions do not guarantee that a cache line will be cleaned or invalidated, so cannot be used to ensure that data is visible to all observers.

## A9.9 Invalidate hint

The InvalidateHint transaction is a data-less deallocation hint. It can be used when a Manager has finished working with a data set and that data might be allocated in a downstream cache. An InvalidateHint request informs the cache that the line is no longer required and can be invalidated. A write-back of the line is permitted but not required.

InvalidateHint is not required to be executed for functional correctness, so can be terminated at any point in the system by responding with **BRESP** of OKAY.

Care is needed when using an InvalidateHint transaction to avoid exposure of previously overwritten values. This can be achieved either by:

- Ensuring that a clean operation following a scrubbing write ensures that the write has been propagated sufficiently far that it is not removed by the Invalidate Hint transaction.
- Ensuring the use of the InvalidateHint transaction is limited to address ranges that will not contain sensitive information.

### A9.9.1 Invalidate Hint signaling

InvalidateHint is a data-less transaction using AW and B channels.

The following constraints apply to an InvalidateHint request:

- **AWSNOOP** is 0b10010.
  - **AWSNOOP** must be 5b wide if the InvalidateHint\_Transaction property is True.
- **AWDOMAIN** can be Non-shareable or Shareable.
- **AWBURST** is INCR.
- **AWSIZE** and **AWLEN** must be cache line sized and Regular.
- **AWCACHE** is Normal Cacheable.
- **AWID** is unique-in-flight, which means:
  - An InvalidateHint request can only be issued if there are no outstanding transactions on the write channels using the same ID value.
  - A Manager must not issue a request on the write channels with the same ID as an outstanding InvalidateHint transaction.
  - If present, **AWIDUNQ** must be asserted for an InvalidateHint request.
- **AWLOCK** is deasserted, not an exclusive access.
- **AWTAGOP** is Invalid.
- **AWATOP** is Non-atomic operation.

## A9.9.2 Invalidate Hint support

The `InvalidateHint_Transaction` property is used to indicate whether an interface supports the `InvalidateHint` transaction, as shown in [Table A9.23](#).

**Table A9.23: InvalidateHint\_Transaction property**

<code>InvalidateHint_Transaction</code>	Default	Description
True		<code>InvalidateHint</code> is supported.
False	Y	<code>InvalidateHint</code> is not supported.

The compatibility between Manager and Subordinate interfaces according to the values of the `InvalidateHint_Transaction` property is shown in [Table A9.24](#).

**Table A9.24: InvalidateHint\_Transaction compatibility**

<code>InvalidateHint_Transaction</code>	Subordinate: False	Subordinate: True
Manager: False	Compatible.	Compatible.
Manager: True	Not compatible. An adapter that responds OKAY to <code>InvalidateHint</code> could be used to make it compatible.	Compatible.

## Chapter A10

# Cache maintenance

This chapter describes cache maintenance operations (CMOs) that assist with software cache management.

It contains the following sections:

- [A10.1 Cache Maintenance Operations](#)
- [A10.2 Actions on receiving a CMO](#)
- [A10.3 CMO request attributes](#)
- [A10.4 CMO propagation](#)
- [A10.5 CMOs on the write channels](#)
- [A10.6 Write with CMO](#)
- [A10.7 CMOs on the read channels](#)
- [A10.8 CMOs for Persistence](#)
- [A10.9 Cache Maintenance and Realm Management Extension](#)
- [A10.10 Processor cache maintenance instructions](#)

## A10.1 Cache Maintenance Operations

Cache maintenance operations are requests that instruct caches to clean and invalidate cache lines. Unlike the allocation and deallocation hints, it is mandatory that a cache actions a CMO that targets a line it has cached.

CMOs can be transported on either the read or write channels.

Transporting CMOs on read channels is included in this specification to support legacy components. It is recommended that the new designs transmit CMOs on the write channels.

The specification supports the following cache maintenance operations.

### ***CleanShared (CS)***

When completed, all cached copies of the addressed line are Clean and any associated writes are observable.

### ***CleanSharedPersist (CSP)***

When completed, all cached copies of the addressed line are Clean and any associated writes are observable and have reached the Point of Persistence (PoP). See [A10.8 CMOs for Persistence](#).

### ***CleanSharedDeepPersist (CSDP)***

When completed, all cached copies of the addressed line are Clean and any associated writes are observable and have reached the Point of Deep Persistence (PoDP). See [A10.8 CMOs for Persistence](#).

### ***CleanInvalid (CI)***

When completed, all cached copies of the addressed line are invalidated, having been written to memory if they were Dirty. Any associated writes are observable.

### ***CleanInvalidPoPA (CIPA)***

When completed, all cached copies of the addressed line are invalidated, and any Dirty cached copy is written past the Point of Physical Aliasing (PoPA). See [A10.9 Cache Maintenance and Realm Management Extension](#).

### ***MakeInvalid (MI)***

When completed, all cached copies of the addressed line are invalidated, and any Dirty cached copy might have been discarded.

## A10.2 Actions on receiving a CMO

When a component receives a CMO, it must do the following:

1. If the component is a cache and the CMO is cacheable, it must look up the line.
2. If the component is a coherent interconnect and the CMO is Shareable, a CMO snoop must be sent to any cache that might have the line:
  - Allocated, for an Invalidate CMO
  - Dirty, for a Clean CMO

Note that a coherent protocol such as AMBA CHI [5] is required to send CMO snoop requests.

3. For a Clean CMO, write back any dirty data that is found in the cache or peer caches.

It is recommended that Write-Through No-Allocate is used for writes to memory which will be followed by a CMO to the same line. This ensures that the line will be looked up in any downstream cache but will not be allocated.
4. Wait for all snoops and associated writes to receive a response.
5. If the CMO does not need to be sent downstream, the component can issue a response to the CMO.
6. If the CMO does need to be sent downstream, the CMO must be sent and the response that is returned must be propagated when it is received from downstream.

## A10.3 CMO request attributes

The following rules apply to CMO transactions:

- The request must be cache line sized and Regular. See [A4.1.8 Regular transactions](#) for more details.
- The Domain can be Non-shareable or Shareable.
  - System Domain is not permitted, which means that CMO transactions must be Normal rather than Device.

The **AxCACHE** and **AxDOMAIN** attributes indicate which caches must action a CMO, as shown in [Table A10.1](#).

**Table A10.1: CMO applicability**

<b>AxCACHE</b>	<b>AxDOMAIN</b>	<b>CMO applies to</b>
Device	System	N/A (not legal for CMOs)
Non-cacheable	Non-shareable	No caches
	Shareable	Peer caches
Cacheable	Non-shareable	In-line caches
	Shareable	Peer caches and in-line caches

To maintain coherency, the following recommendations apply to CMOs and non-CMOs:

- If a location is cacheable for non-CMO transactions, it should be cacheable for CMO transactions.
- If a location is in the Shareable Domain for non-CMO transactions, it should be in the Shareable Domain for CMO transactions.
- If a location is in the Non-shareable Domain for non-CMO transactions, it can be in the Non-shareable or Shareable Domain for CMO transactions.
- A Manager should not issue a read request that permits it to allocate a line, while there is an outstanding CMO to that line.
- Allocation hints, such as **AxCACHE[3:2]**, are not required to match between CMO and non-CMO transactions to the same cache line.

## A10.4 CMO propagation

The propagation of CMOs downstream of components, depends on the system topology. A CMO must be propagated downstream if the CMO is cacheable and there is a downstream cache which might have allocated the line and there is an observer downstream of that cache.

Two mechanisms are defined for controlling whether CMOs are propagated from a Manager interface.

- At design-time, using the properties `CMO_On_Write` or `CMO_On_Read`.
- At run-time, using the optional **BROADCASTCACHEMAINT** and **BROADCASTSHAREABLE** tie-off inputs to a Manager interface.

**Table A10.2: BROADCASTCACHEMAINT signal**

Name	Width	Default	Description
BROADCASTCACHEMAINT	1	0b1	Manager tie-off input, used to control the issuing of CMOs from an interface.

When **BROADCASTCACHEMAINT** and **BROADCASTSHAREABLE** are both present and deasserted:

- `CleanShared`, `CleanInvalid` and `MakeInvalid` requests are not issued.
- `WritePtlCMO` is converted to `WriteNoSnoop`.
- `WriteFullCMO` is converted to `WriteNoSnoop` or `WriteNoSnoopFull`.



## A10.5 CMOs on the write channels

The CMO\_On\_Write property is used to indicate whether an interface supports CMOs on the write channels.

**Table A10.3: CMO\_On\_Write property**

CMO_On_Write	Default	Description
True		CMOs are supported on the AW and B channels.
False	Y	CMOs are not supported on the AW and B channels. They are either signaled on the read channels or not used by this interface.

On the write channels, CMOs can be sent as a stand-alone operation or combined with a data write. The **AWSNOOP** encodings that can be used to signal CMO requests on the AW channel are shown in [Table A10.4](#). For more information on the combined write with CMO operations see [A10.6 Write with CMO](#).

**Table A10.4: AWSNOOP encodings**

AWSNOOP	Operation	Enable property	Description
0b0110	CMO	CMO_On_Write	Stand-alone CMO.
0b1010	WritePtlCMO	Write_Plus_CMO	CMO combined with a write which is less than or equal to one cache line.
0b1011	WriteFullCMO	Write_Plus_CMO	CMO combined with a write which is exactly one cache line.

The **AWCMO** signal indicates the type of CMO that is requested, it is present on the AW channel when CMO\_On\_Write is True.

**Table A10.5: AWCMO signal**

Name	Width	Default	Description
AWCMO	AWCMO_WIDTH	0b000 (CleanInvalid)	Indicates the CMO type for write opcodes that include a cache maintenance operation.

The width of **AWCMO** is determined by the property AWCMO\_WIDTH.

Name	Values	Default	Description
AWCMO_WIDTH	0, 2, 3	0	Width of AWCMO in bits.

The rules for AWCMO\_WIDTH are:

- Must be 0 if CMO\_On\_Write is False. This means that **AWCMO** is not on the interface.
- Must be 2 if CMO\_On\_Write is True and RME\_Support is False.
- Must be 3 if CMO\_On\_Write is True and RME\_Support is True.

The encodings for **AWCMO** are shown in [Table A10.7](#). An encoding cannot be used if the associated enable property is False.

**Table A10.7: AWCMO encodings**

<b>AWCMO</b>	<b>Label</b>	<b>Enable property</b>	<b>Meaning</b>
0b000	CleanInvalid	-	Clean and invalidate
0b001	CleanShared	-	Clean only
0b010	CleanSharedPersist	Persist_CMO	Clean to the Point of Persistence
0b011	CleanSharedDeepPersist	Persist_CMO	Clean to the Point of Deep Persistence
0b100	CleanInvalidPOPA	RME_Support	Clean and invalidate to the Point of Physical Aliasing
0b101 to 0b111	RESERVED	-	-

Note that MakeInvalid is not supported on the write channels.

When **AWSNOOP** is not CMO, WritePtlCMO or WriteFullCMO, **AWCMO** must be 0b000.

A CMO transaction on the write channels consists of a request on the AW channel and a response on the B channel. There are no transfers on the W channel in a CMO transaction.

The write response to the CMOs CleanInvalid and CleanShared have a single response transfer on the B channel. This indicates that all caches are Clean and/or invalid within the specified Domain and any associated writes are observable.

The *Persist* CMOs are described in [A10.8 CMOs for Persistence](#) and *POPA* CMO is described in [A10.9 Cache Maintenance and Realm Management Extension](#).

## A10.6 Write with CMO

Cache maintenance operations are often used with a write to memory. For example:

- A write from an I/O agent which must be made visible to observers which are downstream of caches.
- A write to persistent memory that must ensure that all copies of the line are also cleaned to the point of persistence.
- A CMO that causes a write back of dirty data, which must be followed by the CMO.

A write with CMO combines a write with a CMO to improve the efficiency of this type of scenario. It is expected that some Managers will natively generate a write with CMO. In other cases, a cache or interconnect will combine a CMO with a write before propagating them downstream.

The `Write_Plus_CMO` property is used to indicate whether a component supports combined write and CMOs on the write channels.

**Table A10.8: Write\_Plus\_CMO property**

Write_Plus_CMO	Default	Description
True		Combined write and cache maintenance operations are supported.
False	Y	Combined write and cache maintenance operations are not supported.

If the `Write_Plus_CMO` property is True, the `CMO_On_Write` property must also be True.

When `Write_Plus_CMO` is True, the `WritePtlCMO` and `WriteFullCMO` Opcodes can be used to indicate a write with CMO.

A write with CMO can use any of the CMO types as indicated by **AWCMO**.

Some example uses of write with CMO are shown in the [Table A10.9](#).

**Table A10.9: Examples of write with CMO transactions**

Operation	Primary use-case	Action
Shareable WritePtlCMO with CleanShared	An I/O agent writing less than a cache line to a Shareable region, where the data must be visible to observers downstream of a cache.	All in-line and peer caches must look up the line and write back any dirty data. Data from a Dirty cache line can be merged with the partial write to form a WriteFullCMO with CleanShared to go downstream.
Shareable WriteFullCMO with CleanSharedPersist	An I/O agent writing a cache line to a Shareable region, where the data must reach the Point of Persistence.	The coherent interconnect issues a MakeInvalid snoop to coherent peer caches. In-line caches look up the line and either update or invalidate any copies. The write and CleanSharedPersist must be propagated if there is a Point of Persistence downstream.
Non-shareable WriteFullCMO with CleanInvalid	Issued by a cache when a CleanInvalid CMO has hit a Dirty line and caused a write to memory.	All in-line cache entries must be cleaned and invalidated. The write and CleanInvalid must be propagated if there are observers downstream.

### A10.6.1 Attributes for write with CMO

A write with CMO has the following attribute constraints:

- **AWSNOOP** is 0b1010 to indicate WritePtlCMO and 0b1011 to indicate WriteFullCMO.
- **AWDOMAIN** is Non-shareable or Shareable.
- **AWCACHE[1]** is asserted, the transaction must be Modifiable.
- **AWLOCK** is deasserted, not an exclusive access.

A WriteFullCMO must be cache line sized and Regular, see [A4.1.8 Regular transactions](#).

A WritePtlCMO must be cache line sized or smaller and not cross a cache line boundary. The associated CMO applies to the whole of the addressed cache line. **AWBURST** must not be FIXED.

The cache maintenance part of the write with CMO is always treated as cacheable and Shareable, irrespective of **AWCACHE** and **AWDOMAIN**.

### A10.6.2 Propagation of write with CMO

Propagation of a write with CMO follows the same rules as the propagation of a CMO. It is possible to split a write with CMO into separate write and CMO transactions for propagation downstream. In that case, either:

- The write is issued first, followed by the CMO on the write request channel with the same ID as the write.
- The write is issued first. When the write response is received, the CMO can be issued on the write or read channel.

When splitting a write and CMO, if **AWDOMAIN** is Shareable, then:

- WritePtlCMO becomes WriteUniquePtl.
- WriteFullCMO becomes WriteUniqueFull.

If **AWDOMAIN** is Non-shareable, then the write becomes WriteNoSnoop or WriteNoSnoopFull.

The CMO is sent as cacheable. If there is a downstream cache in the Shareable Domain, the CMO is sent as Shareable.

If there is no cache downstream that requires management by cache maintenance, the CMO part of the transaction can be discarded. If the discarded CMO is a CleanSharedPersist or CleanSharedDeepPersist, the **BCOMP** and **BPERSIST** signals must be set on the write response. See [A10.8 CMOs for Persistence](#) for more details.

### A10.6.3 Response to write with CMOs

Responses to writes with CMOs follow the same rules as CMOs on the write channel.

A write with CI or CS has a single response transfer which indicates that the write and CMO are both observable.

A write with a CSP or CSDP, has one response that indicates that the write is observable and one response that indicates that the write has reached the PoP / PoDP.

As with a standalone CSP/CSDP, a Subordinate can optionally combine the two responses into a single transfer.

A write with CMO is not permitted to use the MTE Match opcode, so a write response that is combined with Persist and Match responses is not necessary. See [A13.2 Memory Tagging Extension \(MTE\)](#) for more details.

### A10.6.4 Example flow with a write plus CMO

As an example of a flow using a write with CMO, Figure A10.1 shows an I/O Coherent Manager issuing a Shareable CleanShared request on the AW channel into a CHI interconnect.

- The snoop generated by the coherent interconnect hits dirty data in the coherent cache.
- The interconnect then issues a Non-shareable WriteFullCMO with CleanShared.
- The system cache looks up the line, overwrites any existing copies and forwards the write request to the memory. The memory does not need to receive CMOs because its data is observable to all agents.
- The memory controller returns an OKAY response when the data is observable, which is propagated back to the Manager.

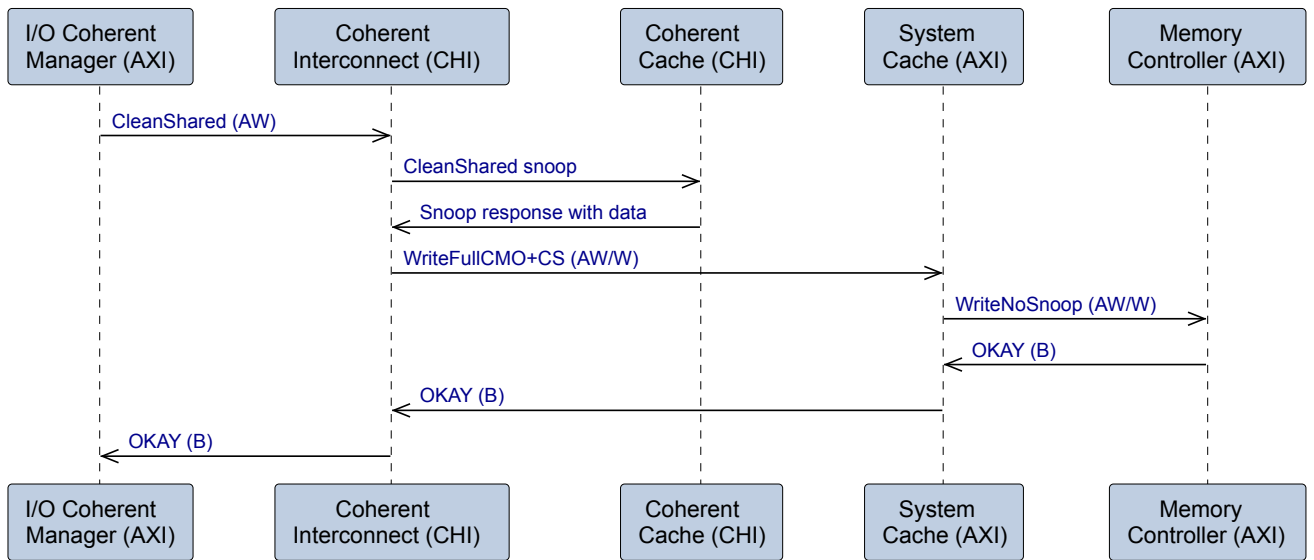

Figure A10.1: Example write with CMO

## A10.7 CMOs on the read channels

The CMO\_On\_Read property is used to indicate whether an interface supports CMOs on the read channels.

**Table A10.10: CMO\_On\_Read property**

CMO_On_Read	Default	Description
True	Y	CMOs are supported on the AR and R channels.
False		CMOs are not supported on the AR and R channels. They are either signaled on the write channels or not used by this interface.

A CMO transaction on the read channels consists of a request on the AR channel and a single transfer response on the R channel. The response indicates that the CMO is observed, and all cache lines have been cleaned and invalidated if necessary.

The **ARSNOOP** encodings used to signal CMO requests on the AR channel are shown in [Table A10.11](#).

**Table A10.11: ARSNOOP encodings**

ARSNOOP	Operation
0b1000	CleanShared
0b1001	CleanInvalid
0b1010	CleanSharedPersist
0b1101	MakeInvalid

## A10.8 CMOs for Persistence

Cache maintenance operations for Persistence are used to provide a cache clean to the Point of Persistence or Point of Deep Persistence. These operations are used to ensure that a store operation, which might be held in a Dirty cache line, is moved downstream to persistent memory.

The `Persist_CMO` property is used to indicate whether a component supports cache maintenance for Persistence.

**Table A10.12: Persist\_CMO property**

<b>Persist_CMO</b>	<b>Default</b>	<b>Description</b>
True		Persistent CMOs are supported.
False	Y	Persistent CMOs are not supported.

Persistent CMOs can be transmitted on either read or write channels, according to the `CMO_On_Write` and `CMO_On_Read` properties.

If `CMO_On_Write` and `CMO_On_Read` are both False, `Persist_CMO` must be False.

### A10.8.1 Point of Persistence and Deep Persistence

In systems with non-volatile memory, each memory location has a point in the hierarchy at which data can be relied upon to be persistent when power is removed. This is known as the Point of Persistence (PoP).

Some systems require multiple levels of guarantee regarding the persistence of data. For example, some data might need the guarantee that it is preserved on power failure and also backup battery failure. To support such a requirement, this specification also defines the Point of Deep Persistence (PoDP).

Systems might have different points for the PoP and PoDP, or they might be the same.

### A10.8.2 Persistent CMO (PCMO) transactions

The specification supports the following PCMO transactions.

#### ***CleanSharedPersist (CSP)***

When this completes, all cached copies of the addressed line in the specified Domain are Clean and any associated writes are observable and have reached the Point of Persistence (PoP).

#### ***CleanSharedDeepPersist (CSDP)***

When this completes, all cached copies of the addressed line in the specified Domain are Clean and any associated writes are observable and have reached the Point of Deep Persistence (PoDP).

When a component receives a PCMO, it is processed in the same way as a CleanShared transaction. If a snoop is required, a CleanShared snoop transaction is used.

### A10.8.3 PCMO propagation

The propagation of PCMOs downstream of components depends on the system topology. A PCMO must be propagated downstream in the following circumstances:

1. If the PCMO is cacheable and there is a downstream cache which might have allocated the cache line and there is an observer downstream of that cache.
2. If there is a PoP downstream of the component.
3. If the PCMO is a CleanSharedDeepPersist and there is a PoDP downstream of the component.

If (1) applies, but not (2) or (3), then a CleanSharedPersist or CleanSharedDeepPersist can be changed to a CleanShared before being sent downstream.

If the PCMO is changed to a CleanShared, the Persist response must be sent by the component doing the transformation.

The propagation of PCMOs can be controlled at reset-time using the optional Manager input **BROADCASTPERSIST**.

**Table A10.13: BROADCASTPERSIST signal**

Name	Width	Default	Description
BROADCASTPERSIST	1	0b1	Manager tie-off input, used to control the issuing of CleanSharedPersist and CleanSharedDeepPersist CMOs.

When **BROADCASTPERSIST** is present and deasserted, CleanSharedPersist and CleanSharedDeepPersist are converted to CleanShared. This applies to standalone CMOs and write with CMOs.

Note that the issuing of the CleanShared is controlled by the **BROADCASTSHAREABLE** and **BROADCASTCACHEMAINT** signals.

### A10.8.4 PCMOs on write channels

When using write channels to transport cache maintenance operations, CleanSharedPersist and CleanSharedDeepPersist are both supported.

#### **PCMO request on the AW channel**

A PCMO request on the write channels is signaled by setting **AWSNOOP** to CMO, WritePtlCMO or WriteFullCMO. See [Table A10.4](#) for encodings.

The **AWCMO** signal then indicates CleanSharedPersist or CleanSharedDeepPersist, see [Table A10.7](#).

When Persist\_CMO is False, **AWCMO** must not indicate CleanSharedPersist or CleanSharedDeepPersist.

#### **PCMO response on the B channel**

CleanSharedPersist and CleanSharedDeepPersist transactions on the AW channel have two responses: a Completion response and a Persist response.

Having separate responses enables system tracking resources to be freed up early, in the case that committing data to the PoP/PoDP takes a long time. The Completion and Persist responses can occur in any order and can be separated by responses from other transactions.



The Completion and Persist responses are signaled using two signals that are included on the write response (B) channel when CMO\_On\_Write and Persist\_CMO are both True.

**Table A10.14: Signals for responding to a PCMO**

Name	Width	Default	Description
BCOMP	1	0b1	Asserted HIGH to indicate a Completion response.
BPERSIST	1	0b0	Asserted HIGH to indicate a Persist response.

The Completion response indicates that all caches are Clean, and any associated writes are observable. It has the following rules:

- **BCOMP** is asserted and **BPERSIST** is deasserted.
- **BID** is driven with the same value as **AWID**.
- If loopback signaling is supported, **BLOOP** is driven from **AWLOOP**.
- If **AWIDUNQ** was asserted, the ID can be reused when this response is received.
- **BRESP** can take any value that is legal for a PCMO request.
- The Completion response must follow normal response ordering rules.
- If **BCOMP** is present on an interface, it must be asserted for one response transfer in all transactions on the write channels.

The Persist response indicates that the data has reached the PoP or PoDP. It has the following rules:

- **BCOMP** is deasserted and **BPERSIST** is asserted.
- **BID** is driven from **AWID**.
- **BIDUNQ** can take any value, it is not required to have the same value as **AWIDUNQ**.
- **BLOOP** can take any value, it is not required to be driven from **AWLOOP**.
- **BRESP** can take any value that is legal for a PCMO request.
- The Persist response has no ordering requirements, it can overtake or be overtaken by other response transfers.
- If **BPERSIST** is present on an interface, it must be asserted for one transfer of a response to a CSP or CSDP. It must be deasserted for all other responses.

A Subordinate can optionally combine the two responses into a single transfer. The following rules apply:

- **BCOMP** and **BPERSIST** are both asserted.
- **BID** is driven from **AWID**.
- If loopback signaling is supported, **BLOOP** is driven from **AWLOOP**.
- **BRESP** can take any value that is legal for a PCMO request.
- The combined response must follow normal response ordering rules.
- If **AWIDUNQ** was asserted, the ID can be reused when this response is received.

A Manager can count the number of responses returned with **BPERSIST** asserted, allowing it to determine when it has no outstanding persistent operations.

**Example PCMO using write channels**

An example of a CleanSharedPersist transaction on the write channels is shown in Figure A10.2.

In this example, the write is observable to all other agents in the last-level cache, so the Completion response can be sent when the request has been hazarded at that point. The Non-volatile Memory sends a combined Completion and Persist response, so the cache must deassert **BCOMP** when it propagates the response upstream.

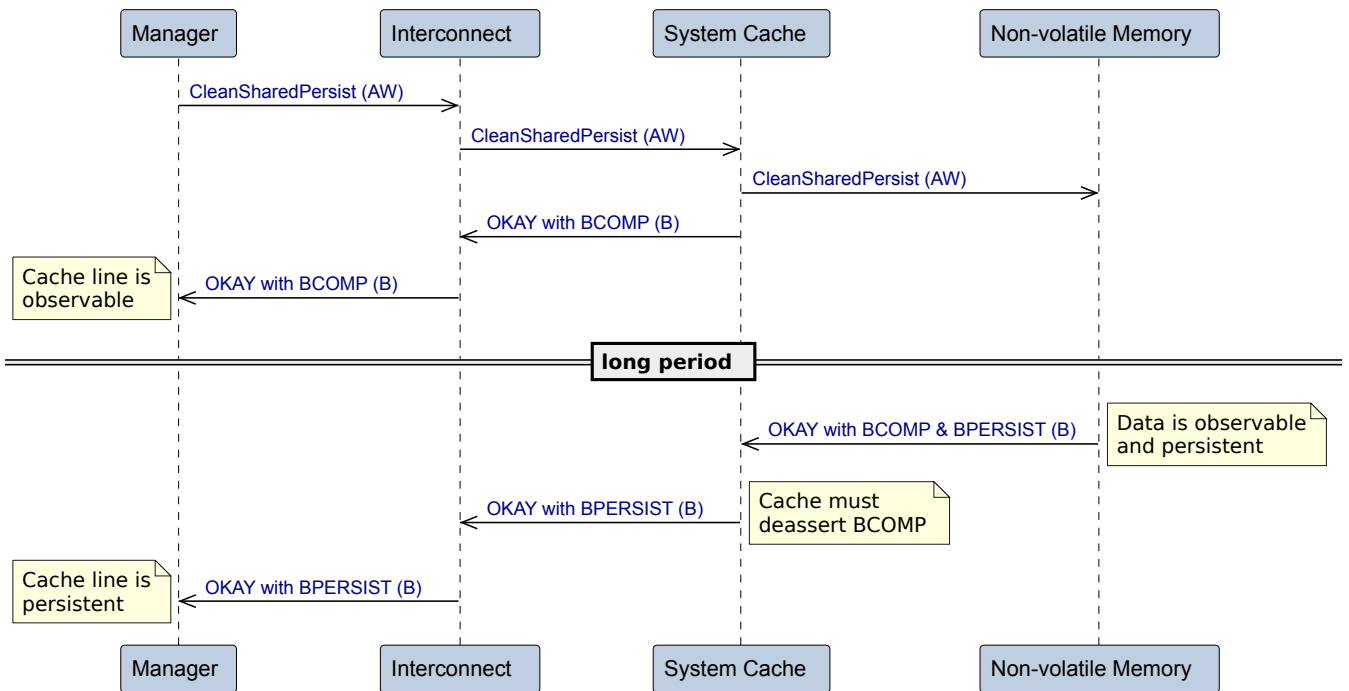

**Figure A10.2: Example PCMO transaction**

**A10.8.5 PCMOs on read channels**

If using read channels to transport cache maintenance operations, only the CleanSharedPersist transaction is supported. CleanSharedDeepPersist can only be used on the write channels.

A CleanSharedPersist is signaled by setting **ARSNOOP** to 0b1010.

When Persist\_CMO is False, **ARSNOOP** must not indicate CleanSharedPersist.

There is a single response transfer on the R channel which indicates that the request is observed, and all cache lines have been cleaned to the PoP.

## A10.9 Cache Maintenance and Realm Management Extension

When using the Realm Management Extensions (RME), it is required that cache maintenance operations apply to all lines with the same address and physical address space as the CMO, irrespective of other attributes. [Table A10.15](#) illustrates which cache lines must be operated on by a CMO with and without RME support. See [A5.5 Memory protection and the Realm Management Extension](#) and [4] for more information.

**Table A10.15: Cache lines operated on by a CMO**

Attribute	RME_Support is False	RME_Support is True
Address	Same cache line	Same cache line
Physical Address Space	Same, using AxCACHE	Same, using {AxCACHE, AxCACHE}
Memory attributes	Any AxCACHE	Any AxCACHE
Shareability Domain	Same Domain	Any Domain

When acted upon by a CleanInvalid or CleanShared CMO, data must propagate to a point where it is observable to all agents using the same physical address space as the CMO.

### A10.9.1 CMO to PoPA

RME defines the Point of Physical Aliasing (PoPA), which is the point in a system where data is observable to accesses from all agents, irrespective of physical address space.

There is a CMO named CleanInvalidPoPA, which helps transitioning ownership of a physical granule from one Security state to another.

The response to a CleanInvalidPoPA indicates that all cached copies are invalidated, and any Dirty cached copy is written past the PoPA.

CleanInvalidPoPA has the same rules as other CMOs, regarding lines that are acted upon and transaction attribute restrictions.

When RME\_Support is True, the **AWCMO** signal is extended to 3b to enable the signaling of a CleanInvalidPoPA, encodings are:

- 0b000: CleanInvalid
- 0b001: CleanShared
- 0b010: CleanSharedPersist
- 0b011: CleanSharedDeepPersist
- 0b100: CleanInvalidPoPA

A CleanInvalidPoPA can be used stand-alone or combined with a write transaction, so can be used with the following values of **AWSNOOP**:

- 0b0110: CMO
- 0b1010: WritePtlCMO
- 0b1011: WriteFullCMO

The CMO\_On\_Write property must be True to use a CleanInvalidPoPA.

The Write\_Plus\_CMO property must be True to use a write with CleanInvalidPoPA.

When using Memory Encryption Contexts, a CleanInvalidPoPA CMO can be used to ensure that data is cleaned and invalidated in all caches upstream of the Point of Encryption. See [A5.6 Memory Encryption Contexts](#) for more information.

## A10.9.2 CMO to PoPA propagation

An optional input signal, **BROADCASTCMOPOPA** can be used to control the propagation of CleanInvalidPoPA at reset-time.

**Table A10.16: BROADCASTCMOPOPA signal**

Name	Width	Default	Description
BROADCASTCMOPOPA	1	0b1	Manager tie-off input, used to control the issuing of a CleanInvalidPoPA CMO.

When **BROADCASTCMOPOPA** is present and deasserted, then CleanInvalidPoPA is converted to CleanInvalid. This applies to standalone CMOs and write with CMOs.

Note that the issuing of the CleanInvalid is controlled by the **BROADCASTSHAREABLE** and **BROADCASTCACHEMAINT** signals.

## A10.10 Processor cache maintenance instructions

The cache maintenance protocol requires that the cache maintenance operations use the **AxCACHE** and **AxDOMAIN** signals to identify the caches on which the cache maintenance operations must operate.

For a processor that has cache maintenance instructions that are required to operate on a different number of caches than are defined by the **AxCACHE** and **AxDOMAIN** values, the cacheability and shareability of the transaction must be adapted to meet the requirements of the processor.

For example, if a processor instruction performing a cache maintenance operation on a location with Device memory attributes is required to operate on all caches within the system, then the Manager must issue a cache maintenance transaction as Normal Cacheable, Shareable, since this is the most pervasive of the cache maintenance operations and operates on all the required caches.

### A10.10.1 Unpredictable behavior with software cache maintenance

Cache maintenance can be used to reliably communicate shared memory data structures between a coherent group of Managers and non-coherent agents. This process must follow a particular sequence to reliably make the data structures visible as required.

When using cache maintenance to make the writes of a non-coherent agent visible to a coherent group of Managers, there are periods of time when writing and reading the data structures gives UNPREDICTABLE results and can cause a loss of coherency.

The observation of a line that is being updated by a non-coherent agent is UNPREDICTABLE during the period between the clean transaction that starts the sequence and the invalidate transaction that completes it. During this period, it is permissible to see multiple transitions of a cache line that is being updated by a non-coherent agent.

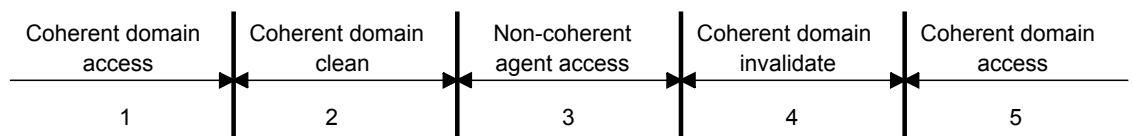

**Figure A10.3: Required sequence of communication between coherent and non-coherent domains**

There are five stages of communication between a coherent domain and a non-coherent agent, shown in [Figure A10.3](#). The five-stage sequence is:

1. The coherent domain has access. The coherent domain has full read and write access to the appropriate memory locations during this stage. This stage finishes when all required writes from the coherent domain are complete within the coherent domain.
2. The coherent domain is cleaned. A cache clean operation is required for all the address locations that are undergoing software cache maintenance during this stage. The coherent domain clean forces all previous writes to be visible to the non-coherent agent. This stage finishes when all required writes are complete and therefore visible to the non-coherent agent.
3. The non-coherent agent has access. The non-coherent agent has both read and write access to the defined memory locations during this stage. This stage finishes when all required writes from the non-coherent agent are complete.
4. The coherent domain is invalidated. A cache invalidate operation is required for all the address locations that are undergoing software cache maintenance during this stage. This coherent domain invalidate stage removes all cached copies of the defined locations ensuring that any subsequent access from the coherent domain observes the writes from the non-coherent agent. This stage finishes when all the required invalidations are complete.

5. The coherent domain has full access to the defined memory locations.

The following table shows when accesses from the coherent domain or the non-coherent agent are permitted. The remaining accesses can have UNPREDICTABLE results, with possible loss of coherency.

**Table A10.17: Permitted accesses from the Coherent domain and Non-coherent agent**

Phase	Description	Coherent domain		External agent	
		Read	Write	Read	Write
1	Coherent domain access	Permitted	Permitted	–	–
2	Coherent domain clean	–	–	–	–
3	External agent access	–	–	Permitted	Permitted
4	Coherent domain invalidate	–	–	–	–
5	Coherent domain access	Permitted	Permitted	–	–

## Chapter A11

# Additional request qualifiers

This chapter describes some additional request qualifiers for the AXI protocol.

It contains the following sections:

- [A11.1 Non-secure Access Identifiers \(NSAID\)](#)
- [A11.2 Page-based Hardware Attributes \(PBHA\)](#)
- [A11.3 Subsystem Identifier](#)

## A11.1 Non-secure Access Identifiers (NSAID)

To support the storage and processing of protected data, a set of signals can be added that enable access to particular Non-secure memory locations to be controlled. The signals supply a Non-secure Access Identifier (NSAID) alongside the transaction request. The NSAID can be checked to permit or deny access to a memory location.

The NSAccess\_Identifiers property is used to indicate whether a component supports these additional signals.

**Table A11.1: NSAccess\_Identifiers property**

NSAccess_Identifiers	Default	Description
True		NSAID signaling is present on the interface.
False	Y	NSAID signaling is not present on the interface.

### A11.1.1 NSAID signaling

If the NSAccess\_Identifiers property is True, the following signals are added to the read and write request channels.

**Table A11.2: AxNSAID signals**

Name	Width	Default	Description
AWNSAID, ARNSAID	4	0x0	Non-secure access identifier, can be checked to permit or deny access to a memory location.

A 4-bit NSAID value supports up to 16 unique identifiers. For each NSAID, there is a set of access permission that is defined which determine how locations in memory are permitted to be accessed. The access permissions can be:

- No access
- Read-only access
- Write-only access
- Read/write access

The mechanism that is used to define the access permissions for each NSAID is IMPLEMENTATION DEFINED. However, this mechanism is typically implemented using some form of *Memory Protection Unit* (MPU).

The following rules and recommendations apply to NSAID values:

- Requests to Secure, Root, or Realm address spaces must use an NSAID value of zero.
- Requests to the Non-secure physical address space can use any NSAID value.
- It is permitted for transactions with different NSAID values to have access to overlapping memory locations.
- It is permitted for transactions with different NSAID values to have any combination of access permissions for a given memory location.
- It is recommended that Managers use the default NSAID value of zero when accessing data that is not protected, or when they do not have an assigned NSAID value.
- If a Manager is required to use a single NSAID value, then it is permitted for NSAID signals to be tied to a fixed value.



### A11.1.2 Caching and NSAID

Where caching and system coherency is performed upstream of permission checking, accesses with different NSAID values that pass data between them must be subjected to permission checks.

The rules that are associated with NSAID use and coherency are as follows:

- When an agent caches a line of data that has been fetched using a particular NSAID value, it must ensure that any subsequent write to main memory or any response to a snoop uses the same NSAID value. This rule ensures that a Manager cannot move a cache line of data from one protected region to another.
- For a read request with a given NSAID value, if a snoop is used to obtain the data:
  - If the NSAID value of the snoop response matches the read request, then data can be provided directly.
  - If the NSAID value of the snoop response does not match the read request, then the cache line must first be written to memory using the NSAID value obtained through the snoop response, and then read from memory using the NSAID value of the original request. The write and subsequent read are only required to reach a point at which permission checking has occurred.
- Snoop transactions that invalidate cached copies, such as `MakeInvalid`, must not be used if memory protection is used. All such snoop transactions must be replaced with transactions that also clean the cache line to main memory, such as `CleanInvalid`.
- Any interconnect-generated write to main memory that occurs as the result of a snoop must use the NSAID value that is obtained from the snoop response.
- If a single Manager can issue transactions with multiple NSAID values, it must ensure that internal accesses to cached copies use the NSAID value that was used to fetch the cache line initially:
  - An access that has a cache line hit with the same address, but a different NSAID value, must clean and invalidate the cache line before refetching the cache line with the appropriate NSAID value. This process ensures that a protection check is performed.
  - If it is guaranteed that the Manager never accesses the same cache line with a different NSAID value, clean and invalidation operations are not necessary. This guarantee can be by design or be assured by using appropriate cache maintenance operations.
- Appropriate cache maintenance must be performed when changing the access permissions for NSAID values.

It is permitted for a Manager to write to a cache line when that agent does not have write permission to the location. It is also permitted for the updated cache line to be passed to other Managers using the same NSAID value. However, it is not permitted for the update to propagate to main memory or to an access using a different NSAID value.

## A11.2 Page-based Hardware Attributes (PBHA)

Page-based hardware attributes (PBHA) are 4-bit descriptors associated with a translation table entry that can be annotated onto a transaction request.

This specification describes how they can be transported but their use is IMPLEMENTATION DEFINED.

The following signals are used on the read and write request channels to transfer PBHA values.

**Table A11.3: AxPBHA signals**

Name	Width	Default	Description
AWPBHA, ARPBHA	4	-	A 4b user-defined descriptor associated with a translation table entry that can be annotated onto a transaction request.

The PBHA\_Support property is used to indicate whether an interface supports PBHA.

**Table A11.4: PBHA\_Support property**

PBHA_Support	Default	Description
True		PBHA is supported. AWPBHA and ARPBHA are present on the interface.
False	Y	PBHA is not supported.

### A11.2.1 PBHA values

PBHA values can be added to the request during address translation and propagated through a system if they are supported by downstream components. At the MMU, all transactions to the same page and physical address space are likely to have the same value but accuracy of PBHA values might be degraded as they pass through the system.

Examples of where PBHA values might become inaccurate are:

- When an interconnect is combining transactions from different sources, some might have PBHA values attached, and others might take a fixed value.
- In a downstream cache, PBHA values might not be cached along with the data in all cases.
- In the case that PBHA values in translation tables are changed, values on in-flight transactions or cached data could become inconsistent. Appropriate TLB Invalidate or cache maintenance operations could be used to achieve a consistency.

This list is not exhaustive, designers are encouraged to document situations where PBHA can become inaccurate within their component. A system integrator wanting to use PBHA must consider every component between the source and target to determine the requirements of the target can be met.

## A11.3 Subsystem Identifier

The Subsystem Identifier (ID) is a field that can be added to transaction requests to indicate from which subsystem they originate. The Subsystem ID can be used to qualify the transaction address and provide isolation between parts of a system when they share memory or devices.

The signals used to transfer the Subsystem ID are shown in [Table A11.5](#).

**Table A11.5: AxSUBSYSID signals**

Name	Width	Default	Description
AWSUBSYSID, ARSUBSYSID	SUBSYSID_WIDTH	-	Subsystem identifier that indicates from which subsystem a request originates.

The SUBSYSID\_WIDTH property is used to define the width and presence of the Subsystem ID signals. If the property is zero, the signals are not present.

Name	Values	Default	Description
SUBSYSID_WIDTH	0..8	0	Width of AWSUBSYSID and ARSUBSYSID in bits.

### A11.3.1 Subsystem ID usage

This specification does not define the usage of Subsystem IDs.

Example implementations include:

- A Manager or group of Managers using a single Subsystem ID where they have common access rights to shared memory or peripherals.
- An interconnect combining requests from Managers in different subsystems. In this case, the interconnect Manager interface therefore uses different Subsystem IDs for different requests.
- Using the Subsystem ID as a look-up in a firewall or Memory Protection Unit (MPU) to isolate subsystems for safety or security reasons.
- Requiring that all Managers within a coherent domain use the same Subsystem ID, so it can be used in snoop filtering.
- Using Subsystem ID for performance profiling or monitoring.
- An interconnect that propagates Subsystem ID through some interfaces and not others.

## Chapter A12

# Other write transactions

This chapter describes additional write transactions supported in the AXI protocol.

It contains the following sections:

- [A12.1 WriteZero Transaction](#)
- [A12.2 WriteDeferrable Transaction](#)

## A12.1 WriteZero Transaction

Many writes in a system, particularly from a CPU, have data set to zero. For example, while initializing or allocating memory. These writes with a zero value consume write data bandwidth and interconnect power that can be saved by using a data-less request.

The WriteZero transaction is used to write zero values to a cache line sized data location. The transaction consists of a write request and write response but has no associated write data transfer. It is functionally equivalent to a regular write to the same location with fully populated data lanes where all data has a value of zero.

The WriteZero\_Transaction property is used to indicate whether an interface supports the WriteZero transaction.

**Table A12.1: WriteZero\_Transaction property**

WriteZero_Transaction	Default	Description
True		WriteZero is supported.
False	Y	WriteZero is not supported.

The rules for a WriteZero transaction are:

- A WriteZero request indicates that the data at the locations indicated by address, size, and length attributes must be set to zero.
- A WriteZero transaction consists of a request on the AW channel and a single response on the B channel.
- A WriteZero transaction is cache line sized and Regular, see [A4.1.8 Regular transactions](#)
- **AWSNOOP** must be 0b01111 or 0b00111.
- **AWLOCK** must be 0b0, not exclusive access.
- **AWTAGOP** must be Invalid.
- **AWID** must be unique-in-flight, which means:
  - A WriteZero transaction can only be issued if there are no outstanding write transactions using the same **AWID** value.
  - A Manager must not issue a request on the write channel with the same **AWID** as an outstanding WriteZero transaction.
  - If present, **AWIDUNQ** must be asserted for a WriteZero transaction.
- **AWDOMAIN** can take any value. If the Domain is Shareable, a WriteZero acts as a WriteUniqueFull with zero as data.
- A Manager that issues WriteZero requests cannot be connected to a Subordinate that does not support WriteZero.

## A12.2 WriteDeferrable Transaction

In enterprise systems, accelerators are commonly used that are accessed across chip-to-chip connections using a 64-byte atomic store operation. These store operations are performed to shared queues within the accelerator. In some cases, it is possible that the store will not be accepted because the queue is full but might be accepted if retried later. This type of transaction is known as a WriteDeferrable.

PCIe Gen5 includes support for a deferrable write through the Deferrable Memory Write (DMWr) transaction. This requires a write response, so the DMWr is a non-posted Write. It is expected that a WriteDeferrable transaction in AXI translates to a PCIe DMWr transaction.

### A12.2.1 WriteDeferrable transaction support

The WriteDeferrable\_Transaction property is used to indicate whether an interface supports the WriteDeferrable transaction.

**Table A12.2: WriteDeferrable\_Transaction property**

WriteDeferrable_Transaction	Default	Description
True		WriteDeferrable is supported.
False	Y	WriteDeferrable is not supported.

A Manager that issues WriteDeferrable requests cannot be connected to a Subordinate that does not support WriteDeferrable.

### A12.2.2 WriteDeferrable signaling

When the WriteDeferrable\_Transaction property is True, **AWSNOOP** and **BRESP** must be wide enough to accommodate additional encodings:

- **AWSNOOP\_WIDTH** must be 5.
- **BRESP\_WIDTH** must be 3.

A WriteDeferrable transaction consists of a request, 64-bytes of write data and a write response.

The rules for a WriteDeferrable transaction are:

- **AWSNOOP** is 0b10000.
- **AWDOMAIN** is 0b11 (System shareable).
- **AWCACHE** is Device or Normal Non-cacheable.
- Legal combinations of Length x Size are:
  - 1 x 64-bytes
  - 2 x 32-bytes
  - 4 x 16-bytes
  - 8 x 8-bytes
  - 16 x 4-bytes
- All bits of **WSTRB** must be set within the 64-byte container.

- **AWADDR** is aligned to 64-bytes.
- **AWBURST** is INCR.
- **AWLOCK** is deasserted, not exclusive access.
- **AWATOP** is Non-atomic transaction.
- **AWTAGOP** is Invalid.
- The ID is unique-in-flight for all transactions, which means:
  - A WriteDeferrable transaction can only be issued if there are no outstanding transactions on the write channels with the same ID value.
  - A Manager must not issue a request on the write channels with the same ID as an outstanding WriteDeferrable transaction.
  - If present, **AWIDUNQ** must be asserted for a WriteDeferrable transaction.
- A WriteDeferrable transaction must be treated as 64-byte atomic, therefore:
  - It must only be to locations which have a single-copy atomicity size of 64-bytes or greater.
  - The request must not be split or merged with other transactions.

### A12.2.3 Response to a WriteDeferrable request

The following table shows the meanings for the response to a WriteDeferrable request.

<b>BRESP[2:0]</b>	<b>Response</b>	<b>Indication</b>
0b000	OKAY	The write was accepted by a Subordinate that supports WriteDeferrable transactions and was successful.
0b001	EXOKAY	Not a permitted response to WriteDeferrable.
0b010	SLVERR	Write has reached an end point but has been unsuccessful.
0b011	DECERR	Write has not reached a point where data can be written.
0b100	DEFER	Write was unsuccessful because it cannot be serviced at this time but might be successful if resent later. The location is not updated. This response is only permitted for a WriteDeferrable transaction.
0b101	TRANSFAULT	Write was terminated because of a translation fault which might be resolved by a PRI request.
0b110	RESERVED	–
0b111	UNSUPPORTED	Write was unsuccessful because the transaction type is not supported by the target. The location is not updated. This response is only permitted for a WriteDeferrable transaction.

If an interconnect detects that a WriteDeferrable is targeting a Subordinate that does not support WriteDeferrable transactions, it must not propagate the request.

In this case, it is expected that an UNSUPPORTED response is sent, but SLVERR or DECERR are also permitted.

A Subordinate interface that can recognize a WriteDeferrable but cannot process it, has the WriteDeferrable\_Transaction property True but is expected to respond with UNSUPPORTED.

## Chapter A13

# System monitoring, debug, and user extensions

This chapter describes the AXI features for system monitoring and debug. It also describes how to add user-defined extensions to each channel.

It contains the following sections:

- [A13.1 Memory System Resource Partitioning and Monitoring \(MPAM\)](#)
- [A13.2 Memory Tagging Extension \(MTE\)](#)
- [A13.3 Trace signals](#)
- [A13.4 User Loopback signaling](#)
- [A13.5 User defined signaling](#)



## A13.1 Memory System Resource Partitioning and Monitoring (MPAM)

Memory System Resource Partitioning and Monitoring (MPAM) is a technology for partitioning and monitoring memory system resources for physical and virtual machines. The full MPAM architecture is described in the Armv8.4 extensions [6].

Each MPAM-enabled Manager adds MPAM information to its requests. The MPAM information is propagated through the system to memory components where it can be used to influence resource allocation decisions. Monitoring memory usage based on MPAM information can also enable the tuning of performance and accurate costing between machines.

### A13.1.1 MPAM signaling

The MPAM\_Support property as shown in [Table A13.1](#) is used to indicate whether an interface supports MPAM.

**Table A13.1: MPAM\_Support property**

MPAM_Support	Default	Description
MPAM_12_1		The interface is enabled for MPAM and includes the MPAM signals on AW and AR channels. The width of PARTID is 12 and PMG is 1.
MPAM_9_1		The interface is enabled for MPAM and includes the MPAM signals on AW and AR channels. The width of PARTID is 9 and PMG is 1.
False	Y	MPAM is not supported, the interface is not MPAM enabled and no MPAM signals are present on the interface.

The signals used to support MPAM are shown in [Table A13.2](#).

**Table A13.2: AxMPAM signals**

Name	Width	Default	Description
AWMPAM, ARMPAM	MPAM_WIDTH	-	Memory System Resource Partitioning and Monitoring (MPAM) information for a request.

The MPAM information has three fields. The mapping of bits to fields depends on whether RME is supported on the interface. For more information on RME, see [A5.5 Memory protection and the Realm Management Extension](#).

The value of MPAM\_WIDTH is determined by the MPAM\_Support and RME\_Support properties.

When MPAM\_Support is False, MPAM\_WIDTH must be zero.

### A13.1.2 MPAM fields

MPAM fields are encoded within the **AxMPAM** signals depending on the **MPAM\_Support** and **RME\_Support** properties.

When **MPAM\_Support** is **MPAM\_9\_1** and **RME\_Support** is **False**, **MPAM\_WIDTH** must be 11 and the mapping is shown in [Table A13.3](#).

**Table A13.3: MPAM\_9\_1 fields when RME\_Support is False**

Field	Description	Width	Mapping
MPAM_NS	Security indicator	1	AxMPAM[0]
PARTID	Partition identifier	9	AxMPAM[9:1]
PMG	Performance monitor group	1	AxMPAM[10]

When **MPAM\_Support** is **MPAM\_9\_1** and **RME\_Support** is **True**, **MPAM\_WIDTH** must be 12 and the mapping is shown in [Table A13.4](#).

**Table A13.4: MPAM\_9\_1 fields when RME\_Support is True**

Field	Description	Width	Mapping
MPAM_SP	Physical address space indicator	2	AxMPAM[1:0]
PARTID	Partition identifier	9	AxMPAM[10:2]
PMG	Performance monitor group	1	AxMPAM[11]

When **MPAM\_Support** is **MPAM\_12\_1** and **RME\_Support** is **False**, **MPAM\_WIDTH** must be 14 and the mapping is shown in [Table A13.5](#).

**Table A13.5: MPAM\_12\_1 fields when RME\_Support is False**

Field	Description	Width	Mapping
MPAM_NS	Security indicator	1	AxMPAM[0]
PARTID	Partition identifier	12	AxMPAM[12:1]
PMG	Performance monitor group	1	AxMPAM[13]

When **MPAM\_Support** is **MPAM\_12\_1** and **RME\_Support** is **True**, **MPAM\_WIDTH** must be 15 and the mapping is shown in [Table A13.6](#).

**Table A13.6: MPAM\_12\_1 fields when RME\_Support is True**

Field	Description	Width	Mapping
MPAM_SP	Physical address space indicator	2	AxMPAM[1:0]
PARTID	Partition identifier	12	AxMPAM[13:2]
PMG	Performance monitor group	1	AxMPAM[14]

### A13.1.3 MPAM component interactions

Implementation of MPAM technology has impacts on Manager, Interconnect, and Subordinate components.

If a Manager component is included in an MPAM-enabled system, but does not support MPAM signaling, then the system must add the MPAM information. The default is IMPLEMENTATION DEFINED, but one option is to copy the physical address space (**AxNSE**, **AxPROT[1]**) of the request onto the least significant MPAM bits and zero-extend the higher bits.

#### **Manager components**

Manager components that are MPAM-enabled must drive MPAM signals when the corresponding **AxVALID** is asserted. Values used are IMPLEMENTATION DEFINED for all transaction types. It is expected, but not required, that a Manager uses the same sets of values for read and write requests. A Manager might not use all the PARTID or PMG values that can be signaled on the interface.

#### **Interconnect components**

MPAM identifiers have global scope. There is no requirement for interconnect components to make MPAM identifiers unique. When an interconnect Manager interface is connected to an MPAM-enabled Subordinate, it can use propagated values or IMPLEMENTATION DEFINED values.

#### **Subordinate components**

A Subordinate component that is MPAM-enabled can use the MPAM information for memory partitioning and monitoring. MPAM signals are sampled when the corresponding **AxVALID** is asserted.

## A13.2 Memory Tagging Extension (MTE)

The Memory Tagging Extension (MTE) provides a mechanism that can be used to detect memory safety violations.

When a region of memory is allocated for a particular use, it is given an Allocation Tag value. When the memory is subsequently accessed, a Physical Tag value is provided that corresponds to the physical address of the access. If the Physical Tag does not match with the Allocation Tag, a warning is generated.

Allocation Tags are stored in the memory system and can be cached in the same way as data. Each tag is 4 bits and is associated with a 16-byte aligned address location.

The following operations are supported:

- Updating the Allocation Tag value using a write transaction, with or without updating the associated data value.
- Reading of data with associated Allocation tag. The Requestor can then perform the check of Physical Tag against the Allocation Tag.
- Writing to memory with a Physical Tag to be compared with the Allocation Tag. The result is indicated in the transaction response.

When memory tagging is supported in a system, it is not required that every transaction uses memory tagging. It is also not required that every component in the system supports memory tagging.

The Memory Tagging Extension is supported on Arm A-profile architecture v8.5 onwards and is described in the *Arm® Architecture Reference Manual for A-profile architecture* [3].

### A13.2.1 MTE support

The MTE\_Support property of an interface is used to indicate the level of support for MTE. There are different levels of support that can be used, depending on the use-case.

**Table A13.7: MTE\_Support property**

MTE_Support	Default	Description
Standard		Memory tagging is fully supported on the interface, all MTE signals are present.
Simplified		Memory tagging is supported except the MTE Match operation. Partial tag writes are not permitted, so when AWTAGOP is Update, all WTAGUPDATE bits that correspond to the tags inside the transaction container must be asserted. BTAGMATCH is not present. BCOMP is not required.
Basic		Memory tagging is supported on the interface at a basic level. A limited set of tag operations are permitted. BTAGMATCH is not present. BCOMP is not required.
False	Y	Memory tagging is not supported on the interface and no MTE signals are present.

Note that MTE\_Support must be False on interfaces with a data width smaller than 32 bits.

The compatibility between Manager and Subordinate interfaces, according to the values of the MTE\_Support property is shown in [Table A13.8](#).

**Table A13.8: MTE\_Support**

	<b>Subordinate: False</b>	<b>Subordinate: Basic</b>	<b>Subordinate: Simplified</b>	<b>Subordinate: Standard</b>
<b>Manager: False</b>	Compatible.	Compatible.	Compatible.	Compatible.
<b>Manager: Basic</b>	Protocol compliant. The Subordinate ignores <b>AxTAGOP</b> , so write tags are lost and read tag values are static.	Compatible.	Compatible.	Compatible.
<b>Manager: Simplified</b>	Protocol compliant. The Subordinate ignores <b>AxTAGOP</b> , so write tags are lost and read tag values are static.	Not compatible.	Compatible.	Compatible.
<b>Manager: Standard</b>	Not compatible.	Not compatible.	Not compatible.	Compatible.

### A13.2.2 MTE signaling

The signals required to support MTE are shown in [Table A13.9](#).

**Table A13.9: MTE signals**

<b>Name</b>	<b>Width</b>	<b>Default</b>	<b>Description</b>
AWTAGOP	2	0b00 (Invalid)	Indicates if MTE tags are associated with a write transaction.
ARTAGOP	2	0b00 (Invalid)	Indicates if MTE tags are requested with a read transaction.
WTAG, RTAG	ceil(DATA_WIDTH/128)*4	-	Memory tag associated with data. There is a 4-bit tag per 128-bits of data, with a minimum of 4-bits. Has the same validity rules as the associated data. It is recommended that invalid tags are driven to zero.
WTAGUPDATE	ceil(DATA_WIDTH/128)	-	Indicates which tags must be written to memory when AWTAGOP is Update. There is 1 bit per 4 bits of tag.
BTAGMATCH	2	-	Indicates the result of a tag comparison on a write transaction.
BCOMP	1	0b1	Asserted HIGH to indicate a Completion response.

### A13.2.3 Caching tags

Allocation Tags that are cached must be kept hardware-coherent. The coherence mechanism is the same as for data. Applicable tag cache states are: Invalid, Clean, and Dirty. A line that is either Clean or Dirty is Valid.

Constraints on the combination of data cache state and tag cache state are:

- Tags can be Valid only when data is Valid.
- Tags can be Invalid when data is Valid.
- When a cached line is evicted and tags are Dirty, then it is permitted to treat clean data that is evicted as dirty.
- When Dirty tags are evicted from a cache, they must be either written back to memory or passed dirty to another cache.
- When Clean tags are evicted from a cache, they can be sent to other caches or dropped silently.
- A CMO which hits a line with Valid tags applies to the data and the tag.
- When a MakeInvalid or ROMI transaction hits a line with dirty tags, the tags must be written back to memory.

### A13.2.4 Transporting tags

Tag values are transported using the **WTAG** signal when **AWTAGOP** is not Invalid.

Tag values are transported using the **RTAG** signal when **ARTAGOP** is not Invalid.

When transporting tags, the following rules apply in addition to other constraints based on the transaction type:

- The transaction must be cache-line-sized or smaller and not cross a cache line boundary.
- **AxBURST** must be INCR or WRAP, not FIXED.
- The transaction must be to Normal Write-Back memory, which means:
  - The **CACHE\_Present** property must be True.
  - **AxCACHE[3:2]** is not 0b00.
  - **AxCACHE[1:0]** is 0b11.
- The ID value must be unique-in-flight, which means:
  - A read with tag Transfer or Fetch can only be issued if there are no outstanding read transactions using the same **ARID** value.
  - A Manager must not issue a request on the read channel with the same **ARID** as an outstanding read with tag Transfer or Fetch.
  - If present, **ARIDUNQ** must be asserted for a read with tag Transfer or Fetch.
  - A write with tag Transfer, Update or Match can only be issued if there are no outstanding write transactions using the same **AWID** value.
  - A Manager must not issue a request on the write channel with the same **AWID** as an outstanding write with tag Transfer, Update, or Match.
  - If present, **AWIDUNQ** must be asserted for a write with tag operations Transfer, Update, or Match.
- The memory tag is transported on **RTAG** or **WTAG**, where **TAG[4n-1:4(n-1)]** corresponds to **DATA[128n-1:128(n-1)]**.
- For data widths wider than 128 bits, the tag signal carries multiple tags. The tags are driven appropriate to the data being transported, with the least significant tag bits used to transport the tag for the least significant 128 bits of data.
- For read transactions that use read data chunking, only tags which correspond to valid chunk strobes are required to be valid.

- For write transactions where multiple transfers address the same tag, **WTAG** and **WTAGUPDATE** values must be consistent for each 4-bit tag that is accessed by the transaction.

### A13.2.5 Reads with tags

A read can request that Allocation Tags are returned along with data, which is determined by the value of **ARTAGOP**, as shown in [Table A13.10](#).

**Table A13.10: ARTAGOP encodings**

<b>ARTAGOP</b>	<b>Operation</b>	<b>Meaning</b>
0b00	Invalid	Tags are not required to be returned with the data. In the response to this request, RTAG is invalid and must be zero.
0b01	Transfer	Each transfer of read data must have a valid tag value. Tags must be sent for every 16-byte granule that is accessed, even if the address is not aligned to 16 bytes.
0b10	RESERVED	-
0b11	Fetch	Only tags are required to be fetched. Data is not required to be valid and must not be used by the Manager. Transactions using Fetch must be cache line sized and Regular. Tags must be sent for every 16-byte granule that is accessed.

There are limitations on which read channel Opcodes can be used with MTE tag transfer. [Table A13.11](#) shows the combinations of Opcode and TagOp that are legal for each configuration of MTE\_Support.

A TagOp encoding of Invalid is legal for all Opcodes.

An asterisk (\*) indicates all variants of the Opcode.

**Table A13.11: Legal tag operations for read transactions**

<b>Opcode</b>	<b>MTE_Support = Basic</b>		<b>MTE_Support = Simplified</b>		<b>MTE_Support = Standard</b>	
	<b>Transfer</b>	<b>Fetch</b>	<b>Transfer</b>	<b>Fetch</b>	<b>Transfer</b>	<b>Fetch</b>
ReadNoSnoop	Y	-	Y	Y	Y	Y
ReadOnce	Y	-	Y	-	Y	-
ReadShared	Y	-	Y	-	Y	-
ReadClean	Y	-	Y	-	Y	-
ReadOnceCleanInvalid	-	-	-	-	-	-
ReadOnceMakeInvalid	-	-	-	-	-	-
CleanInvalid*	-	-	-	-	-	-
CleanShared*	-	-	-	-	-	-
MakeInvalid	-	-	-	-	-	-
DVM Complete	-	-	-	-	-	-

### A13.2.6 Writes with tags

A write can request that Allocation Tags are written along with data or that the write includes a Physical Tag which is compared with the Allocation Tag already stored in memory. The signal **AWTAGOP** indicates the tag operation to be performed.

**Table A13.12: AWTAGOP encodings**

<b>AWTAGOP</b>	<b>Operation</b>	<b>Meaning</b>
0b00	Invalid	The tags are not valid; no tag updating or checking is required. WTAGUPDATE must be deasserted. WTAG must be zero.
0b01	Transfer	The tags are Clean. Tag check does not need to be performed. The completer of the write can cache the tags if it is allocating the data. WTAGUPDATE must be deasserted. WTAG bits must be valid for every byte in the transaction container.
0b10	Update	Tag values have been updated and are dirty; the tags in memory must be updated, according to WTAGUPDATE. WTAGUPDATE can have any number of bits asserted, including none. Tags that are only partially addressed in the transaction must have WTAGUPDATE deasserted. Write*Full* Opcodes must have all associated WTAGUPDATE bits asserted. WTAG must be valid for every associated WTAGUPDATE bit that is asserted.
0b11	Match	The tags in the write must be checked against the Allocation Tag values that are obtained from memory. The Match operation must be performed for all tags where any corresponding write data strobes are asserted. It is required to update memory with the data, even if the match fails. WTAGUPDATE must be deasserted. WTAG bits must be valid for byte lanes that are enabled by WSTRB. For interfaces with more than 4 bits of tags, the Match operation is performed only on those tags that correspond to active byte lanes.

For a write with tag Update, **WTAGUPDATE** indicates which tags must be written. It has the following rules:

- **WTAGUPDATE[n]** corresponds to **WTAG[4n+3:4n]**.
- If a bit is asserted, then the corresponding tags must be written to memory.
- If a bit is deasserted, then the corresponding tags are invalid.
- **WTAGUPDATE** bits outside of the transaction container must be deasserted.
- For operations other than Update, **WTAGUPDATE** must be deasserted.
- A tag-only write can be achieved by asserting **WTAGUPDATE** and deasserting **WSTRB**.



There are limitations on which write channel Opcodes can be used with MTE tag transfer. Table A13.13 shows the combinations of Opcode and TagOp that are legal for each configuration of MTE\_Support.

A TagOp encoding of Invalid is legal for all Opcodes.

An asterisk (\*) indicates all variants of the Opcode.

**Table A13.13: Legal tag operations for write transactions**

Opcode	MTE_Support = Basic			MTE_Support = Simplified			MTE_Support = Standard		
	Transfer	Update	Match	Transfer	Update <sup>1</sup>	Match	Transfer	Update	Match
WriteNoSnoop	-	Y	-	-	Y	-	Y	Y	Y <sup>2</sup>
WriteUnique*	-	Y	-	-	Y	-	-	Y	-
WriteNoSnoopFull	-	Y	-	Y	Y	-	Y	Y	Y
WriteBackFull	-	Y	-	Y	Y	-	Y	Y	-
WriteEvictFull	Y	-	-	Y	-	-	Y	-	-
Atomic	-	-	-	-	-	-	-	-	Y
CMO	-	-	-	-	-	-	-	-	-
Write*CMO	-	-	-	Y <sup>3</sup>	Y	-	Y <sup>3</sup>	Y	-
WriteZero	-	-	-	-	-	-	-	-	-
WriteUnique*Stash	-	-	-	-	-	-	-	-	-
StashOnce*	-	-	-	-	-	-	-	-	-
StashTranslation	-	-	-	-	-	-	-	-	-
Prefetch	-	-	-	Y	-	-	Y	-	-
WriteDeferrable	-	-	-	-	-	-	-	-	-
UnstashTranslation	-	-	-	-	-	-	-	-	-
InvalidateHint	-	-	-	-	-	-	-	-	-

<sup>1</sup> Partial tag updates are not supported.

<sup>2</sup> Not Exclusive write.

<sup>3</sup> Domain must be Non-shareable.

Write transactions with a tag Match operation (**AWTAGOP** is 0b11) have two parts to the response:

- A Completion response, which indicates that the write is observable.
- A Match response, which indicates whether the tag comparison passes or fails.

A two-part response enables components with separate data and tag storage parts to respond independently.

Response transfers can be sent in any order. The two parts can be optionally combined into a single response transfer.

The responses are signaled using **BCOMP** and **BTAGMATCH**. Table A13.14 shows the encodings for **BTAGMATCH**.

**Table A13.14: BTAGMATCH encodings**

<b>BTAGMATCH</b>	<b>Operation</b>	<b>Meaning</b>
0b00	None	No match result because not a match transaction
0b01	Separate	Match result is in a separate response transfer
0b10	Fail	Tags do not match
0b11	Pass	Tags match

### **Completion response**

The Completion response indicates that the write is observable. It has the following rules:

- **BCOMP** must be asserted.
- **BTAGMATCH** must be 0b01 (Match result in separate response).
- **BID** must have the same value as **AWID**.
- If Loopback signaling is supported, **BLOOP** must have the same value as **AWLOOP**.
- **BRESP** can take any value that is legal for the request Opcode.
- The Completion response must follow normal response ordering rules.
- The ID value can be reused when this response is received.

### **Match response**

The Match response indicates the result of the tag comparison on a write.

- If the tags match for every transfer of the entire transaction, then the response is Pass.
- If any tags associated with active write data byte lanes do not match those already stored, then the response is Fail.

A Match response has the following rules:

- **BCOMP** must be deasserted.
- **BTAGMATCH** must be 0b11 (Pass) or 0b10 (Fail).
- **BID** must have the same value as **AWID**.
- **BIDUNQ** can take any value, it is not required to have the same value as **AWIDUNQ**.
- **BLOOP** can take any value, it is not required to have the same value as **AWLOOP**.
- **BRESP** can take any value that is legal for the request Opcode.

- The Match response has no ordering requirements, it can overtake or be overtaken by any other response transfers.

### Combined response

A Subordinate can optionally combine the two responses into a single transfer. The following rules apply:

- **BCOMP** must be asserted.
- **BTAGMATCH** must be 0b11 (Pass) or 0b10 (Fail).
- **BID** must have the same value as **AWID**.
- If Loopback signaling is supported, **BLOOP** must have the same value as **AWLOOP**.
- **BRESP** can take any value that is legal for the request Opcode.
- The combined response must follow normal response ordering rules.
- The ID value can be reused when this response is received.

Possible responses to a Match operation are shown in [Table A13.15](#).

**Table A13.15: Possible responses to a Match operation**

<b>BTAGMATCH</b>	<b>BCOMP</b>	<b>Description</b>
0b00	0b0	Not legal for a response to a request with tag Match.
0b00	0b1	Not legal for a response to a request with tag Match.
0b01	0b0	Not legal.
0b01	0b1	Completion response, part of a two-part response.
0b10	0b0	Match Fail, part of a two-part response.
0b10	0b1	Match Fail or MTE Match not supported, one-part response.
0b11	0b0	Match Pass, part of a two-part response.
0b11	0b1	Match Pass, one-part response.

### A13.2.7 Memory tagging interoperability

When an MTE operation is performed to a memory location that does not support memory tagging, the resultant data must be the same as if a non-MTE operation was performed to that location.

- For a read with Transfer or Fetch, **RTAG** is recommended to be zero.
- For a write with Transfer or Update, the data must be written normally. The tag is discarded.
- For a write with Match, the data must be written normally and a single Combined response is given. **BTAGMATCH** must be 0b10 (Fail).

A Subordinate is expected to give an OKAY response to an MTE operation unless it would have given a different response to an equivalent non-MTE operation.

### A13.2.8 MTE and Atomic transactions

An Atomic transaction to a location that is protected with memory tagging can use a write Match operation. Atomic transactions cannot be used with Transfer or Update operations.

AtomicCompare transactions with Match can be 16 bytes or 32 bytes. If the transaction is 32 bytes, the same tag value must be used for tag bits associated with the compare and swap bytes.

Read data that is returned within an Atomic Transaction does not have valid **RTAG** values, so **RTAG** is recommended to be zero.

### A13.2.9 MTE and Prefetch transactions

A Prefetch transaction with **AWTAGOP** of Transfer indicates that the data should be prefetched with tags if possible. A Prefetch transaction has no write data, so no tag Transfer operation occurs within the transaction.

### A13.2.10 MTE and Poison

Section [A17.1 Data protection using Poison](#) discusses the concept of Poison associated with read and write data. There is no poison signaling directly associated with Allocation Tags. When writing a tag with poisoned data, the stored tag might be marked as poisoned.

The exact mechanism for this is IMPLEMENTATION DEFINED. Implementations might choose to do one of the following, but other implementations are possible.

- Poison associated with the data results in the tag being poisoned. Depending on the granularity of the poison associated with the tag, it may not be possible to clear the poison using the same techniques that would be used to clear poison associated with data.
- Poison associated with the data does not result in the tag being poisoned. This means that a corrupted tag might subsequently be used in an MTE Match operation, which could incorrectly fail. The rate at which this occurs should be significantly lower than the rate at which data corruption occurs.
- A mixture of approaches can be used, depending on the caching or storage structures that are used.

## A13.3 Trace signals

An optional Trace signal can be associated with each channel to support the debugging, tracing, and performance measurement of systems.

The Trace\_Signals property is used to indicate whether a component supports Trace signals.

**Table A13.16: Trace\_Signals property**

Trace_Signals	Default	Description
True		Trace signals are included on all channels.
False	Y	Trace signals are not present.

The Trace signals associated with each channel are shown in [Table A13.17](#). If the Trace\_Signals property is True, then the appropriate Trace signal must be present for all channels that are present.

**Table A13.17: Trace signals**

Name	Width	Default	Description
AWTRACE	1	-	Trace signal associated with the write request channel.
WTRACE	1	-	Trace signal associated with the write data channel.
BTRACE	1	-	Trace signal associated with the write response channel.
ARTRACE	1	-	Trace signal associated with the read request channel.
RTRACE	1	-	Trace signal associated with the read data channel.

The exact use for Trace signals is not detailed in this specification, but it is expected that the use of Trace signaling is coordinated across the system and only one use of the Trace signaling occurs at a given time. Trace signal behavior is IMPLEMENTATION DEFINED, but the following recommendations are given:

- A Manager interface can assert the Trace signal along with the address of a transaction that should be tracked through the system.
- A component that provides a response to a transaction with the Trace signal asserted in the request provides a response with the Trace signal asserted.
- Components that pass-through transactions, preserve the Trace attribute of requests and responses.
- If a downstream component does not support Trace signals, an interconnect can assert Trace on the appropriate transfers.
- A Subordinate that receives a request with **AWTRACE** asserted should assert the **BTRACE** signal alongside the response.
- If an interface includes **BCOMP**, then **BTRACE** can take any value for responses with **BCOMP** deasserted.
- **WTRACE** should be propagated through interconnect components.
- A Subordinate that receives a request with the **ARTRACE** signal asserted should assert the **RTRACE** signal alongside every transfer of the read response.
- For Atomic transactions that require a response on the read channel, the **RTRACE** signal should be asserted if **AWTRACE** was asserted.

## A13.4 User Loopback signaling

User Loopback signaling permits an agent that is issuing requests to store information that is related to the transaction in an indexed table.

The transaction response can then use a fast table index to obtain the required information, rather than requiring a more complex lookup that uses the transaction ID.

The Loopback\_Signals property is used to indicate whether a component supports Loopback signals.

**Table A13.18: Loopback\_Signals property**

Loopback_Signals	Default	Description
True		Loopback signaling is supported.
False	Y	Loopback signaling is not supported.

The Loopback signals associated with each channel are shown in [Table A13.19](#). If the Loopback\_Signals property is True, the appropriate Loopback signals must be present for all channels.

**Table A13.19: Loopback signals**

Name	Width	Default	Description
AWLOOP, BLOOP	LOOP_W_WIDTH	All zeros	A user-defined value that must be reflected from a write request to response transfers.
ARLOOP, RLOOP	LOOP_R_WIDTH	All zeros	A user-defined value that must be reflected from a read request to response and data transfers.

The width of the Loopback signals is determined by the properties shown in [Table A13.20](#). The maximum width is a recommendation.

**Table A13.20: Loopback signal width properties**

Name	Values	Default	Description
LOOP_W_WIDTH	0..8	-	Loop signal width on write channels in bits, applies to AWLOOP and BLOOP.
LOOP_R_WIDTH	0..8	-	Loop signal width on read channels in bits, applies to ARLOOP and RLOOP.

The rules for the Loopback width properties are:

- If LOOP\_W\_WIDTH is 0, **AWLOOP** and **BLOOP** are not present.
- If LOOP\_R\_WIDTH is 0, **ARLOOP** and **RLOOP** are not present.
- If Loopback\_Signals is False, LOOP\_R\_WIDTH and LOOP\_W\_WIDTH must be 0.

The usage rules are:

- The value of **BLOOP** must be identical to the value that was on **AWLOOP**.
- If an interface includes **BCOMP**, then **BLOOP** can take any value for responses with **BCOMP** deasserted.

- The value of **RLOOP** must be identical to the value that was on **ARLOOP** for all read data transfers.
- For Atomic transactions that require a response on the read channel, the value of **RLOOP** must be identical to the value that was presented on **AWLOOP**. This means that the Manager must use loop values that can be signaled on both **AWLOOP** and **RLOOP**.

Loopback values are not required to be unique. Multiple outstanding transactions from the same Manager are permitted to use the same value.

It is not required that the Loopback value is preserved as a transaction progresses through a system. An intermediate component is permitted to store the Loopback value of a request it receives and use its own value for a request that it propagates downstream. When the component receives a response to the downstream transaction, it can retrieve the Loopback value for the original transaction.

## A13.5 User defined signaling

An AXI interface can include a set of user-defined signals, called User signals. The signals can be used to augment information to a transaction, where there is a requirement that is not covered by the existing AMBA specification.

Information can be added to:

- A transaction request
- A transaction response
- Each transfer of read or write data within a transaction

Generally, it is recommended to avoid using User signals. The AXI protocol does not define the functions of these signals, which can lead to interoperability issues if two components use the same User signals in an incompatible manner.

### A13.5.1 Configuration

The presence and width of User signals is specified by the properties in [Table A13.21](#):

**Table A13.21: User signal properties**

Name	Values	Default	Description
USER_REQ_WIDTH	0..128	0	Width of user extensions to a request in bits, applies to AWUSER and ARUSER.
USER_DATA_WIDTH	0..DATA_WIDTH/2	0	Width of user extensions to data in bits, applies to WUSER and RUSER.
USER_RESP_WIDTH	0..16	0	Width of user extensions to responses in bits, applies to BUSER and RUSER.

If a property has a value of zero, then the associated signals are not present on the interface.

The maximum signal widths are for guidance only, to set a reasonable maximum for configurable interfaces.

### A13.5.2 User signals

The user signals that can be added to each channel are shown in [Table A13.22](#).

**Table A13.22: User signals**

Name	Width	Default	Description
AWUSER, ARUSER	USER_REQ_WIDTH	All zeros	User-defined extension to a request.
WUSER	USER_DATA_WIDTH	All zeros	User-defined extension to write data.
BUSER	USER_RESP_WIDTH	All zeros	User-defined extension to a write response.
RUSER	USER_DATA_WIDTH + USER_RESP_WIDTH	All zeros	User-defined extension to read data and response.



### A13.5.3 Usage considerations

Where User signals are implemented:

- It is not required that User signals are supported on all channels.
- The design decision regarding presence and width of User signals is made independently for request, data, and response channels.
- It is not required that values on request User signals are reflected on response User signals.

To assist with data width and protocol conversion, it is recommended that:

- `USER_DATA_WIDTH` is an integer multiple of the width of the data channels in bytes.
- User response bits are the same value for every transfer of a read or write response.
- The lower bits of **RUSER** are used to transport per-transaction response information.
- The upper bits of **RUSER** are used to transport per-transfer read data information.

## Chapter A14

# Untranslated Transactions

This chapter describes how AXI supports the use of virtual addresses and translation stash hints for components upstream of a System Memory Management Unit (SMMU). It contains the following sections:

- [A14.1 \*Introduction to Distributed Virtual Memory\*](#)
- [A14.2 \*Support for untranslated transactions\*](#)
- [A14.3 \*Untranslated transaction signaling\*](#)
- [A14.4 \*Translation identifiers\*](#)
- [A14.5 \*Translation fault flows\*](#)
- [A14.6 \*Untranslated transaction qualifier\*](#)
- [A14.7 \*StashTranslation Opcode\*](#)
- [A14.8 \*UnstashTranslation Opcode\*](#)

## A14.1 Introduction to Distributed Virtual Memory

An example system using Distributed Virtual Memory (DVM) is shown in [Figure A14.1](#).

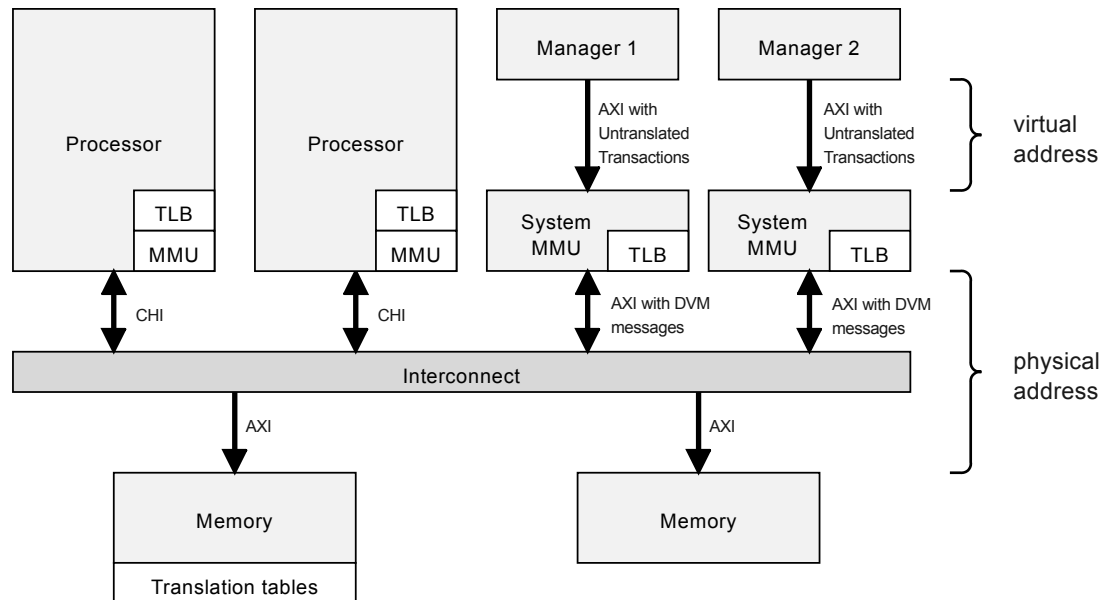

**Figure A14.1: Virtual memory system**

In [Figure A14.1](#), the System Memory Management Units (SMMUs) translate addresses in the virtual address space to addresses in the physical address space. Although all components in the system must use a single physical address space, SMMU components enable different Manager components to operate in their own independent virtual address or intermediate physical address space.

A typical process in the virtual memory system shown in [Figure A14.1](#) might operate as follows:

1. A Manager component operating in a virtual address (VA) space issues a transaction that uses a VA.
2. The SMMU receives the VA for translation to a physical address (PA):
  - If the SMMU has recently performed the requested translation, then it might obtain a cached copy of the translation from its TLB.
  - Otherwise, the SMMU must perform a translation table walk, accessing translation table in memory to obtain the required VA to PA translation.
3. The SMMU uses the PA to issue the transaction for the requesting component.

At step 2 of this process, the translation for the required VA might not exist. In this case, the translation table walk generates a fault, that must be notified to the agent that maintains the translation tables. For the required access to proceed, that agent must then provide the required VA to PA translation. Typically, it updates the translation tables with the required information.

Maintaining the translation tables can require changes to translation table entries that are cached in TLBs. To prevent the use of these entries, a DVM message can be used to issue a TLB invalidate operation.

When the translation tables have been updated, and the required TLB invalidations performed, a DVM Sync transaction is used to ensure that all required transactions have completed.

Details of DVM messages used to maintain SMMUs can be found in [Chapter A15 Distributed Virtual Memory messages](#).

## A14.2 Support for untranslated transactions

AXI supports the use of virtual addresses through the untranslated transactions extension. The specification for untranslated transactions has developed over time and there are currently three different versions. It is recommended that new designs using virtual memory use version 3 of the specification.

The `Untranslated_Transactions` property is used to indicate which version of untranslated transactions is supported by an interface.

**Table A14.1: Untranslated\_Transactions property**

Untranslated_Transactions	Default	Description
v3		Untranslated transactions version 3 is supported.
v2		Untranslated transactions version 2 is supported.
v1		Untranslated transactions version 1 is supported.
True		Untranslated transactions version 1 is supported.
False	Y	Untranslated transactions are not supported.

Address translation is the process of translating an input address to an output address based on address mapping and memory attribute information that is held in translation tables. This process permits agents in the system to use their own virtual address space, but ensures that the addresses for all transactions are eventually translated to a single physical address space for the entire system.

The use of a single physical address space is required for the correct operation of hardware coherency and therefore the SMMU functionality is typically located before a coherent interconnect.

The additional signals that are specified in this section provide sufficient information for an SMMU to determine the translation that is required for a particular transaction and permit different transactions on the same interface to use different translation schemes.

All signals in the Untranslated Transactions extension are prefixed with **AWMMU** for write transactions and **ARMMU** for read transactions.

In this specification, **AxMMU** indicates **AWMMU** or **ARMMU**.

## A14.3 Untranslated transaction signaling

The signals to support untranslated transactions are shown in [Table A14.2](#). Each signal is described in following sections, including the property values which determine whether they are present.

**Table A14.2: Signals for Untranslated Transactions**

Name	Width	Default	Description
AWMMUSECSID, ARMMUSECSID	SECSID_WIDTH	0b00 (Non-secure)	Secure Stream Identifier for untranslated transactions.
AWMMUSID, ARMMUSID	SID_WIDTH	All zeros	Stream Identifier for untranslated transactions.
AWMMUSSIDV, ARMMUSSIDV	1	0b0	Asserted HIGH to indicate that a transaction has a valid substream identifier.
AWMMUSSID, ARMMUSSID	SSID_WIDTH	All zeros	Substream identifier for untranslated transactions.
AWMMUATST, ARMMUATST	1	0b0	Indicates that the transaction has already undergone PCIe ATS translation.
AWMMUFLOW, ARMMUFLOW	2	0b00 (Stall)	Indicates the SMMU flow for managing translation faults for this transaction.
AWMMUVALID, ARMMUVALID	1	0b0	MMU qualifier signal. When deasserted, the transaction address is a physical address and does not require translation.

When Untranslated\_Transactions is v2 or v3, **RRESP** and **BRESP** are extended to 3-bits to accommodate the signaling of the TRANSFAULT response. See [A4.3 Transaction response](#) for encodings.

In [Table A14.3](#) there is a summary of which MMU signals are present for which version of untranslated transactions.

- ‘Y’ indicates that the signal is mandatory.
- ‘C’ indicates that the presence is configurable.
- ‘-’ indicates that the signal must not be present.

**Table A14.3: Signals in each version of untranslated transactions**

Signals	Version 1	Version 2	Version 3
AxMMUSECSID	Y	Y	Y
AxMMUSID	C	C	C
AxMMUSSIDV	C	C	C
AxMMUSSID	C	C	C
AxMMUATST	C	-	-
AxMMUFLOW	-	C	C
AxMMUVALID	-	-	Y

## A14.4 Translation identifiers

Requests using virtual addressing can have up to three identifiers that are used during address translation:

- Secure Stream Identifier [A14.4.1 Secure Stream Identifier \(SECSID\)](#)
- Stream Identifier [A14.4.2 StreamID \(SID\)](#)
- Substream Identifier [A14.4.3 SubstreamID \(SSID\)](#)

During the building of a system, it is possible that the stream identifiers for a given component have some ID bits provided by the component and some ID bits that are tied off for that component. This fixes the range of values in the stream identifier name space that can be used by that component. Typically, the low-order bits are provided by the component and the high-order bits are tied off.

Any additional identifier field bits for **AxMMUSID** or **AxMMUSSID**, that are not supplied by the component or hard-coded by the interconnect, must be tied LOW.

### A14.4.1 Secure Stream Identifier (SECSID)

The Secure Stream Identifier is used to indicate the virtual address space of the request. It is transported using the **AxMMUSECSID** signal, [Table A14.4](#) shows the encodings.

**Table A14.4: AxMMUSECSID encodings**

<b>AxMMUSECSID</b>	<b>Label</b>	<b>Meaning</b>
0b00	Non-secure	Non-secure address space
0b01	Secure	Secure address space
0b10	Realm	Realm address space
0b11	RESERVED	-

The width of **AxMMUSECSID** is determined by the property **SECSID\_WIDTH**.

**Table A14.5: SECSID\_WIDTH property**

<b>Name</b>	<b>Values</b>	<b>Default</b>	<b>Description</b>
<b>SECSID_WIDTH</b>	0, 1, 2	0	Width of <b>AxMMUSECSID</b> and <b>ARMMUSECSID</b> in bits.

The following rules apply:

- **SECSID\_WIDTH** must be 0 when **Untranslated\_Transactions** is False. **AxMMUSECSID** signals are not present.
- **SECSID\_WIDTH** must be 1 when **Untranslated\_Transactions** is not False and **RME\_Support** is False. Only Non-secure and Secure address spaces can be used.
- **SECSID\_WIDTH** must be 2 when **Untranslated\_Transactions** is not False and **RME\_Support** is True.
- When **AxMMUSECSID** is Non-secure, **AxNSE/AxPROT** must indicate Non-secure.
- When **AxMMUSECSID** is Secure, **AxNSE/AxPROT** must indicate Non-secure or Secure.
- When **AxMMUSECSID** is Realm, **AxNSE/AxPROT** must indicate Non-secure or Realm.

### A14.4.2 StreamID (SID)

The StreamID can be used to map a request to a translation context in the MMU. Each address space uses a different name-space, so they can have the same Stream Identifier values.

The width of **AxMMUSID** is determined by the property **SID\_WIDTH**.

**Table A14.6: SID\_WIDTH property**

Name	Values	Default	Description
SID_WIDTH	0..32	0	StreamID width in bits, applies to AWMMUSID and ARMMUSID.

If **SID\_WIDTH** is 0, **AxMMUSID** signals are not present and the default value is used.

### A14.4.3 SubstreamID (SSID)

The SubstreamID can be used with requests that have the same StreamID to associate different application address translations to different logical blocks.

There is a separate enable signal **AxMMUSSIDV** for the SubstreamID, so a Manager can issue requests with or without a SubstreamID.

- When **AxMMUSSIDV** is deasserted, **AxMMUSSID** must be 0.

Note that a stream with a SubstreamID of 0 is different from a stream with no valid substream (**AxMMUSSIDV** is deasserted).

The width of **AxMMUSSID** is determined by the property **SSID\_WIDTH**.

**Table A14.7: SSID\_WIDTH property**

Name	Values	Default	Description
SSID_WIDTH	0..20	0	SubstreamID width in bits, applies to AWMMUSSID and ARMMUSSID.

When **SSID\_WIDTH** is 0, **AxMMUSSID** and **AxMMUSSIDV** are not present on the interface and there are no valid SubstreamIDs.

### A14.4.4 PCIe considerations

When the Untranslated\_Transactions signaling is used for interfacing to PCIe Root Complex, the following considerations apply:

- **AxMMUSECSID** must be Non-secure or Realm.
- **AxMMUSID** corresponds to the PCIe Requester ID.
- **AxMMUSSID** corresponds to the PCIe PASID.
- **AxMMUSSIDV** is asserted if the transaction had a PASID prefix, otherwise it is deasserted.

## A14.5 Translation fault flows

An untranslated transaction can indicate which flow can be used when an SMMU encounters a translation fault.

If no flow is indicated, a *Stall* flow is assumed. The property `MMUFLOW_Present` is used to indicate whether other SMMU flows are supported.

**Table A14.8: MMUFLOW\_Present property**

MMUFLOW_Present	Default	Description
True		AxMMUFLOW or AxMMUATST are present.
False	Y	AxMMUFLOW and AxMMUATST are not present.

`MMUFLOW_Present` must be False if `Untranslated_Transactions` is False.

If `MMUFLOW_Present` is True, then:

- If `Untranslated_Transactions` is True or v1, **ARMMUATST** and **AWMMUATST** are present on the interface.
- If `Untranslated_Transactions` is v2 or v3, **ARMMUFLOW** and **AWMMUFLOW** are present on the interface.

Version 1 of the specification for untranslated transactions supports the Stall and ATST flows, using the **AxMMUATST** signals.

- When **AxMMUATST** is deasserted LOW, the Stall flow is used.
- When **AxMMUATST** is asserted HIGH, the ATST flow is used.

For version 2 and above, the **AxMMUFLOW** signals are used to indicate which flow can be used.

**Table A14.9: AxMMUFLOW encodings**

AxMMUFLOW	Flow type	Meaning
0b00	Stall	The SMMU Stall flow can be used.
0b01	ATST	The SMMU ATST flow must be used.
0b10	NoStall	The SMMU NoStall flow must be used.
0b11	PRI	The SMMU PRI flow can be used.

The following sections describe each flow in turn.



### A14.5.1 Stall flow

When the Stall flow is used, software can configure the SMMU to take one of the following actions when a translation fault occurs:

- Terminate the transaction with an SLVERR response.
- Terminate the transaction with an OKAY response, data is RAZ/WI.
- Stall the translation and inform software that the translation is stalled. Software can then instruct the SMMU to terminate the transaction or update the translation tables and retry the translation. The Manager is not aware of the stall.

This flow enables software to manage translation faults and demand paging without the Manager being aware. However, it has some limitations:

- The Manager can see very long transaction latency, potentially triggering timeouts.
- Due to the dependence of software activity, the Stall flow can cause deadlocks in some systems.

For example, it is not recommended for use with PCIe because of dependencies between outgoing transactions to PCIe from a CPU, and incoming transactions from PCIe through the SMMU.

Enabling the Stall flow does not necessarily cause a stall when a translation fault occurs. Stalls only occur when enabled by software. Software does not normally enable stalling for PCIe endpoints.

### A14.5.2 ATST flow

The Address Translation Service Translated (ATST) flow indicates that the transaction has already been translated by ATS. It is only used by PCIe Root Ports.

When the flow is ATST, the transaction might still undergo some translation, depending on the configuration of the SMMU. For more information, see *Arm® System Memory Management Unit Architecture Specification* [7].

If a translation fault occurs, the transaction must be terminated with an SLVERR response.

When the flow is ATST, the following constraints apply:

- **AxMMUSECSID** must be Non-secure or Realm.
- If `Untranslated_Transactions` is True, v1 or v2 then **AxMMUSSIDV** must be LOW.

When `Untranslated_Transactions` is v3, it is permitted to assert **AxMMUSSIDV** when **AxMMUFLOW** indicates ATST. This is to enable the transport of PASID and other attributes from a PCIe transaction using the **AxMMUSSID** signal.

### A14.5.3 NoStall flow

The NoStall flow is used by a Manager that is not able to be stalled.

If a translation fault occurs when using this flow, the Subordinate must terminate the transaction with an SLVERR or OKAY response, even if software has configured the device to be stalled when a translation fault occurs.

This flow is recommended for Managers such as PCIe Root Ports which might deadlock if stalling is enabled by software.

#### A14.5.4 PRI flow

The PRI flow is designed for use with a PCIe integrated endpoint. The Manager uses the PRI flow to enable software to respond to translation faults without risking deadlock.

When the flow is PRI and a translation fault occurs, the transaction is terminated with a TRANSFAULT response. The Manager can then use a separate mechanism to request that the page is made available, before retrying the transaction. This mechanism is normally PCIe PRI.

When this flow is used, software enables ATS but no ATS features are required in hardware.

A transaction that uses this flow might still be terminated by the SMMU with an SLVERR, if the translation failed for a reason which cannot be resolved by a PRI request, for example because the SMMU is incorrectly configured.

The following rules apply to a TRANSFAULT response:

- TRANSFAULT is indicated by setting **RRESP** or **BRESP** to 0b101. See [A4.3 Transaction response](#) for all encodings.
- A TRANSFAULT response is only permitted for requests using the PRI flow.
- If TRANSFAULT is used for one response transfer, it must be used for all response transfers of a transaction.
- If **RRESP** is TRANSFAULT, the read data in that transfer is not valid.

## A14.6 Untranslated transaction qualifier

When the `Untranslated_Transactions` property is v3, a qualifier signal **AxMMUVALID** is added to the read and write request channels.

When **AxMMUVALID** is deasserted, the transaction address is a physical address and does not require translation. This enables a Manager to issue a mixture of translated and untranslated transactions.

The rules for using these signals are:

- When **AxMMUVALID** is asserted, the following signals are constrained:
  - **AxTAGOP** must be 0b00 (Invalid)
- When **AxMMUVALID** is deasserted, the following signals are not applicable and can take any value:
  - **AxMMUSECSID**
  - **AxMMUSID**
  - **AxMMUSSIDV**
  - **AxMMUSSID**
  - **AxMMUFLOW**

## A14.7 StashTranslation Opcode

The StashTranslation Opcode is a hint that an MMU should cache the table entry required to process the given address, to reduce the latency for any future transactions using that table entry.

The requirements on the MMU depend on whether the address is virtual or physical, and if the Realm Management Extension is being used:

- If **AWMMUVALID** is asserted, the StashTranslation request has a virtual address and the MMU should cache the relevant page table entry.
- If **AWMMUVALID** is deasserted, the StashTranslation request has a physical address and the MMU should cache the relevant Granule Protection Table entry.

If **RME\_Support** is False, **AWMMUVALID** must be asserted for a StashTranslation request.

The StashTranslation Opcode can be used by a Manager and supported by a Subordinate if the following property conditions apply:

- **Untranslated\_Transactions** is v1, v2, or v3.
- **Untranslated\_Transactions** is True and **Cache\_Stash\_Transactions** is True.

The rules for a StashTranslation operation are:

- The StashTranslation transaction consists of a request on the AW channel and a single response transfer on the B channel. There are no write data transfers.
- **AWSNOOP** is 0b01110 to indicate StashTranslation, **AWSNOOP\_WIDTH** can be 4 or 5.
- No stash target is supported. If present, **AWSTASHNID**, **AWSTASHNIDEN**, **AWSTASHLPID**, and **AWSTASHLPIDEN** must be LOW.
- Any legal combination of **AWCACHE** and **AWDOMAIN** values is permitted. See [Table A9.7](#).
- **AWATOP** is 0b000000 (Non-atomic transaction).
- **AWTAGOP** is 0b00 (Invalid).
- StashTranslation requests must not use the same AXI ID values that are used by non-StashTranslation transactions that are outstanding at the same time. This rule ensures that there are no ordering constraints between StashTranslation transactions and other transactions, so a Subordinate that does not stash translations can respond immediately.
- An OKAY response indicates that the StashTranslation request has been accepted, not that the translation is stashed. The request is a hint and is not guaranteed to be acted upon by a Completer.

## A14.8 UnstashTranslation Opcode

The UnstashTranslation Opcode is a hint that the page table or granule table entry that corresponds to the given transaction address and StreamID is not likely to be used again.

The requirements on the MMU depend on whether the address is virtual or physical, and if the Realm Management Extension is being used:

- If **AWMMUVALID** is asserted, the UnstashTranslation request has a virtual address and the MMU should deallocate the relevant page table entry.
- If **AWMMUVALID** is deasserted, the StashTranslation request has a physical address and the MMU should deallocate the relevant Granule Protection Table entry.

If **RME\_Support** is False, **AWMMUVALID** must be asserted for an UnstashTranslation request.

The **UnstashTranslation\_Transaction** property is used to indicate whether an interface supports the UnstashTranslation Opcode.

<b>UnstashTranslation_Transaction</b>	<b>Default</b>	<b>Description</b>
True		UnstashTranslation is supported.
False	Y	UnstashTranslation is not supported.

The following table shows compatibility between Manager and Subordinate interfaces, according to the values of the **UnstashTranslation\_Transaction** property.

<b>UnstashTranslation_Transaction</b>	<b>Subordinate: False</b>	<b>Subordinate: True</b>
<b>Manager: False</b>	Compatible.	Compatible.
<b>Manager: True</b>	Not compatible.	Compatible.

The rules for an UnstashTranslation operation are:

- The UnstashTranslation transaction consists of a request on the AW channel and a single response transfer on the B channel. There are no write data transfers.
- **AWSNOOP** is 0b10001 to indicate UnstashTranslation, **AWSNOOP\_WIDTH** must be 5.
- No stash target is supported. If present, **AWSTASHNID**, **AWSTASHNIDEN**, **AWSTASHLPID**, and **AWSTASHLPIDEN** must be LOW.
- Any legal combination of **AWCACHE** and **AWDOMAIN** values is permitted. See [Table A9.7](#).
- **AWATOP** is 0b000000 (Non-atomic transaction).
- **AWTAGOP** is 0b00 (Invalid).
- **AWID** is unique-in-flight, which means:
  - An UnstashTranslation request can only be issued if there are no outstanding transactions on the write channels using the same ID value.
  - A Manager must not issue a request on the write channels with the same ID as an outstanding UnstashTranslation transaction.
  - If present, **AWIDUNQ** must be asserted for an UnstashTranslation request.
- An OKAY response indicates that the UnstashTranslation request has been accepted, not that the translation is deallocated. The request is a hint and is not guaranteed to be acted upon by a Completer.

## Chapter A15

# Distributed Virtual Memory messages

This chapter describes how AXI supports distributed system MMUs using Distributed Virtual Memory (DVM) messages to maintain all MMUs in a virtual memory system.

It contains the following sections:

- [A15.1 Introduction to DVM transactions](#)
- [A15.2 Support for DVM messages](#)
- [A15.3 DVM messages](#)
- [A15.4 Transporting DVM messages](#)
- [A15.5 DVM Sync and Complete](#)
- [A15.6 Coherency Connection signaling](#)

## A15.1 Introduction to DVM transactions

DVM transactions are an optional feature used to pass messages that support the maintenance of a virtual memory system. There are two types of DVM transactions: DVM message and DVM Complete.

A DVM message supports the following operations:

- TLB Invalidate
- Branch Predictor Invalidate
- Physical Instruction Cache Invalidate
- Virtual Instruction Cache Invalidate
- Synchronization
- Hint

DVM message requests are sent from a Subordinate interface, usually on an interconnect, to a Manager interface using the snoop request (AC) channel.

DVM message responses are sent from a Manager to Subordinate interface using the snoop response (CR) channel.

A DVM Complete transaction is issued on the read request channel (AR) in response to a DVM Synchronization (Sync) message, to indicate that all required operations and any associated transactions have completed.

## A15.2 Support for DVM messages

The DVM\_Message\_Support property is used to indicate if an interface supports DVM messages.

**Table A15.1: DVM\_Message\_Support property**

DVM_Message_Support	Default	Description
Receiver		DVM message and Synchronization transactions are supported from Subordinate to Manager interfaces on the AC/CR channels. DVM Complete transactions are supported from Manager to Subordinate interfaces on the AR/R channels.
False	Y	DVM message transactions are not supported.

Note that the Bidirectional option for DVM\_Message\_Support in previous issues of this specification is deprecated in this specification.

DVM Complete messages require that **ARDOMAIN** is set to Shareable. Therefore, when DVM\_Message\_Support is Receiver the Shareable\_Transactions property must be True.

DVM messages were introduced in the Armv7 architecture and were extended in Armv8, Armv8.1, Armv8.4, and Armv9.2 architectures. It is essential that interfaces initiating and receiving DVM messages support the same architecture versions.

The following properties define the version that is supported by an interface:

- DVM\_v8
- DVM\_v8.1
- DVM\_v8.4
- DVM\_v9.2

Each property can take the values: True or False. If a property is not declared, then it is considered False.

In [Table A15.2](#) there is an indication of which message versions are supported, depending on the property values. A component that supports DVM messages from a specific version must also support earlier architecture versions.

**Table A15.2: DVM message versions**

DVM property				Architecture support				
DVM_v9.2	DVM_v8.4	DVM_v8.1	DVM_v8	Armv9.2	Armv8.4	Armv8.1	Armv8	Armv7
True	True or False	True or False	True or False	Y	Y	Y	Y	Y
False	True	True or False	True or False	-	Y	Y	Y	Y
False	False	True	True or False	-	-	Y	Y	Y
False	False	False	True	-	-	-	Y	Y
False	False	False	False	-	-	-	-	Y



## A15.3 DVM messages

The following DVM messages are supported by the protocol:

- TLB Invalidate
- Branch Predictor Invalidate
- Physical Instruction Cache Invalidate
- Virtual Instruction Cache Invalidate
- Synchronization
- Hint

DVM transactions only operate on read-only structures, such as Instruction cache, Branch Predictor, and TLB, and therefore only invalidation operations are required. The concept of cleaning does not apply to a read-only structure. This means that it is functionally correct to invalidate more entries than the DVM message requires, although the extra invalidations can affect performance.

### A15.3.1 DVM message fields

The fields in DVM messages are shown in [Table A15.3](#).

**Table A15.3: DVM message fields**

Name	Width	Description
VA	32-57	Virtual Address
PA	32-52	Physical Address
ASID	8 or 16	Address Space ID
ASIDV	1	Asserted HIGH to indicate that the ASID field is valid. When deasserted, ASID must be zero.
VMID	8 or 16	Virtual Machine ID
VMIDV	1	Asserted HIGH to indicate that the VMID field is valid. When deasserted, VMID must be zero.
DVMType	3	DVM message type: <ul style="list-style-type: none"> <li>0b000 TLB Invalidate (TLBI)</li> <li>0b001 Branch Predictor Invalidate (BPI)</li> <li>0b010 Physical Instruction Cache Invalidate (PICl)</li> <li>0b011 Virtual Instruction Cache Invalidate (VICl)</li> <li>0b100 Synchronization (Sync)</li> <li>0b101 Reserved</li> <li>0b110 Hint</li> <li>0b111 Reserved</li> </ul>

*Continued on next page*

Table A15.3 – Continued from previous page

Name	Width	Description
Exception	2	Indicates the exception level that the transaction applies to:
		0b00 Hypervisor and all Guest OS
		0b01 EL3
		0b10 Guest OS
		0b11 Hypervisor
Security	2	Indicates which Security state the invalidation applies to. See <a href="#">Table A15.6</a> for encodings.
Leaf	1	Indicates whether only leaf entries are invalidated:
		0b0 Invalidate all associated translations.
		0b1 Invalidate Leaf Entry only.
Stage	2	Indicates which stages are invalidated:
		0b00 Armv7: Stage of invalidation varies with invalidation type. Armv8 and later: Stage 1 and Stage 2 invalidation.
		0b01 Stage 1 only invalidation.
		0b10 Stage 2 only invalidation.
		0b11 GPT
Num	5	Used as a constant multiplication factor in the range calculation. All binary values are valid.
Scale	2	Used as a constant in address range exponent calculation. All binary values are valid.
TTL	2	Hint of Translation Table Level (TTL) which includes the addresses to be invalidated. See <a href="#">Table A15.4</a> and <a href="#">Table A15.5</a> for details.
TG	2	Translation Granule (TG).
		For TLB Invalidations by range, TG indicates the granule size:
		0b00 Reserved.
		0b01 4K
		0b10 16K
0b11 64K		
For non-range TLB Invalidations, TG and TTL indicate the table level hint, see <a href="#">Table A15.5</a> .		
VI	16	Virtual Index, used for PICI messages.
VIV	2	Virtual Index Valid:
		0b00 Virtual Index not valid
		0b01 Reserved
		0b10 Reserved
		0b11 Virtual Index valid

Continued on next page

Table A15.3 – Continued from previous page

<b>Name</b>	<b>Width</b>	<b>Description</b>
IS	4	Invalidation Size encoding for GPT TLBI by PA operations:
		0b0000    4KB
		0b0001    16KB
		0b0010    64KB
		0b0011    2MB
		0b0100    32MB
		0b0101    512MB
		0b0110    1GB
		0b0111    16GB
		0b1000    64GB
		0b1001    512GB
		0b1010– 0b1111    Reserved
Addr	1	Indicates if the message includes an address.
		0b0        No address information.
		0b1        Address included, this is a two-part message.
Range	1	Asserted HIGH to indicate that the 2nd part indicates an address range.
Completion	1	Asserted HIGH to indicate that a Completion message is required.

**TLB Invalidate level hint**

For TLB Invalidation by address range, the TTL field indicates which level of translation table walk holds the leaf entry for the address being invalidated. The encodings are shown in [Table A15.4](#).

**Table A15.4: Leaf entry hint for range-based TLB Invalidations**

TTL	Meaning
0b00	No level hint information.
0b01	The leaf entry is on level 1 of the translation table walk.
0b10	The leaf entry is on level 2 of the translation table walk.
0b11	The leaf entry is on level 3 of the translation table walk.

For TLB Invalidation by non-range address, the TTL and TG fields indicate which level of translation table walk holds the leaf entry for the address being invalidated. The encodings are shown in [Table A15.5](#).

**Table A15.5: Leaf entry hint for non-range TLB Invalidations**

TG	TTL	Meaning
0b00	0b00	No level hint
	0b01	Reserved
	0b10	Reserved
	0b11	Reserved
0b01	0b00	No level hint
	0b01	The leaf entry is on level 1 of the translation table walk.
	0b10	The leaf entry is on level 2 of the translation table walk.
	0b11	The leaf entry is on level 3 of the translation table walk.
0b10	0b00	No level hint
	0b01	No level hint
	0b10	The leaf entry is on level 2 of the translation table walk.
	0b11	The leaf entry is on level 3 of the translation table walk.
0b11	0b00	No level hint
	0b01	The leaf entry is on level 1 of the translation table walk.
	0b10	The leaf entry is on level 2 of the translation table walk.
	0b11	The leaf entry is on level 3 of the translation table walk.

**Security field**

The Security field has different meanings depending on the DVM Type, as shown in [Table A15.6](#).

**Table A15.6: Security field encodings per DVM Type**

Security	TLBI	BPI	PICI All	PICI by PA	VICI
0b00	Realm	Secure and Non-secure	Root, Realm, Secure, and Non-secure	Root	Secure and Non-secure
0b01	Non-secure address from a Secure context	Reserved	Realm and Non-secure	Realm	Reserved
0b10	Secure	Reserved	Secure and Non-secure	Secure	Secure
0b11	Non-secure	Reserved	Non-secure	Non-secure	Non-secure

### ASID field

The ASID field contains an 8-bit or 16-bit Address Space ID.

- Armv7 supports only an 8-bit ASID.
- Armv8 and above support both 8-bit and 16-bit ASID.

It cannot be determined from a DVM message whether the message uses an 8-bit or 16-bit ASID. All 8-bit ASID messages are required to set the ASID[15:8] bits to zero.

It is expected that most systems will use a single ASID size across the entire system, either 8-bit ASID or 16-bit ASID.

In a system that contains a mix of 8-bit ASID and 16-bit ASID components, it is expected that all maintenance is done by an agent that uses 16-bit ASID. This ensures that the agent can perform maintenance on both the 8-bit ASID and 16-bit ASID components.

The interoperability requirements are:

- For an 8-bit ASID agent sending a message to a 16-bit ASID agent, a message appears as a 16-bit ASID with the upper 8 bits set to zero.
- For a 16-bit ASID agent sending a message to an 8-bit VMID agent:
  - If the upper 8 bits are zero, the message was received correctly.
  - If the upper 8 bits are non-zero, then over-invalidation will occur, since the 8-bit ASID agent ignores the upper 8 bits.

### VMID field

The VMID field contains an 8-bit or 16-bit Virtual Machine ID.

- Armv7 and Armv8 support only 8-bit VMIDs.
- Armv8.1 and above support both 8-bit and 16-bit VMIDs.

It cannot be determined from a DVM message whether the message uses an 8-bit or 16-bit VMID. All 8-bit VMID messages are required to set the VMID[15:8] field to zero.

It is expected that most systems use a single VMID size across the entire system, either 8-bit VMID or 16-bit VMID.

In a system that contains a mix of 8-bit VMID and 16-bit VMID components, it is expected that all maintenance is done by an agent that uses 16-bit VMID. This ensures that the agent can perform maintenance on both the 8-bit VMID and 16-bit VMID components.

The interoperability requirements are:

- For an 8-bit VMID agent sending a message to a 16-bit VMID agent, a message appears as a 16-bit VMID with the upper 8 bits set to zero.
- For a 16-bit VMID agent sending a message to an 8-bit VMID agent:
  - If the upper 8 bits are zero, the message was received correctly.
  - If the upper 8 bits are nonzero, then over-invalidation will occur, since the 8-bit VMID agent ignores the upper 8 bits.

When Armv8.1 and above is supported, **ACVMIDEXT** is included on the AC channel to transport the upper byte of 16-bit VMIDs. See [A15.4 Transporting DVM messages](#) for more details.

### A15.3.2 TLB Invalidate messages

This section details the TLB Invalidate (TLBI) message.

For a TLBI message some fields have a fixed value, as shown in [Table A15.7](#).

**Table A15.7: Fixed field values for a TLBI message**

Name	Value	Meaning
DVMType	0b000	TLB Invalidate opcode.
Completion	0b0	Completion not required.

The entries on which the TLBI must operate depends on the fields in the message. All supported TLBI operations are shown in [Table A15.8](#).

The Arm column indicates the minimum Arm architecture version required to support the message.

The field to signal mappings for TLBI messages are detailed in [Table A15.20](#).

**Table A15.8: TLBI messages**

Operation	Arm	Exception	Security	VMIDV	ASIDV	Leaf	Stage	Addr
EL3 TLBI all	v8	0b01	0b10	0b0	0b0	0b0	0b00	0b0
EL3 TLBI by VA	v8	0b01	0b10	0b0	0b0	0b0	0b00	0b1
EL3 TLBI by VA, Leaf only	v8	0b01	0b10	0b0	0b0	0b1	0b00	0b1
Secure Guest OS TLBI by Non-secure IPA	v8.4	0b10	0b01	0b1	0b0	0b0	0b10	0b1
Secure Guest OS TLBI by Non-secure IPA, Leaf only	v8.4	0b10	0b01	0b1	0b0	0b1	0b10	0b1
Secure TLBI all	v7	0b10	0b10	0b0	0b0	0b0	0b00	0b0
Secure TLBI by VA	v7	0b10	0b10	0b0	0b0	0b0	0b00	0b1
Secure TLBI by VA, Leaf only	v8	0b10	0b10	0b0	0b0	0b1	0b00	0b1
Secure TLBI by ASID	v7	0b10	0b10	0b0	0b1	0b0	0b00	0b0
Secure TLBI by ASID and VA	v7	0b10	0b10	0b0	0b1	0b0	0b00	0b1

*Continued on next page*

Table A15.8 – Continued from previous page

Operation	Arm	Exception	Security	VMIDV	ASIDV	Leaf	Stage	Addr
Secure TLBI by ASID and VA, Leaf only	v8	0b10	0b10	0b0	0b1	0b1	0b00	0b1
Secure Guest OS TLBI all	v8.4	0b10	0b10	0b1	0b0	0b0	0b00	0b0
Secure Guest OS TLBI by VA	v8.4	0b10	0b10	0b1	0b0	0b0	0b00	0b1
Secure Guest OS TLBI all, Stage 1 only	v8.4	0b10	0b10	0b1	0b0	0b0	0b01	0b0
Secure Guest OS TLBI by Secure IPA	v8.4	0b10	0b10	0b1	0b0	0b0	0b10	0b1
Secure Guest OS TLBI by VA, Leaf only	v8.4	0b10	0b10	0b1	0b0	0b1	0b00	0b1
Secure Guest OS TLBI by Secure IPA, Leaf only	v8.4	0b10	0b10	0b1	0b0	0b1	0b10	0b1
Secure Guest OS TLBI by ASID	v8.4	0b10	0b10	0b1	0b1	0b0	0b00	0b0
Secure Guest OS TLBI by ASID and VA	v8.4	0b10	0b10	0b1	0b1	0b0	0b00	0b1
Secure Guest OS TLBI by ASID and VA, Leaf only	v8.4	0b10	0b10	0b1	0b1	0b1	0b00	0b1
All OS TLBI all	v7	0b10	0b11	0b0	0b0	0b0	0b00	0b0
Guest OS TLBI all, Stage 1 and 2	v7	0b10	0b11	0b1	0b0	0b0	0b00	0b0
Guest OS TLBI by VA	v7	0b10	0b11	0b1	0b0	0b0	0b00	0b1
Guest OS TLBI all, Stage 1 only	v8	0b10	0b11	0b1	0b0	0b0	0b01	0b0
Guest OS TLBI by IPA	v8	0b10	0b11	0b1	0b0	0b0	0b10	0b1
Guest OS TLBI by VA, Leaf only	v8	0b10	0b11	0b1	0b0	0b1	0b00	0b1
Guest OS TLBI by IPA, Leaf only	v8	0b10	0b11	0b1	0b0	0b1	0b10	0b1
Guest OS TLBI by ASID	v7	0b10	0b11	0b1	0b1	0b0	0b00	0b0
Guest OS TLBI by ASID and VA	v7	0b10	0b11	0b1	0b1	0b0	0b00	0b1
Guest OS TLBI by ASID and VA, Leaf only	v8	0b10	0b11	0b1	0b1	0b1	0b00	0b1
Secure Hypervisor TLBI all	v8.4	0b11	0b10	0b0	0b0	0b0	0b00	0b0
Secure Hypervisor TLBI by VA	v8.4	0b11	0b10	0b0	0b0	0b0	0b00	0b1
Secure Hypervisor TLBI by VA, Leaf only	v8.4	0b11	0b10	0b0	0b0	0b1	0b00	0b1
Secure Hypervisor TLBI by ASID	v8.4	0b11	0b10	0b0	0b1	0b0	0b00	0b0
Secure Hypervisor TLBI by ASID and VA	v8.4	0b11	0b10	0b0	0b1	0b0	0b00	0b1
Secure Hypervisor TLBI by ASID and VA, Leaf only	v8.4	0b11	0b10	0b0	0b1	0b1	0b00	0b1
Hypervisor TLBI all	v7	0b11	0b11	0b0	0b0	0b0	0b00	0b0
Hypervisor TLBI by VA	v7	0b11	0b11	0b0	0b0	0b0	0b00	0b1
Hypervisor TLBI by VA, Leaf only	v8	0b11	0b11	0b0	0b0	0b1	0b00	0b1
Hypervisor TLBI by ASID	v8.1	0b11	0b11	0b0	0b1	0b0	0b00	0b0

Continued on next page

Table A15.8 – Continued from previous page

Operation	Arm	Exception	Security	VMIDV	ASIDV	Leaf	Stage	Addr
Hypervisor TLBI by ASID and VA	v8.1	0b11	0b11	0b0	0b1	0b0	0b00	0b1
Hypervisor TLBI by ASID and VA, Leaf only	v8.1	0b11	0b11	0b0	0b1	0b1	0b00	0b1
Realm TLBI all	v9.2	0b10	0b00	0b0	0b0	0b0	0b00	0b0
Realm Guest OS TLBI all, Stage 1 only	v9.2	0b10	0b00	0b1	0b0	0b0	0b01	0b0
Realm Guest OS TLBI all, Stage 1 and 2	v9.2	0b10	0b00	0b1	0b0	0b0	0b00	0b0
Realm Guest OS TLBI by VA	v9.2	0b10	0b00	0b1	0b0	0b0	0b00	0b1
Realm Guest OS TLBI by VA, Leaf only	v9.2	0b10	0b00	0b1	0b0	0b1	0b00	0b1
Realm Guest OS TLBI by ASID	v9.2	0b10	0b00	0b1	0b1	0b0	0b00	0b0
Realm Guest OS TLBI by ASID and VA	v9.2	0b10	0b00	0b1	0b1	0b0	0b00	0b1
Realm Guest OS TLBI by ASID and VA, Leaf only	v9.2	0b10	0b00	0b1	0b1	0b1	0b00	0b1
Realm Guest OS TLBI by IPA	v9.2	0b10	0b00	0b1	0b0	0b0	0b10	0b1
Realm Guest OS TLBI by IPA, Leaf only	v9.2	0b10	0b00	0b1	0b0	0b1	0b10	0b1
Realm Hypervisor TLBI all	v9.2	0b11	0b00	0b0	0b0	0b0	0b00	0b0
Realm Hypervisor TLBI by VA	v9.2	0b11	0b00	0b0	0b0	0b0	0b00	0b1
Realm Hypervisor TLBI by VA, Leaf only	v9.2	0b11	0b00	0b0	0b0	0b1	0b00	0b1
Realm Hypervisor TLBI by ASID	v9.2	0b11	0b00	0b0	0b1	0b0	0b00	0b0
Realm Hypervisor TLBI by ASID and VA	v9.2	0b11	0b00	0b0	0b1	0b0	0b00	0b1
Realm Hypervisor TLBI by ASID and VA, Leaf only	v9.2	0b11	0b00	0b0	0b1	0b1	0b00	0b1
GPT TLBI by PA	v9.2	0b01	0b10	0b0	0b0	0b0	0b11	0b1
GPT TLBI by PA, Leaf only	v9.2	0b01	0b10	0b0	0b0	0b1	0b11	0b1
GPT TLBI all	v9.2	0b01	0b10	0b0	0b0	0b0	0b11	0b0



### **TLB Invalidate by Range**

When Armv8.4 or later is supported, TLBI operations by IPA or VA have the option to operate on an address range if the Range field is 0b1.

The Range field must be 0b0 if either:

- Armv8.4 is not supported.
- The message type is not TLB Invalidate by IPA or VA.

When the Range field is 0b1, the address range to invalidate is calculated using the following formula:

$$BaseAddr \leq AddressRange < BaseAddr + \left( (Num + 1) \times 2^{(5 \times Scale + 1)} \times TG \right)$$

Where:

- *TG* is the Transaction Granule, provided in the message. See [Table A15.3](#) for encodings.
- *Scale* is provided in the message, it can take any value from 0-3.
- *Num* is provided in the message, it can take any value from 0-31.
- *BaseAddr* is the base address of the range, based on TG:
  - 4K: BaseAddr is VA[MaxVA:12].
  - 16K: BaseAddr is VA[MaxVA:14], VA[13:12] must be zero.
  - 64K: BaseAddr is VA[MaxVA:16], VA[15:12] must be zero.

A TLBI by Range is a 2-part message with field mappings described in [Table A15.20](#).

### **GPT TLB Invalidate**

Granule Protection Table (GPT) TLBI by PA operations perform range-based invalidation and invalidate TLB entries starting from the PA, within the range as specified in the *Invalidation Size* (IS) field. See [Table A15.3](#) for encodings.

If the PA is not aligned to the IS value, no TLB entries are required to be invalidated.

The IS field is applicable only in GPT TLBI by PA operations.

- A *GPT TLBI all* message is signaled using a 1-part message with the Range field set to 0b0.
- A *GPT TLBI by PA* message is signaled using a 2-part message with the Range field set to 0b1.

The field to signal mappings for GPT TLBI messages are shown in [Table A15.20](#).

### A15.3.3 Branch Predictor Invalidate messages

The *Branch Predictor Invalidate* (BPI) message is used to invalidate virtual addresses from branch predictors. A BPI message is signaled using a 1-part or 2-part message with field to signal mappings detailed in [Table A15.21](#). The fixed field values for a BPI message are shown in [Table A15.9](#).

**Table A15.9: Fixed field values for a BPI message**

Name	Value	Meaning
DVMType	0b001	Branch Predictor Invalidate opcode
Completion	0b0	Completion not required
Range	0b0	Address is not a range
VMIDV	0b0	VMID field not valid
ASIDV	0b0	ASID field not valid
Exception	0b00	Hypervisor and all Guest OS
Security	0b00	Secure and Non-secure
Leaf	0b0	Leaf information is N/A
Stage	0b00	Stage information is N/A

All supported BPI operations are shown in [Table A15.10](#).

The Arm column indicates the minimum Arm architecture version required to support the message.

**Table A15.10: BPI messages**

Operation	Arm	Addr
Branch Predictor Invalidate all	v7	0b0
Branch Predictor Invalidate by VA	v7	0b1

### A15.3.4 Instruction cache invalidations

Instruction caches can use either a physical address or a virtual address to tag the data they contain. A system might contain a mixture of both forms of cache.

The DVM protocol includes instruction cache invalidation operations that use physical addresses and operations that use virtual addresses. A component that receives DVM messages must support both forms of message, independent of the style of instruction cache implemented. It might be necessary to over-invalidate in the case where a message is received in a format that is not native to the cache type.

#### **Physical Instruction Cache Invalidate**

This section lists the *Physical Instruction Cache Invalidate* (PICI) operations that the DVM message supports. This message type is also used for Instruction Caches which are *Virtually Indexed Physically Tagged* (VIPT).

A PICI message is signaled using a 1-part or 2-part message with field to signal mappings detailed in [Table A15.22](#). The fixed field values for a PICI message are shown in [Table A15.11](#).

**Table A15.11: Fixed field values for a PICI message**

Name	Value	Meaning
DVMType	0b010	Physical Instruction Cache Invalidate opcode
Completion	0b0	Completion not required
Range	0b0	Address is not a range
Exception	0b00	Hypervisor and all Guest OS
Leaf	0b0	Leaf information is N/A
Stage	0b00	Stage information is N/A

All supported PICI operations are shown in [Table A15.12](#).

**Table A15.12: PICI messages**

Operation	Arm	Security	VIV	Addr
PICI all Root, Realm, Secure and Non-secure	v9.2	0b00	0b00	0b0
PICI by PA without Virtual Index, Root only	v9.2	0b00	0b00	0b1
PICI by PA with Virtual Index, Root only	v9.2	0b00	0b11	0b1
PICI all Realm and Non-secure	v9.2	0b01	0b00	0b0
PICI by PA without Virtual Index, Realm only	v9.2	0b01	0b00	0b1
PICI by PA with Virtual Index, Realm only	v9.2	0b01	0b11	0b1
PICI all Secure and Non-secure	v7	0b10	0b00	0b0
PICI by PA without Virtual Index, Secure only	v7	0b10	0b00	0b1
PICI by PA with Virtual Index, Secure only	v7	0b10	0b11	0b1
PICI all, Non-secure only	v7	0b11	0b00	0b0
PICI by PA without Virtual Index, Non-secure only	v7	0b11	0b00	0b1
PICI by PA with Virtual Index, Non-secure only	v7	0b11	0b11	0b1

When the Virtual Index Valid (VIV) field is 0b11, then VI[27:12] is used as part of the Physical Address.

Note that in previous issues of this specification, a *PICI all* with Security value of 0b10 was incorrectly labeled as *Secure only* when it should have been *Secure and Non-secure*.

### Virtual Instruction Cache Invalidate

This section lists the *Virtual Instruction Cache Invalidate* (VICI) operations that the DVM message supports.

A VICI message is signaled using a 1-part or 2-part message with field to signal mappings detailed in [Table A15.22](#).

The fixed field values for a VICI message are shown in [Table A15.13](#).

**Table A15.13: Fixed field values for a VICI message**

Name	Value	Meaning
DVMType	0b011	Virtual Instruction Cache Invalidate opcode
Completion	0b0	Completion not required
Range	0b0	Address is not a range
Leaf	0b0	Leaf information is N/A
Stage	0b00	Stage information is N/A

All supported VICI operations are shown in [Table A15.14](#).

The Arm column indicates the minimum Arm architecture version required to support the message.

**Table A15.14: VICI messages**

Operation	Arm	Exception	Security	VMIDV	ASIDV	Addr
Hypervisor and all Guest OS VICI all, Secure and Non-secure	v7	0b00	0b00	0b0	0b0	0b0
Hypervisor and all Guest OS VICI all, Non-secure only	v7	0b00	0b11	0b0	0b0	0b0
All Guest OS VICI by ASID and VA, Secure only	v7	0b10	0b10	0b0	0b1	0b1
All Guest OS VICI by VMID, Secure only	v8.4	0b10	0b10	0b1	0b0	0b0
All Guest OS VICI by ASID, VA and VMID, Secure only	v8.4	0b10	0b10	0b1	0b1	0b1
All Guest OS VICI by VMID, Non-secure only	v7	0b10	0b11	0b1	0b0	0b0
All Guest OS VICI by ASID, VA and VMID, Non-secure only	v7	0b10	0b11	0b1	0b1	0b1
Hypervisor VICI by VA, Non-secure only	v7	0b11	0b11	0b0	0b0	0b1
Hypervisor VICI by ASID and VA, Non-secure only	v8.1	0b11	0b11	0b0	0b1	0b1

### A15.3.5 Synchronization message

A Synchronization (Sync) message is used when the requester needs to know when all previous invalidations are complete. For more information on how to use the Sync message, see [A15.5 DVM Sync and Complete](#).

A Sync message is signaled using a 1-part message with field to signal mappings detailed in [Table A15.21](#).

The fixed field values for a Sync message are shown in [Table A15.15](#).

**Table A15.15: Fixed field values for a Sync message**

Name	Value	Meaning
DVMType	0b100	Sync opcode
Completion	0b1	Completion required
ASIDV	0b0	No ASID information
VMIDV	0b0	No VMID information
Addr	0b0	No address information
Range	0b0	No address range
Exception	0b00	Exception information is N/A
Security	0b00	Security information is N/A
Leaf	0b0	Leaf information is N/A
Stage	0b00	Stage information is N/A

### A15.3.6 Hint message

A reserved message address space is provided for future Hint messages.

The fixed field values for a Hint message are shown in [Table A15.16](#).

**Table A15.16: Fixed field values for a Hint message**

Name	Value	Meaning
DVMType	0b110	Hint opcode
Completion	0b0	Completion not required

## A15.4 Transporting DVM messages

A DVM message transaction consists of one request transfer on the snoop request (AC) channel and one response on the snoop response (CR) channel. There can be one or two transactions per message, the *Addr* field in the first request indicates if another transaction is required.

DVM messages that do not include an address are sent using one transaction.

DVM messages that include an address are sent using two transactions.

An interconnect is usually used to replicate and distribute DVM message requests to participating Manager components. Managers can use the Coherency Connection signaling to opt into receiving messages at runtime, see [A15.6 Coherency Connection signaling](#).

Flows for one-part and two-part messages are shown in [Figure A15.1](#).

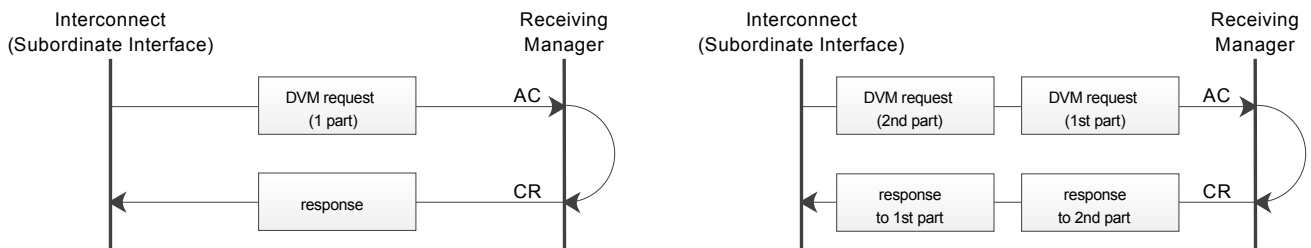

**Figure A15.1: DVM message flows**

The following rules apply to two-part DVM messages:

- The requests are always sent as successive transfers, with no other message requests between them.
- A component issuing a two-part DVM message must be able to issue the second part of the message without requiring a response to the first part of the message.

### A15.4.1 Signaling for DVM messages

A DVM request is transported on the snoop request channel from a Subordinate to a Manager interface. [Table A15.17](#) shows the signals that form the snoop request channel.

**Table A15.17: Snoop request channel**

Name	Width	Default	Description
ACVALID	1	-	Asserted high to indicate that the signals on the AC channel are valid.
ACREADY	1	-	Asserted high to indicate that a transfer on the AC channel can be accepted.
ACADDR	ADDR_WIDTH	-	Used to carry the payload for DVM message requests.
ACVMIDEXT	4	-	Extension to support 16-bit VMID in DVM messages.
ACTRACE	1	-	Trace signal associated with the snoop request channel.

The response to a DVM request is transported on the snoop response channel from a Manager to a Subordinate interface. [Table A15.18](#) shows the signals that form the snoop response channel.

**Table A15.18: Snoop response channel**

Name	Width	Default	Description
CRVALID	1	-	Asserted high to indicate that the signals on the CR channel are valid.
CRREADY	1	-	Asserted high to indicate that a transfer on the CR channel can be accepted.
CRTRACE	1	-	Trace signal associated with the snoop response channel.

A DVM response acknowledges that the request has been received but does not indicate the success or failure of a DVM message. Reordering is not supported on the AC or CR channels, so responses are returned in the same order as the AC requests were issued.

The **ACTRACE** and **CRTRACE** signals act the same as trace signals on other channels, see [A13.3 Trace signals](#) for more information.

Note that previous issues of this specification included a snoop response indicator, **CRRESP** to indicate an error response. This has not been widely used, so is deprecated as part of the specification simplification process.

#### **Rules for snoop channels**

The rules for snoop channel signals are similar to those for other channels:

- **ACVALID** must only be asserted by a Subordinate when there is valid address and control information.
- When asserted, **ACVALID** must remain asserted until the rising clock edge after the Manager asserts the **ACREADY** signal.
- **CRVALID** is asserted to indicate that the Manager has acknowledged the DVM message.
- When asserted, **CRVALID** must remain asserted until the rising clock edge after the Subordinate asserts the **CRREADY** signal.

The rules for dependencies between the snoop request and response channels are listed below and illustrated in [Figure A15.2](#).

- The Subordinate must not wait for the Manager to assert **ACREADY** before asserting **ACVALID**.
- The Manager can wait for **ACVALID** to be asserted before it asserts **ACREADY**.
- The Manager can assert **ACREADY** before **ACVALID** is asserted.
- The Manager must wait for both **ACVALID** and **ACREADY** to be asserted before it asserts **CRVALID** to indicate that a valid response is available.
- The Manager must not wait for the Subordinate to assert **CRREADY** before asserting **CRVALID**.
- The Subordinate can wait for **CRVALID** to be asserted before it asserts **CRREADY**.
- The Subordinate can assert **CRREADY** before **CRVALID** is asserted.

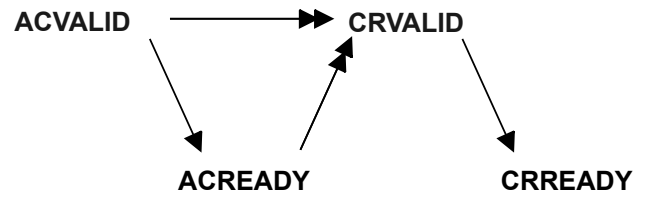

Figure A15.2: Snoop transaction handshake dependencies

### A15.4.2 Address widths in DVM messages

The property ADDR\_WIDTH is used to specify the width of ARADDR, AWADDR, and ACADDR. This sets the physical address width used by an interface.

The ACADDR signal is also used to transport the Virtual Address (VA), so the required VA width also sets a minimum constraint on ADDR\_WIDTH. Table A15.19 shows some common VA widths and the minimum ADDR\_WIDTH required.

Table A15.19: Common VA widths and minimum ADDR\_WIDTH

VA width	Minimum ADDR_WIDTH
32	32
41	40
49	44
53	48
57	48

VA widths greater than 57-bits are not supported.

If the PA width exceeds the VA width, then virtual address operations might receive additional address information in a DVM message. In this case, any additional address information must be ignored and operations performed using only the supported address bits.

If a component supports a larger VA width than its PA width, the component must take appropriate action regarding the additional physical address bits. See A4.1.5 *Transfer address* for more details on mismatched address widths.

### A15.4.3 Mapping message fields to signals

The fields in DVM messages are transported using bits of the ACADDR and ACVMIDEXT signals.

There are different mappings for each message type, shown in the tables below. The bit position allocation might appear irregular but is used to ease the translation between implementations with different address widths.

For Hint messages, the Completion (0b0) and DVMTType (0b110) fields are at ACADDR[15] and ACADDR[14:12] respectively, other mappings are IMPLEMENTATION DEFINED.

The mappings for TLB Invalidate messages are shown in Table A15.20.



**Table A15.20: Field mappings for TLB Invalidate messages**

Signal	TLBI 1-part	TLBI 1st of 2-part	TLBI 2nd part by VA	TLBI 2nd part by range	GPT TLBI 1st part	GPT TLBI 2nd part
ACADDR[51]	0b0	0b0	0b0	0b0	0b0	PA[51]
ACADDR[50]	0b0	0b0	0b0	0b0	0b0	PA[50]
ACADDR[49]	0b0	0b0	0b0	0b0	0b0	PA[49]
ACADDR[48]	0b0	0b0	0b0	0b0	0b0	PA[48]
ACADDR[47]	0b0	VA[56]	VA[52]	VA[52]	0b0	PA[47]
ACADDR[46]	0b0	VA[55]	VA[51]	VA[51]	0b0	PA[46]
ACADDR[45]	0b0	VA[54]	VA[50]	VA[50]	0b0	PA[45]
ACADDR[44]	0b0	VA[53]	VA[49]	VA[49]	0b0	PA[44]
ACADDR[43]	VMID[15]	VA[48]	VA[44]	VA[44]	0b0	PA[43]
ACADDR[42]	VMID[14]	VA[47]	VA[43]	VA[43]	0b0	PA[42]
ACADDR[41]	VMID[13]	VA[46]	VA[42]	VA[42]	0b0	PA[41]
ACADDR[40]	VMID[12]	VA[45]	VA[41]	VA[41]	0b0	PA[40]
ACADDR[39]	ASID[15]	ASID[15]	VA[39]	VA[39]	0b0	PA[39]
ACADDR[38]	ASID[14]	ASID[14]	VA[38]	VA[38]	0b0	PA[38]
ACADDR[37]	ASID[13]	ASID[13]	VA[37]	VA[37]	0b0	PA[37]
ACADDR[36]	ASID[12]	ASID[12]	VA[36]	VA[36]	0b0	PA[36]
ACADDR[35]	ASID[11]	ASID[11]	VA[35]	VA[35]	0b0	PA[35]
ACADDR[34]	ASID[10]	ASID[10]	VA[34]	VA[34]	0b0	PA[34]
ACADDR[33]	ASID[9]	ASID[9]	VA[33]	VA[33]	0b0	PA[33]
ACADDR[32]	ASID[8]	ASID[8]	VA[32]	VA[32]	0b0	PA[32]
ACADDR[31]	VMID[7]	VMID[7]	VA[31]	VA[31]	0b0	PA[31]
ACADDR[30]	VMID[6]	VMID[6]	VA[30]	VA[30]	0b0	PA[30]
ACADDR[29]	VMID[5]	VMID[5]	VA[29]	VA[29]	0b0	PA[29]
ACADDR[28]	VMID[4]	VMID[4]	VA[28]	VA[28]	0b0	PA[28]
ACADDR[27]	VMID[3]	VMID[3]	VA[27]	VA[27]	0b0	PA[27]
ACADDR[26]	VMID[2]	VMID[2]	VA[26]	VA[26]	0b0	PA[26]
ACADDR[25]	VMID[1]	VMID[1]	VA[25]	VA[25]	0b0	PA[25]
ACADDR[24]	VMID[0]	VMID[0]	VA[24]	VA[24]	0b0	PA[24]
ACADDR[23]	ASID[7]	ASID[7]	VA[23]	VA[23]	0b0	PA[23]
ACADDR[22]	ASID[6]	ASID[6]	VA[22]	VA[22]	0b0	PA[22]
ACADDR[21]	ASID[5]	ASID[5]	VA[21]	VA[21]	0b0	PA[21]

*Continued on next page*

Table A15.20 – Continued from previous page

Signal	TLBI 1-part	TLBI 1st of 2-part	TLBI 2nd part by VA	TLBI 2nd part by range	GPT TLBI 1st part	GPT TLBI 2nd part
ACADDR[20]	ASID[4]	ASID[4]	VA[20]	VA[20]	0b0	PA[20]
ACADDR[19]	ASID[3]	ASID[3]	VA[19]	VA[19]	0b0	PA[19]
ACADDR[18]	ASID[2]	ASID[2]	VA[18]	VA[18]	0b0	PA[18]
ACADDR[17]	ASID[1]	ASID[1]	VA[17]	VA[17]	0b0	PA[17]
ACADDR[16]	ASID[0]	ASID[0]	VA[16]	VA[16]	0b0	PA[16]
ACADDR[15]	0b0 (Completion)	0b0 (Completion)	VA[15]	VA[15]	0b0 (Completion)	PA[15]
ACADDR[14]	0b0 (DVMTyep[2])	0b0 (DVMTyep[2])	VA[14]	VA[14]	0b0 (DVMTyep[2])	PA[14]
ACADDR[13]	0b0 (DVMTyep[1])	0b0 (DVMTyep[1])	VA[13]	VA[13]	0b0 (DVMTyep[1])	PA[13]
ACADDR[12]	0b0 (DVMTyep[0])	0b0 (DVMTyep[0])	VA[12]	VA[12]	0b0 (DVMTyep[0])	PA[12]
ACADDR[11]	Exception[1]	Exception[1]	TG[1]	TG[1]	Exception[1]	IS[3]
ACADDR[10]	Exception[0]	Exception[0]	TG[0]	TG[0]	Exception[0]	IS[2]
ACADDR[9]	Security[1]	Security[1]	TTL[1]	TTL[1]	Security[1]	IS[1]
ACADDR[8]	Security[0]	Security[0]	TTL[0]	TTL[0]	Security[0]	IS[0]
ACADDR[7]	0b0 (Range)	Range	0b0	Scale[1]	Range	0b0
ACADDR[6]	VMIDV	VMIDV	0b0	Scale[0]	0b0 (VMIDV)	0b0
ACADDR[5]	ASIDV	ASIDV	0b0	Num[4]	0b0 (ASIDV)	0b0
ACADDR[4]	Leaf	Leaf	0b0	Num[3]	Leaf	0b0
ACADDR[3]	Stage[1]	Stage[1]	VA[40]	VA[40]	Stage[1]	0b0
ACADDR[2]	Stage[0]	Stage[0]	0b0	Num[2]	Stage[0]	0b0
ACADDR[1]	0b0	0b0	0b0	Num[1]	0b0	0b0
ACADDR[0]	0b0 (Addr)	0b1 (Addr)	0b0	Num[0]	Addr	0b0
ACVMIDEXT[3]	VMID[11]	VMID[11]	VMID[15]	VMID[15]	0b0	0b0
ACVMIDEXT[2]	VMID[10]	VMID[10]	VMID[14]	VMID[14]	0b0	0b0
ACVMIDEXT[1]	VMID[9]	VMID[9]	VMID[13]	VMID[13]	0b0	0b0
ACVMIDEXT[0]	VMID[8]	VMID[8]	VMID[12]	VMID[12]	0b0	0b0

The mappings for Branch Predictor Invalidate and Sync messages are shown in [Table A15.21](#).

**Table A15.21: Field mappings for BPI and Sync messages**

Signal	BPI all or Sync	BPI by VA 1st part	BPI by VA 2nd part
ACADDR[51]	0b0	0b0	0b0
ACADDR[50]	0b0	0b0	0b0
ACADDR[49]	0b0	0b0	0b0
ACADDR[48]	0b0	0b0	0b0
ACADDR[47]	0b0	VA[56]	VA[52]
ACADDR[46]	0b0	VA[55]	VA[51]
ACADDR[45]	0b0	VA[54]	VA[50]
ACADDR[44]	0b0	VA[53]	VA[49]
ACADDR[43]	0b0	VA[48]	VA[44]
ACADDR[42]	0b0	VA[47]	VA[43]
ACADDR[41]	0b0	VA[46]	VA[42]
ACADDR[40]	0b0	VA[45]	VA[41]
ACADDR[39]	0b0	0b0	VA[39]
ACADDR[38]	0b0	0b0	VA[38]
ACADDR[37]	0b0	0b0	VA[37]
ACADDR[36]	0b0	0b0	VA[36]
ACADDR[35]	0b0	0b0	VA[35]
ACADDR[34]	0b0	0b0	VA[34]
ACADDR[33]	0b0	0b0	VA[33]
ACADDR[32]	0b0	0b0	VA[32]
ACADDR[31]	0b0	0b0	VA[31]
ACADDR[30]	0b0	0b0	VA[30]
ACADDR[29]	0b0	0b0	VA[29]
ACADDR[28]	0b0	0b0	VA[28]
ACADDR[27]	0b0	0b0	VA[27]
ACADDR[26]	0b0	0b0	VA[26]
ACADDR[25]	0b0	0b0	VA[25]
ACADDR[24]	0b0	0b0	VA[24]
ACADDR[23]	0b0	0b0	VA[23]
ACADDR[22]	0b0	0b0	VA[22]
ACADDR[21]	0b0	0b0	VA[21]

*Continued on next page*

Table A15.21 – Continued from previous page

Signal	BPI all or Sync	BPI by VA 1st part	BPI by VA 2nd part
ACADDR[20]	0b0	0b0	VA[20]
ACADDR[19]	0b0	0b0	VA[19]
ACADDR[18]	0b0	0b0	VA[18]
ACADDR[17]	0b0	0b0	VA[17]
ACADDR[16]	0b0	0b0	VA[16]
ACADDR[15]	Completion	0b0 (Completion)	VA[15]
ACADDR[14]	DVMType[2]	0b0 (DVMType[2])	VA[14]
ACADDR[13]	DVMType[1]	0b0 (DVMType[1])	VA[13]
ACADDR[12]	DVMType[0]	0b1 (DVMType[0])	VA[12]
ACADDR[11]	0b0 (Exception[1])	0b0 (Exception[1])	VA[11]
ACADDR[10]	0b0 (Exception[0])	0b0 (Exception[0])	VA[10]
ACADDR[9]	0b0 (Security[1])	0b0 (Security[1])	VA[9]
ACADDR[8]	0b0 (Security[0])	0b0 (Security[0])	VA[8]
ACADDR[7]	0b0 (Range)	0b0 (Range)	VA[7]
ACADDR[6]	0b0 (VMIDV)	0b0 (VMIDV)	VA[6]
ACADDR[5]	0b0 (ASIDV)	0b0 (ASIDV)	VA[5]
ACADDR[4]	0b0 (Leaf)	0b0 (Leaf)	VA[4]
ACADDR[3]	0b0 (Stage[1])	0b0 (Stage[1])	VA[40]
ACADDR[2]	0b0 (Stage[0])	0b0 (Stage[0])	0b0
ACADDR[1]	0b0	0b0	0b0
ACADDR[0]	0b0 (Addr)	0b1 (Addr)	0b0
ACVMIDEXT[3]	0b0	0b0	0b0
ACVMIDEXT[2]	0b0	0b0	0b0
ACVMIDEXT[1]	0b0	0b0	0b0
ACVMIDEXT[0]	0b0	0b0	0b0

The mappings for Instruction Cache Invalidation messages are shown in [Table A15.22](#).

**Table A15.22: Field mappings for VICI and PICI messages**

Signal	VICI all	VICI by VA 1st part	VICI by VA 2nd part	PICI 1st part	PICI 2nd part
ACADDR[51]	0b0	0b0	0b0	0b0	PA[51]
ACADDR[50]	0b0	0b0	0b0	0b0	PA[50]
ACADDR[49]	0b0	0b0	0b0	0b0	PA[49]
ACADDR[48]	0b0	0b0	0b0	0b0	PA[48]
ACADDR[47]	0b0	VA[56]	VA[52]	0b0	PA[47]
ACADDR[46]	0b0	VA[55]	VA[51]	0b0	PA[46]
ACADDR[45]	0b0	VA[54]	VA[50]	0b0	PA[45]
ACADDR[44]	0b0	VA[53]	VA[49]	0b0	PA[44]
ACADDR[43]	VMID[15]	VA[48]	VA[44]	0b0	PA[43]
ACADDR[42]	VMID[14]	VA[47]	VA[43]	0b0	PA[42]
ACADDR[41]	VMID[13]	VA[46]	VA[42]	0b0	PA[41]
ACADDR[40]	VMID[12]	VA[45]	VA[41]	0b0	PA[40]
ACADDR[39]	ASID[15]	ASID[15]	VA[39]	0b0	PA[39]
ACADDR[38]	ASID[14]	ASID[14]	VA[38]	0b0	PA[38]
ACADDR[37]	ASID[13]	ASID[13]	VA[37]	0b0	PA[37]
ACADDR[36]	ASID[12]	ASID[12]	VA[36]	0b0	PA[36]
ACADDR[35]	ASID[11]	ASID[11]	VA[35]	0b0	PA[35]
ACADDR[34]	ASID[10]	ASID[10]	VA[34]	0b0	PA[34]
ACADDR[33]	ASID[9]	ASID[9]	VA[33]	0b0	PA[33]
ACADDR[32]	ASID[8]	ASID[8]	VA[32]	0b0	PA[32]
ACADDR[31]	VMID[7]	VMID[7]	VA[31]	VI[27]	PA[31]
ACADDR[30]	VMID[6]	VMID[6]	VA[30]	VI[26]	PA[30]
ACADDR[29]	VMID[5]	VMID[5]	VA[29]	VI[25]	PA[29]
ACADDR[28]	VMID[4]	VMID[4]	VA[28]	VI[24]	PA[28]
ACADDR[27]	VMID[3]	VMID[3]	VA[27]	VI[23]	PA[27]
ACADDR[26]	VMID[2]	VMID[2]	VA[26]	VI[22]	PA[26]
ACADDR[25]	VMID[1]	VMID[1]	VA[25]	VI[21]	PA[25]
ACADDR[24]	VMID[0]	VMID[0]	VA[24]	VI[20]	PA[24]
ACADDR[23]	ASID[7]	ASID[7]	VA[23]	VI[19]	PA[23]
ACADDR[22]	ASID[6]	ASID[6]	VA[22]	VI[18]	PA[22]

*Continued on next page*

Table A15.22 – Continued from previous page

Signal	VICI all	VICI by VA 1st part	VICI by VA 2nd part	PICI 1st part	PICI 2nd part
ACADDR[21]	ASID[5]	ASID[5]	VA[21]	VI[17]	PA[21]
ACADDR[20]	ASID[4]	ASID[4]	VA[20]	VI[16]	PA[20]
ACADDR[19]	ASID[3]	ASID[3]	VA[19]	VI[15]	PA[19]
ACADDR[18]	ASID[2]	ASID[2]	VA[18]	VI[14]	PA[18]
ACADDR[17]	ASID[1]	ASID[1]	VA[17]	VI[13]	PA[17]
ACADDR[16]	ASID[0]	ASID[0]	VA[16]	VI[12]	PA[16]
ACADDR[15]	0b0 (Completion)	0b0 (Completion)	VA[15]	0b0 (Completion)	PA[15]
ACADDR[14]	0b0 (DVMType[2])	0b0 (DVMType[2])	VA[14]	0b0 (DVMType[2])	PA[14]
ACADDR[13]	0b1 (DVMType[1])	0b1 (DVMType[1])	VA[13]	0b1 (DVMType[1])	PA[13]
ACADDR[12]	0b1 (DVMType[0])	0b1 (DVMType[0])	VA[12]	0b0 (DVMType[0])	PA[12]
ACADDR[11]	Exception[1]	Exception[1]	VA[11]	0b0 (Exception[1])	PA[11]
ACADDR[10]	Exception[0]	Exception[0]	VA[10]	0b0 (Exception[0])	PA[10]
ACADDR[9]	Security[1]	Security[1]	VA[9]	Security[1]	PA[9]
ACADDR[8]	Security[0]	Security[0]	VA[8]	Security[0]	PA[8]
ACADDR[7]	0b0 (Range)	0b0 (Range)	VA[7]	0b0 (Range)	PA[7]
ACADDR[6]	VMIDV	VMIDV	VA[6]	VIV[1]	PA[6]
ACADDR[5]	ASIDV	ASIDV	VA[5]	VIV[0]	PA[5]
ACADDR[4]	0b0 (Leaf)	0b0 (Leaf)	VA[4]	0b0	PA[4]
ACADDR[3]	0b0 (Stage[1])	0b0 (Stage[1])	VA[40]	0b0	0b0
ACADDR[2]	0b0 (Stage[0])	0b0 (Stage[0])	0b0	0b0	0b0
ACADDR[1]	0b0	0b0	0b0	0b0	0b0
ACADDR[0]	0b0 (Addr)	0b1 (Addr)	0b0	Addr	0b0
ACVMIDEXT[3]	VMID[11]	VMID[11]	VMID[15]	0b0	0b0
ACVMIDEXT[2]	VMID[10]	VMID[10]	VMID[14]	0b0	0b0
ACVMIDEXT[1]	VMID[9]	VMID[9]	VMID[13]	0b0	0b0
ACVMIDEXT[0]	VMID[8]	VMID[8]	VMID[12]	0b0	0b0

## A15.5 DVM Sync and Complete

A DVM Sync message is used when the requester needs to know when all previous invalidations are complete.

A DVM Complete request is sent when a component has received a DVM Sync message and all preceding invalidation operations are complete. The following rules apply in determining when an operation is complete:

### TLB Invalidate

Complete when a Manager can no longer use an invalidated translation and all previous transactions that could have used an invalidated translation are complete.

### Branch Predictor Invalidate

Complete when cached copies of predicted instruction fetches have been invalidated and can no longer be accessed by the associated Manager. The invalidated cached copies might be from any virtual address or from a specified virtual address.

### Instruction Cache Invalidate

Complete when cached instructions have been invalidated and can no longer be accessed by the associated Manager.

The synchronization flow between an interconnect and one receiving Manager is shown in [Figure A15.3](#).

The process is:

1. The Manager acknowledges receipt of the DVM Sync message using the snoop response (CR) channel. This response must not be dependent on the forward progress of any transactions on the AR or AW channels.
2. The Manager must issue a DVM Complete request on the AR channel when it has completed all the necessary actions. This must be after the handshake of the associated DVM Sync on the snoop request channel of the same Manager. The Manager must send a DVM Complete in a timely manner, even if it continues to receive more DVM invalidation operations and more DVM Sync messages.
3. The interconnect component responds to the DVM Complete request using the read data (R) channel of the component that issued the DVM Complete. Read data is not valid in this response.

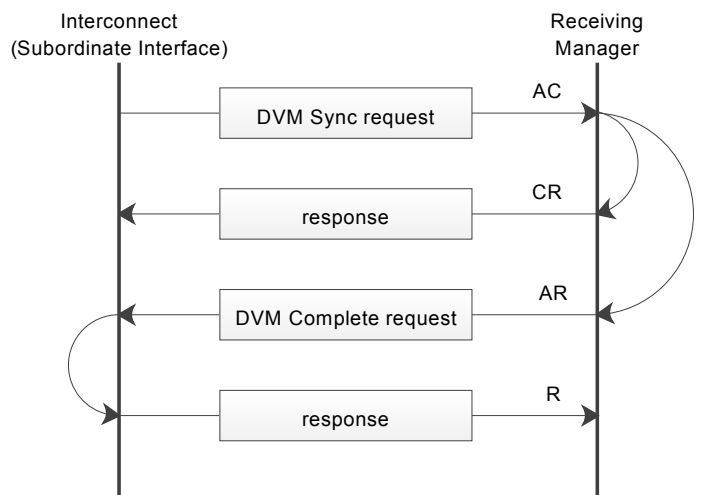

**Figure A15.3: DVM Synchronization flow**

A DVM Complete request is signaled on the AR channel, [Table A15.23](#) shows the constraints on other AR channel signals if they are present.

**Table A15.23: DVM Complete request constraints**

<b>Signal</b>	<b>Constraint</b>
ARSNOOP	Must be 0b1110.
ARADDR	Must be zero.
ARID	Must be different from that of any outstanding, non-DVM Complete transaction on the read channels.
ARBURST	Must be INCR (0b01).
ARLEN	Must be 1 transfer (0x00).
ARSIZE	Must be equal to the data channel width.
ARDOMAIN	Must be Shareable (0b01 or 0b10).
ARCACHE	Must be Modifiable, Non-cacheable (0b0010).
ARCHUNKEN	Must be 0b0.
ARMMUVALID	Must be 0b0.
ARMMUATST	Must be 0b0.
ARMMUFLOW	Must be 0b00.
ARTAGOP	Must be 0b00.
ARLOCK	Must be 0b0.



## A15.6 Coherency Connection signaling

DVM message requests are transferred from a Subordinate to a Manager interface, which is the opposite direction to other requests. A Manager which is idle might be powered down and unable to accept any DVM requests. Coherency Connection signaling can be used to enable a Manager to control whether it receives DVM message requests.

The `Coherency_Connection_Signals` property is used to indicate whether a component supports the Coherency Connection signals.

**Table A15.24: Coherency\_Connection\_Signals property**

Coherency_Connection_Signals	Default	Description
True		Coherency Connection signaling is supported.
False	Y	Coherency Connection signaling is not supported.

When `Coherency_Connection_Signals` is True, the following signals are included on an interface.

**Table A15.25: Coherency Connection signals**

Name	Width	Default	Description
SYSCOREQ	1	-	Output from a Manager, asserted HIGH to request that it receives DVM messages on the AC channel.
SYSCOACK	1	-	Output from a Subordinate, asserted HIGH to acknowledge that the attached Manager might receive DVM messages on the AC channel.

Coherency Connection signals do not have default values, so connected interfaces must both support or not support Coherency Connection signaling.

The Coherency Connection signals use a four-phase scheme which can safely cross clock domains.

Disconnecting from DVM messages is typically used before entering a low-power state in which DVM requests cannot be processed.

### A15.6.1 Coherency Connection Handshake

**SYSCOREQ** and **SYSCOACK** must be deasserted when **ARESETn** is asserted. When not in reset, the following requests are permitted:

- A Manager requests to receive DVM messages by asserting **SYSCOREQ** HIGH. The interconnect indicates that DVM messages are enabled by asserting **SYSCOACK** HIGH.
- The Manager requests to stop receiving DVM messages by deasserting **SYSCOREQ** LOW. The interconnect indicates that DVM messages is disabled by deasserting **SYSCOACK** LOW.

The handshake timing is shown in [Figure A15.4](#).

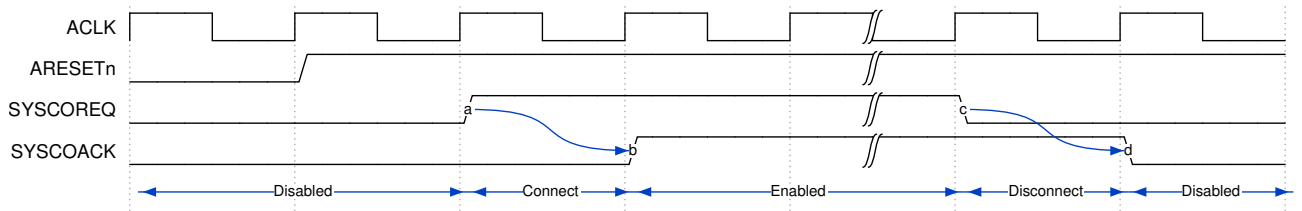

Figure A15.4: Coherency Connection handshake timing

The connection signaling obeys the four-phase handshake rules:

- A Manager can only change **SYSCOREQ** when **SYSCOACK** is at the same level.
- A Subordinate can only change **SYSCOACK** when **SYSCOREQ** is at the opposite level.

The rules for Managers and Subordinate components in each state are shown in [Table A15.26](#).

Table A15.26: Coherency Connection signaling states

State	SYSCOREQ	SYSCOACK	Rules
Disabled	0	0	<p>Manager:</p> <ul style="list-style-type: none"> <li>• Must not fetch and use DVM-managed translation table data to perform translations.</li> <li>• Asserts SYSCOREQ if it needs to perform DVM-managed translations.</li> </ul> <p>Subordinate:</p> <ul style="list-style-type: none"> <li>• Must not issue any DVM message requests.</li> <li>• Must not issue any DVM Sync requests, these are assumed to complete immediately.</li> </ul>
Connect	1	0	<p>Manager:</p> <ul style="list-style-type: none"> <li>• Must not fetch and use DVM-managed translation table data to perform translations.</li> <li>• Must be able to receive and respond to DVM message requests.</li> <li>• Waiting for SYSCOACK to be asserted before using DVM-managed translations.</li> </ul> <p>Subordinate:</p> <ul style="list-style-type: none"> <li>• Asserts SYSCOACK when it has enabled DVM messages to the attached Manager.</li> </ul>
Enabled	1	1	<p>Manager:</p> <ul style="list-style-type: none"> <li>• Can fetch and use DVM-managed translation table data.</li> <li>• Must be able to receive and respond to DVM message requests.</li> <li>• Deasserts SYSCOREQ if it has finished using DVM-managed translation table data and wants to enter a low power state. Any transaction using previously fetched data must have been completed.</li> </ul> <p>Subordinate:</p> <ul style="list-style-type: none"> <li>• Can send DVM messages to the attached Manager.</li> </ul>

Continued on next page

Table A15.26 – Continued from previous page

State	SYSCOREQ	SYSCOACK	Rules
Disconnect	0	1	<p>Manager:</p> <ul style="list-style-type: none"> <li>• Must not fetch or use any DVM-managed translation table data.</li> <li>• Must be able to receive and respond to DVM message requests.</li> <li>• Waiting for SYSCOACK to be deasserted before disabling DVM-managed logic.</li> </ul> <p>Subordinate:</p> <ul style="list-style-type: none"> <li>• Must wait for all outstanding DVM messages to receive a response before deasserting SYSCOACK.</li> <li>• Must not issue any new DVM messages.</li> <li>• Must issue the second part of a 2-part DVM message if the first part has already been issued.</li> </ul>

If an interconnect has sent a DVM Sync message that requires a DVM Complete message on the AR channel, then the interconnect is permitted to deassert **SYSCOACK** before the DVM Complete request is received. The Manager is required to send the DVM Complete request on the AR channel, even when DVM messages are disabled.

Transitions on the Coherency Connection signals might rely on **AWAKEUP** being asserted, see [A16.2.1 AWAKEUP and Coherency Connection signaling](#) for details.

## Chapter A16

# Wake-up signaling

This chapter introduces the wake-up signals for the AXI protocol.

It contains the following sections:

- [A16.1 About Wake-up signals](#)
- [A16.2 AWAKEUP rules and recommendations](#)
- [A16.3 ACWAKEUP rules and recommendations](#)

## A16.1 About Wake-up signals

The wake-up signals are an optional feature that can be used to indicate that there is activity associated with the interface.

**Table A16.1: Wake-up signals**

Name	Width	Default	Description
AWAKEUP	1	-	Manager output, asserted HIGH to indicate there might be activity on the read and write request channels.
ACWAKEUP	1	-	Subordinate output, asserted HIGH to indicate there might be activity on the snoop request channel.

The signals can be routed to a clock controller or similar component to enable power and clocks to the connected components.

The wake-up signals are synchronous and must also be suitable for sampling asynchronously in a different clock domain. This requires the wake-up signals to be glitch-free, which can be achieved by for example being generated directly from a register, or from a glitch-free OR tree.

The wake-up signals must be asserted to guarantee that a transaction can be accepted, but once the transaction is in progress the assertion or deassertion of the wake-up signal is IMPLEMENTATION DEFINED.

It is recommended, but not required that a wake-up signal is deasserted when no further transactions are required.

The Wakeup\_Signals property is used to indicate whether a component includes wake-up signaling.

**Table A16.2: Wakeup\_Signals property**

Wakeup_Signals	Default	Description
True		AWAKEUP is present. ACWAKEUP is present if the interface has an AC channel.
False	Y	No wake-up signals are present.

## A16.2 AWAKEUP rules and recommendations

**AWAKEUP** is an output signal from a Manager interface and is asserted at the start of a transaction to indicate that there is a transaction to be processed. It has the following rules:

- It is recommended that **AWAKEUP** is asserted at least one cycle before the assertion of **ARVALID**, **AWVALID**, or **WVALID** to prevent the acceptance of a transaction request being delayed.
- It is permitted for **AWAKEUP** to be asserted at any point before or after the assertion of **ARVALID**, **AWVALID**, or **WVALID**.
- A Subordinate is permitted to wait for **AWAKEUP** to be asserted before asserting **ARREADY**, **AWREADY**, or **WREADY**.
- If **AWAKEUP** is asserted in a cycle where **AWVALID** is asserted and **AWREADY** is deasserted, then **AWAKEUP** must remain asserted until **AWREADY** is asserted.
- If **AWAKEUP** is asserted in a cycle when **ARVALID** is asserted and **ARREADY** is deasserted, then **AWAKEUP** must remain asserted until **ARREADY** is asserted.
- After the **ARVALID**, **ARREADY** handshake, or the **AWVALID**, **AWREADY** handshake, the interconnect must remain active until the transaction has completed.
- It is permitted, but not recommended, to assert **AWAKEUP** then deassert it without a transaction taking place.

There is no requirement relating to the assertion of **AWAKEUP** relative to **WVALID**. However, for components that can assert **WVALID** before **AWVALID**, the assertion of **AWAKEUP** at least one cycle before **WVALID** can prevent the acceptance of a new transaction being delayed.

If a Subordinate has an **AWAKEUP** input but the attached Manager does not have an **AWAKEUP** output, then either:

- Tie **AWAKEUP** high, however this might prevent the Subordinate interface from using low-power states.
- Derive **AWAKEUP** from **AxVALID** and **SYSCOREQ/ACK**. This method enables the Subordinate to use low-power states, but might introduce latency while the clock is enabled.

### A16.2.1 AWAKEUP and Coherency Connection signaling

If wake-up and Coherency Connection signals are both present on an interface, there are additional considerations.

- It is required that the **AWAKEUP** signal is asserted to guarantee progress of a transition on the Coherency Connection signaling.
- It is permitted for **AWAKEUP** to be asserted at any point before or after the assertion of **SYSCOREQ**. However, it is required to be asserted to guarantee the corresponding assertion of **SYSCOACK**. When **AWAKEUP** is asserted with **SYSCOREQ** asserted and **SYSCOACK** deasserted, it must remain asserted until **SYSCOACK** is asserted.
- It is permitted for **AWAKEUP** to be asserted at any point before or after the deassertion of **SYSCOREQ**. However, it is required to be asserted to guarantee the corresponding deassertion of **SYSCOACK**. When **AWAKEUP** is asserted with **SYSCOREQ** deasserted and **SYSCOACK** asserted, it must remain asserted until **SYSCOACK** is deasserted.

See [A15.6 Coherency Connection signaling](#) for more details.

## A16.3 ACWAKEUP rules and recommendations

**ACWAKEUP** is an output signal from a Subordinate interface, usually on an interconnect, and is asserted at the start of a DVM message transaction to indicate that there is a transaction to be processed. It has the following rules:

- It is recommended that **ACWAKEUP** is asserted at least one cycle before the assertion of **ACVALID** to prevent the acceptance of a DVM request being delayed.
- **ACWAKEUP** must remain asserted until the associated **ACVALID** / **ACREADY** handshake to ensure progress of the DVM transaction.
- After the **ACVALID** / **ACREADY** handshake, the Manager must remain active until the DVM transaction has completed.
- It is permitted for **ACWAKEUP** to be asserted at any point before or after the assertion of **ACVALID**.
- It is permitted, but not recommended, to assert **ACWAKEUP** and then deassert it without **ACVALID** being asserted.

## Chapter A17

# Interface and data protection

This chapter specifies schemes for the protection of data and interfaces using poison and parity signaling.

It contains the following sections:

- [A17.1 Data protection using Poison](#)
- [A17.2 Parity protection for data and interface signals](#)



## A17.1 Data protection using Poison

Poison signaling is used to indicate that a set of data bytes has been previously corrupted. Passing the Poison signaling alongside the data permits any future user of the data to be notified that the data might be corrupt. Poison signaling is supported at the granularity of 1 bit for every 64 bits of data.

**Table A17.1: Poison signals**

Name	Width	Default	Description
WPOISON, RPOISON	ceil(DATA_WIDTH / 64)	-	Asserted high to indicates that the data in this transfer is corrupted. There is one bit per 64-bits of data.

The presence of Poison signals is configured using the *Poison* property.

**Table A17.2: Poison property**

Poison	Default	Description
True		Poison signaling is supported.
False	Y	Poison signaling is not supported.

The validity of the Poison signaling is identical to the validity of the associated data.

Poison signaling is independent of error response signaling:

- It is permitted to signal an error with no Poison violation.
- It is permitted to signal a Poison violation without signaling an error response.

A 64-bit granule is defined to be an 8-byte address range that is aligned to an 8-byte boundary.

Where the transaction size, as indicated by **AxSIZE**, is less than 64-bits then it is permitted for the Poison bit to be different on each data transfer. In this situation the receiving component must examine all data transfers to determine if the 64-bit granule is poisoned.

Poison bits can be set for data lanes that are invalid for a transfer. For example, a 64-bit transfer on a 128-bit channel can have both Poison bits set.

For implications of Poison with MTE Tags, see [A13.2.10 MTE and Poison](#).

## A17.2 Parity protection for data and interface signals

For safety-critical applications it is necessary to detect and possibly correct, transient and functional errors on individual wires within an SoC.

An error in a system component can propagate and cause multiple errors within connected components. Error detection and correction (EDC) is required to operate end-to-end, covering all logic and wires from source to destination.

One way to implement end-to-end protection, is to employ customized EDC schemes in components and implement a simple error detection scheme between components. Between these components there is no logic and single bit errors do not propagate to multi-bit errors. This section describes a parity scheme for detecting single-bit errors on the AMBA interface between components. Multi-bit errors can be detected if they occur in different parity signal groups. [Figure A17.1](#) shows locations where parity can be used in AMBA.

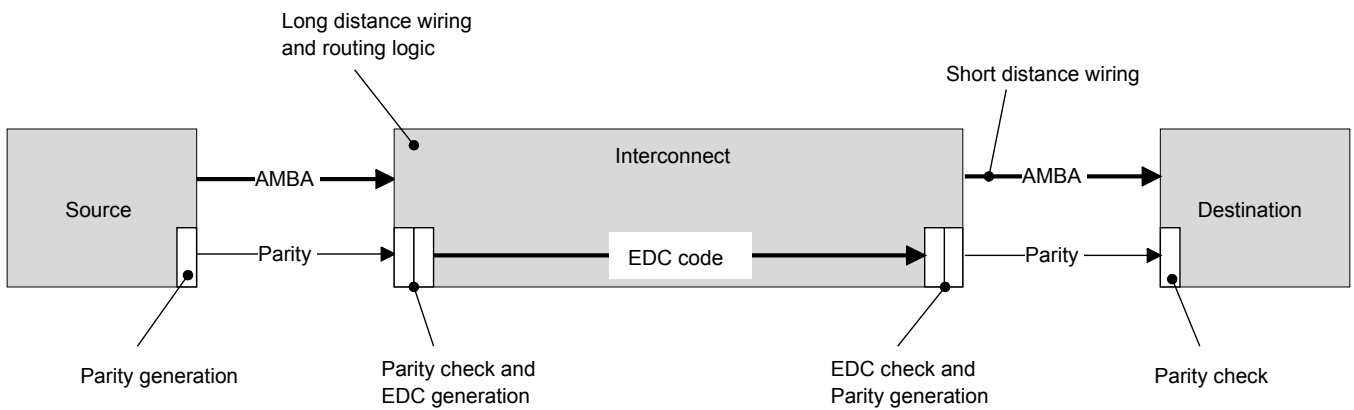

Figure A17.1: Parity use in AMBA

### A17.2.1 Configuration of parity protection

The protection scheme employed on an interface is defined by the property *Check\_Type*.

Table A17.3: *Check\_Type* property

Check_Type	Default	Description
Odd_Parity_Byte_All		Odd parity checking included for all signals. Each bit of the parity signal generally covers up to 8 bits. However, a parity bit can cover more than 8 bits if the configuration requires it.
Odd_Parity_Byte_Data		Odd parity checking included for data signals with names that end in DATA. Each bit of the parity signal covers exactly 8 bits.
False	Y	No checking signals on the interface.

## A17.2.2 Error detection behavior

This specification is not prescriptive regarding component or system behavior when a parity error is detected. Depending on the system and affected signals, a flipped bit can have a wide range of effects. It might be harmless, cause performance issues, data corruption, security violations, or deadlock. The transaction response is independent of parity error detection.

When an error is detected, the receiver can do any of the following:

- Terminate or propagate the transaction. Termination might or might not be protocol-compliant.
- Correct the parity check signal or propagate the signal in error.
- Update its memory or leave untouched. The location might be marked as poisoned.
- Signal an error response through other means, for example with an interrupt.

## A17.2.3 Parity check signals

The parity check signals are listed in [Table A17.4](#). They have the following attributes and rules:

- Odd parity is used.  
Odd parity means that check signals are added to groups of signals on the interface and driven such that there is always an odd number of asserted bits in that group.
- Parity signals covering data and payload are defined such that in most cases, there are no more than 8 bits per group.  
This limitation assumes that there is a maximum of 3 logic levels available in the timing budget for generating each parity bit.
- Parity signals covering critical control signals, which are likely to have a smaller timing budget available, are defined with a single odd parity bit. This single odd parity bit is the inversion of the original critical control signal.
- For a check signal that is wider than 1 bit:
  - Where a check signal covers multiple signals, parity is calculated by concatenating the signals in the order they are listed in [Table A17.4](#), with the first signal listed at the LSB.
  - Check bit [n] corresponds to bits [(8n+7):8n] in the payload, with the following exceptions:
    - \* **WTAGCHK[n]** is the parity of {**WTAGUPDATE[n]**,**WTAG[4n+3:4n]**}.
    - \* **RTAGCHK[n]** is the parity of **RTAG[4n+3:4n]**.
  - If the payload is not an integer number of bytes, the most significant bit of the check signal covers fewer than 8-bits in the most significant portion of the payload.
- Check signals are synchronous to **ACLK** and must be driven correctly in every cycle that the signal in the Check enable column is **HIGH**, see [Table A17.4](#).
- Parity signals must be driven appropriate to all the bits in the associated payload, irrespective of whether those bits are actively used in the transfer. For example, all bits of **WDATACHK** must be driven correctly when **WVALID** is asserted, even if some byte lanes are not being used.
- If none of the signals covered by a check signal are present on an interface, then the check signal is omitted from the interface.

The following rules apply for **CHK** signals which cover multiple signals where one or more of the inputs or outputs are missing:

- If there is a missing signal output, the value is assumed to be the default for that signal.

- If there is an output signal with no corresponding input, the missing input cannot be assumed to take a fixed value. Therefore, the **CHK** signal cannot be used reliably.
- It is recommended that input signals that are part of a **CHK** group are either all present or all not present.

**Table A17.4: Parity check signals**

Name	Signals covered	Width	Check enable
AWVALIDCHK	AWVALID	1	ARESETn
AWREADYCHK	AWREADY	1	ARESETn
AWIDCHK	AWID AWIDUNQ	ceil((ID_W_WIDTH + int(Unique_ID_Support))/8)	AWVALID
AWADDRCHK	AWADDR	ceil(ADDR_WIDTH/8)	AWVALID
AWLENCHK	AWLEN	1	AWVALID
AWCTLCHK0	AWSIZE AWBURST AWLOCK AWPROT AWNSE	1	AWVALID
AWCTLCHK1	AWREGION AWCACHE AWQOS	1	AWVALID
AWCTLCHK2	AWDOMAIN AWSNOOP	1	AWVALID
AWCTLCHK3	AWATOP AWCMO AWTAGOP	1	AWVALID
AWUSERCHK	AWUSER	ceil(USER_REQ_WIDTH/8)	AWVALID
AWSTASHNIDCHK	AWSTASHNID AWSTASHNIDEN	1	AWVALID
AWSTASHLPIDCHK	AWSTASHLPID AWSTASHLPIDEN	1	AWVALID
AWTRACECHK	AWTRACE	1	AWVALID
AWLOOPCHK	AWLOOP	ceil(LOOP_W_WIDTH/8)	AWVALID
AWMMUCHK	AWMMUATST AWMMUFLOW AWMMUSECSID AWMMUSSIDV AWMMUVALID	1	AWVALID
AWMMUSIDCHK	AWMMUSID	ceil(SID_WIDTH/8)	AWVALID
AWMMUSSIDCHK	AWMMUSSID	ceil(SSID_WIDTH/8)	AWVALID
AWPBHACHK	AWPBHA	1	AWVALID
AWNSAIDCHK	AWNSAID	1	AWVALID

*Continued on next page*

Table A17.4 – Continued from previous page

Name	Signals covered	Width	Check enable
AWMPAMCHK	AWMPAM	1	AWVALID
AWSUBSYSIDCHK	AWSUBSYSID	1	AWVALID
AWMECIDCHK	AWMECID	ceil(MECID_WIDTH/8)	AWVALID
WVALIDCHK	WVALID	1	ARESETn
WREADYCHK	WREADY	1	ARESETn
WDATACHK	WDATA	DATA_WIDTH/8	WVALID
WSTRBCHK	WSTRB	ceil(DATA_WIDTH/64)	WVALID
WTAGCHK	WTAG WTAGUPDATE	ceil(DATA_WIDTH/128)	WVALID
WLASTCHK	WLAST	1	WVALID
WUSERCHK	WUSER	ceil(USER_DATA_WIDTH/8)	WVALID
WPOISONCHK	WPOISON	ceil(DATA_WIDTH/512)	WVALID
WTRACECHK	WTRACE	1	WVALID
BVALIDCHK	BVALID	1	ARESETn
BREADYCHK	BREADY	1	ARESETn
BIDCHK	BID BIDUNQ	ceil((ID_W_WIDTH + int(Unique_ID_Support))/8)	BVALID
BRESPCHK	BRESP BCOMP BPERSIST BTAGMATCH BBUSY	1	BVALID
BUSERCHK	BUSER	ceil(USER_RESP_WIDTH/8)	BVALID
BTRACECHK	BTRACE	1	BVALID
BLOOPCHK	BLOOP	ceil(LOOP_W_WIDTH/8)	BVALID
ARVALIDCHK	ARVALID	1	ARESETn
ARREADYCHK	ARREADY	1	ARESETn
ARIDCHK	ARID ARIDUNQ	ceil((ID_R_WIDTH + int(Unique_ID_Support))/8)	ARVALID
ARADDRCHK	ARADDR	ceil(ADDR_WIDTH/8)	ARVALID
ARLENCHK	ARLEN	1	ARVALID
ARCTLCHK0	ARSIZE ARBURST ARLOCK ARPROT ARNSE	1	ARVALID

Continued on next page

Table A17.4 – Continued from previous page

Name	Signals covered	Width	Check enable
ARCTLCHK1	ARREGION ARCACHE ARQOS	1	ARVALID
ARCTLCHK2	ARDOMAIN ARSNOOP	1	ARVALID
ARCTLCHK3	ARCHUNKEN ARTAGOP	1	ARVALID
ARUSERCHK	ARUSER	ceil(USER_REQ_WIDTH/8)	ARVALID
ARTRACECHK	ARTRACE	1	ARVALID
ARLOOPCHK	ARLOOP	ceil(LOOP_R_WIDTH/8)	ARVALID
ARMMUCHK	ARMMUATST ARMMUFLOW ARMMUSECSID ARMMUSSIDV ARMMUVALID	1	ARVALID
ARMMUSIDCHK	ARMMUSID	ceil(SID_WIDTH/8)	ARVALID
ARMMUSSIDCHK	ARMMUSSID	ceil(SSID_WIDTH/8)	ARVALID
ARNSAIDCHK	ARNSAID	1	ARVALID
ARMPAMCHK	ARMPAM	1	ARVALID
ARPBHACHK	ARPBHA	1	ARVALID
ARSUBSYSIDCHK	ARSUBSYSID	1	ARVALID
ARMECIDCHK	ARMECID	ceil(MECID_WIDTH/8)	ARVALID
RVALIDCHK	RVALID	1	ARESETn
RREADYCHK	RREADY	1	ARESETn
RIDCHK	RID RIDUNQ	ceil((ID_R_WIDTH + int(Unique_ID_Support))/8)	RVALID
RDATACHK	RDATA	DATA_WIDTH/8	RVALID
RTAGCHK	RTAG	ceil(DATA_WIDTH/128)	RVALID
RRESPCHK	RRESP RBUSY	1	RVALID
RLASTCHK	RLAST	1	RVALID
RCHUNKCHK	RCHUNKV RCHUNKNUM RCHUNKSTRB	1	RVALID
RUSERCHK	RUSER	ceil((USER_DATA_WIDTH + USER_RESP_WIDTH)/8)	RVALID
RPOISONCHK	RPOISON	ceil(DATA_WIDTH/512)	RVALID

Continued on next page

Table A17.4 – Continued from previous page

<b>Name</b>	<b>Signals covered</b>	<b>Width</b>	<b>Check enable</b>
RTRACECHK	RTRACE	1	RVALID
RLOOPCHK	RLOOP	ceil(LOOP_R_WIDTH/8)	RVALID
ACVALIDCHK	ACVALID	1	ARESETn
ACREADYCHK	ACREADY	1	ARESETn
ACADDRCHK	ACADDR	ceil(ADDR_WIDTH/8)	ACVALID
ACVMIDEXTCHK	ACVMIDEXT	1	ACVALID
ACTRACECHK	ACTRACE	1	ACVALID
CRVALIDCHK	CRVALID	1	ARESETn
CRREADYCHK	CRREADY	1	ARESETn
CRTRACECHK	CRTRACE	1	CRVALID
VAWQOSACCEPTCHK	VAWQOSACCEPT	1	ARESETn
VARQOSACCEPTCHK	VARQOSACCEPT	1	ARESETn
AWAKEUPCHK	AWAKEUP	1	ARESETn
ACWAKEUPCHK	ACWAKEUP	1	ARESETn
SYSCOREQCHK	SYSCOREQ	1	None
SYSCOACKCHK	SYSCOACK	1	None

# Part B

## Appendices



## Chapter B1

# Interface classes

The specification part in this document describes a generic fully-featured protocol, with some features being mandatory and others optional, based on properties. Previous issues of this specification defined a number of interface classes for different use-cases. These can all now be described by constraining certain properties to limit the functionality and signaling on that interface.

This chapter describes the following interface classes:

- [B1.1.1 AXI5](#)
- [B1.1.2 ACE5-Lite](#)
- [B1.1.3 ACE5-LiteDVM](#)
- [B1.1.4 ACE5-LiteACP](#)
- [B1.1.5 AXI5-Lite](#)

There are also signal and property tables with columns for each interface class:

- [B1.2 Signal matrix](#)
- [B1.3 Parity check signal matrix](#)
- [B1.4 Property matrix](#)

Note that ACE, ACE5, AXI3, AXI4, and AXI4-Lite interface classes are not described in this specification. See [1] for more information on these interfaces.

## B1.1 Summary of interface classes

An example of where different interface classes might be used is shown in [Figure B1.1](#). Note that an AXI5 interface can be configured to meet all of the use-cases.

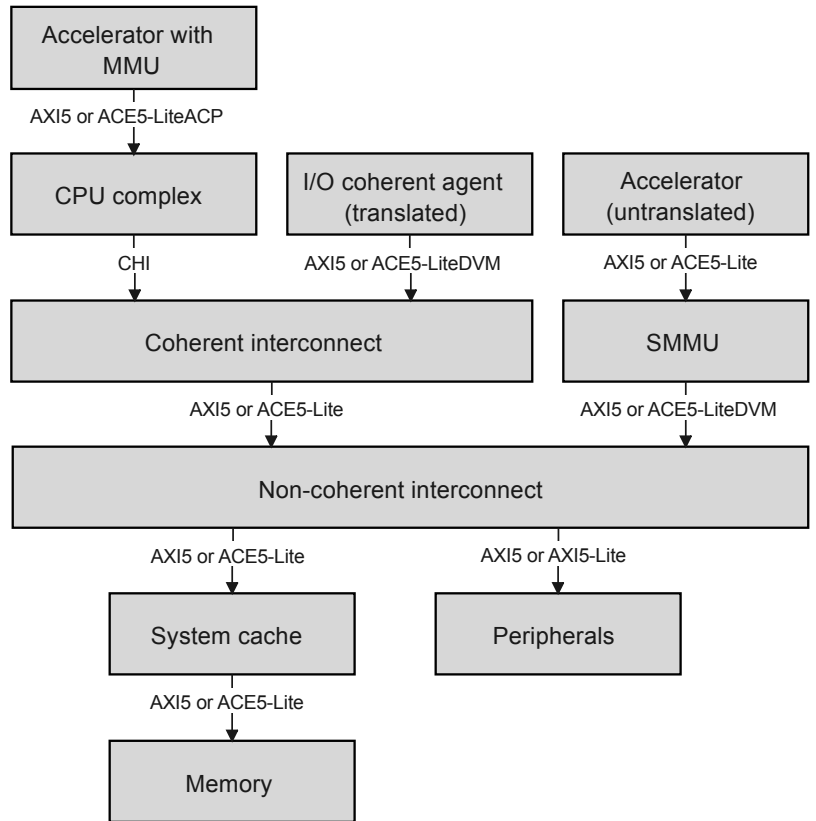

Figure B1.1: Example system topology showing possible interface classes

### B1.1.1 AXI5

The AXI5 interface class is a generic interface with no property constraints.

Compared with Issue H of this specification, the following properties are now permitted to be enabled for an AXI5 interface:

- Shareable\_Transactions
- CMO\_On\_Read
- CMO\_On\_Write
- Write\_Plus\_CMO
- WriteZero\_Transaction
- Prefetch\_Transaction
- Cache\_Stash\_Transactions
- DVM\_Message\_Support (Receiver only)
- DVM\_v8, DVM\_v8.1, DVM\_v8.4, DVM\_v9.2
- Coherency\_Connection\_Signals
- DeAllocation\_Transactions
- Persist\_CMO

### B1.1.2 ACE5-Lite

An ACE5-Lite interface was previously needed if an AXI interface included any functionality that required **AxSNOOP** signals. With this version of the specification, an AXI5 interface is recommended for new designs as it now supports all functionality.

### B1.1.3 ACE5-LiteDVM

An ACE5-LiteDVM interface was previously needed if an interface was required to send or receive DVM messages. With this version of the specification, an AXI5 interface is recommended for new designs as it now supports all functionality.

The most common use-case for an ACE5-LiteDVM interface is for a system MMU to receive invalidation messages on the AC channel. The issuing of DVM messages on the AR channel is mostly done by fully coherent CPUs, so is beyond the scope of this specification.

Note that there are some differences between the definition of ACE5-LiteDVM in this specification, compared with Issue H [1].

In this specification, snoop data transfer and bidirectional DVM messages are not supported. Therefore, the following signals described in earlier issues of this specification are no longer required on an ACE5-LiteDVM interface:

- **ACSNOOP**, all requests on the AC channel can be assumed to be DVM messages.
- **ACPROT**, not required for DVM messages.
- **CRRESP**, not required for DVM messages.

#### B1.1.4 ACE5-LiteACP

ACE5-LiteACP, which is a subset of ACE5-Lite, is intended for tightly coupling accelerator components to a processor cluster. The interface is optimized for coherent cache line accesses and is less complex than an ACE5-Lite interface.

The following constraints apply to ACE5-LiteACP in order to reduce complexity.

- Data width must be 128b (DATA\_WIDTH = 128).
- Size must be 128b (SIZE\_Present = False).
- Length must be 1 or 4 transfers.
- Burst must be INCR (BURST\_Present = False).
- Memory type must be Write-back, that is **AxCACHE[1:0]** is 0b11 and **AxCACHE[3:2]** is not 0b00.
- Some other optional features are not permitted, as [Table B1.4](#) describes.

#### B1.1.5 AXI5-Lite

AXI5-Lite is a subset of AXI5 where all transactions have one data transfer. It is intended for communication with register-based components and simple memories when bursts of data transfer are not advantageous.

The key functionality of AXI5-Lite is:

- All transactions have burst length 1.
- Supported Opcodes are WriteNoSnoop and ReadNoSnoop.
- Reordering of responses is permitted when requests have different IDs.
- All accesses are considered Device Non-bufferable.
- Exclusive accesses are not supported.

## B1.2 Signal matrix

In [Table B1.2](#), there is a list of all signals with codes that describe the presence requirements for each interface class. The Presence column describes the property condition used to specify the presence of the signal.

The list of codes that are used is shown in [Table B1.1](#).

**Table B1.1: Key to signals table**

Code	Manager interfaces	Subordinate interfaces
Y	Mandatory	Mandatory
YM	Mandatory	Optional
YS	Optional	Mandatory
O	Optional	Optional
NS	Optional	Not present
N	Not present	Not present

**Table B1.2: Summary of signal presence for each interface class**

Signal	Presence	AXI5	ACE5-Lite	ACE5-LiteDVM	ACE5-LiteACP	AXI5-Lite
<a href="#">ACLK</a>	-	Y	Y	Y	Y	Y
<a href="#">ARESETn</a>	-	Y	Y	Y	Y	Y
<a href="#">AWVALID</a>	-	Y	Y	Y	Y	Y
<a href="#">AWREADY</a>	-	Y	Y	Y	Y	Y
<a href="#">AWID</a>	ID_W_WIDTH > 0	YS	YS	YS	YS	YS
<a href="#">AWADDR</a>	-	Y	Y	Y	Y	Y
<a href="#">AWREGION</a>	REGION_Present	O	O	O	N	N
<a href="#">AWLEN</a>	LEN_Present	YS	YS	YS	YS	N
<a href="#">AWSIZE</a>	SIZE_Present	YS	YS	YS	N	O
<a href="#">AWBURST</a>	BURST_Present	YS	YS	YS	N	N
<a href="#">AWLOCK</a>	Exclusive_Accesses	O	O	O	N	N
<a href="#">AWCACHE</a>	CACHE_Present	O	O	O	O	N
<a href="#">AWPROT</a>	PROT_Present	YM	YM	YM	YM	YM
<a href="#">AWNSE</a>	RME_Support	O	O	O	N	N
<a href="#">AWQOS</a>	QOS_Present	O	O	O	N	N
<a href="#">AWUSER</a>	USER_REQ_WIDTH > 0	O	O	O	O	O
<a href="#">AWDOMAIN</a>	Shareable_Transactions	O	Y	Y	Y	N

*Continued on next page*

Table B1.2 – Continued from previous page

Signal	Presence	AXI5	ACE5-Lite	ACE5-LiteDVM	ACE5-LiteACP	AXI5-Lite
AWSNOOP	AWSNOOP_WIDTH > 0	O	YS	YS	YS	N
AWSTASHNID	STASHNID_Present	O	O	O	O	N
AWSTASHNIDEN	STASHNID_Present	O	O	O	O	N
AWSTASHLPID	STASHLPID_Present	O	O	O	O	N
AWSTASHLPIDEN	STASHLPID_Present	O	O	O	O	N
AWTRACE	Trace_Signals	O	O	O	O	O
AWLOOP	Loopback_Signals	O	O	O	N	N
AWMMUVALID	Untranslated_Transactions == v3	O	O	N	N	N
AWMMUSECSID	SECSID_WIDTH > 0	O	O	N	N	N
AWMMUSID	SID_WIDTH > 0	O	O	N	N	N
AWMMUSSIDV	SSID_WIDTH > 0	O	O	N	N	N
AWMMUSSID	SSID_WIDTH > 0	O	O	N	N	N
AWMMUATST	MMUFLOW_Present and ((Untranslated_Transactions == v1) or (Untranslated_Transactions == True))	O	O	N	N	N
AWMMUFLOW	MMUFLOW_Present and ((Untranslated_Transactions == v2) or (Untranslated_Transactions == v3))	O	O	N	N	N
AWPBHA	PBHA_Support	O	O	O	N	N
AWMECID	MEC_Support	O	O	O	N	N
AWNSAID	NSAccess_Identifiers	O	O	O	N	N
AWSUBSYSID	SUBSYSID_WIDTH > 0	O	O	O	N	O
AWATOP	Atomic_Transactions	O	O	O	N	N
AWMPAM	MPAM_Support != False	O	O	O	O	N
AWIDUNQ	Unique_ID_Support	O	O	O	O	O
AWCMO	CMO_On_Write	O	O	O	N	N
AWTAGOP	MTE_Support != False	O	O	O	N	N
WVALID	-	Y	Y	Y	Y	Y
WREADY	-	Y	Y	Y	Y	Y
WDATA	-	Y	Y	Y	Y	Y
WSTRB	WSTRB_Present	YS	YS	YS	YS	YS
WTAG	MTE_Support != False	O	O	O	N	N
WTAGUPDATE	MTE_Support != False	O	O	O	N	N

Continued on next page

Table B1.2 – Continued from previous page

Signal	Presence	AXI5	ACE5- Lite	ACE5- LiteDVM	ACE5- LiteACP	AXI5- Lite
WLAST	WLAST_Present	YM	YM	YM	YM	N
WUSER	USER_DATA_WIDTH > 0	O	O	O	O	O
WPOISON	Poison	O	O	O	O	O
WTRACE	Trace_Signals	O	O	O	O	O
BVALID	-	Y	Y	Y	Y	Y
BREADY	-	Y	Y	Y	Y	Y
BID	ID_W_WIDTH > 0	YS	YS	YS	YS	YS
BIDUNQ	Unique_ID_Support	O	O	O	O	O
BRESP	BRESP_WIDTH > 0	O	O	O	O	O
BCOMP	(Persist_CMO and CMO_On_Write) or MTE_Support == Standard	O	O	O	N	N
BPERSIST	Persist_CMO and CMO_On_Write	O	O	O	N	N
BTAGMATCH	MTE_Support == Standard	O	O	N	N	N
BUSER	USER_RESP_WIDTH > 0	O	O	O	O	O
BTRACE	Trace_Signals	O	O	O	O	O
BLOOP	Loopback_Signals	O	O	O	N	N
BBUSY	Busy_Support	O	O	O	N	N
ARVALID	-	Y	Y	Y	Y	Y
ARREADY	-	Y	Y	Y	Y	Y
ARID	ID_R_WIDTH > 0	YS	YS	YS	YS	YS
ARADDR	-	Y	Y	Y	Y	Y
ARREGION	REGION_Present	O	O	O	N	N
ARLEN	LEN_Present	YS	YS	YS	YS	N
ARSIZE	SIZE_Present	YS	YS	YS	N	O
ARBURST	BURST_Present	YS	YS	YS	N	N
ARLOCK	Exclusive_Accesses	O	O	O	N	N
ARCACHE	CACHE_Present	O	O	O	O	N
ARPROT	PROT_Present	YM	YM	YM	YM	YM
ARNSE	RME_Support	O	O	O	N	N
ARQOS	QOS_Present	O	O	O	N	N
ARUSER	USER_REQ_WIDTH > 0	O	O	O	O	O
ARDOMAIN	Shareable_Transactions	O	Y	Y	Y	N

Continued on next page

Table B1.2 – Continued from previous page

Signal	Presence	AXI5	ACE5-Lite	ACE5-LiteDVM	ACE5-LiteACP	AXI5-Lite
ARSNOOP	ARSNOOP_WIDTH > 0	O	YS	YS	O	N
ARTRACE	Trace_Signals	O	O	O	O	O
ARLOOP	Loopback_Signals	O	O	O	N	N
ARMMUVALID	Untranslated_Transactions == v3	O	O	N	N	N
ARMMUSECSID	SECSID_WIDTH > 0	O	O	N	N	N
ARMMUSID	SID_WIDTH > 0	O	O	N	N	N
ARMMUSSIDV	SSID_WIDTH > 0	O	O	N	N	N
ARMMUSSID	SSID_WIDTH > 0	O	O	N	N	N
ARMMUATST	MMUFLOW_Present and ((Untranslated_Transactions == v1) or (Untranslated_Transactions == True))	O	O	N	N	N
ARMMUFLOW	MMUFLOW_Present and ((Untranslated_Transactions == v2) or (Untranslated_Transactions == v3))	O	O	N	N	N
ARPBHA	PBHA_Support	O	O	O	N	N
ARMECID	MEC_Support	O	O	O	N	N
ARNSAID	NSAccess_Identifiers	O	O	O	N	N
ARSUBSYSID	SUBSYSID_WIDTH > 0	O	O	O	N	O
ARMPAM	MPAM_Support != False	O	O	O	O	N
ARCHUNKEN	Read_Data_Chunking	O	O	O	O	N
ARIDUNQ	Unique_ID_Support	O	O	O	O	O
ARTAGOP	MTE_Support != False	O	O	O	N	N
RVALID	-	Y	Y	Y	Y	Y
RREADY	-	Y	Y	Y	Y	Y
RID	ID_R_WIDTH > 0	YS	YS	YS	YS	YS
RIDUNQ	Unique_ID_Support	O	O	O	O	O
RDATA	-	Y	Y	Y	Y	Y
RTAG	MTE_Support != False	O	O	O	N	N
RRESP	RRESP_WIDTH > 0	O	O	O	O	O
RLAST	RLAST_Present	YS	YS	YS	YS	N
RUSER	USER_DATA_WIDTH > 0 or USER_RESP_WIDTH > 0	O	O	O	O	O
RPOISON	Poison	O	O	O	O	O
RTRACE	Trace_Signals	O	O	O	O	O

Continued on next page



Table B1.2 – Continued from previous page

Signal	Presence	AXI5	ACE5-Lite	ACE5-LiteDVM	ACE5-LiteACP	AXI5-Lite
RLOOP	Loopback_Signals	O	O	O	N	N
RCHUNKV	Read_Data_Chunking	O	O	O	O	N
RCHUNKNUM	RCHUNKNUM_WIDTH > 0	O	O	O	O	N
RCHUNKSTRB	RCHUNKSTRB_WIDTH > 0	O	O	O	O	N
RBUSY	Busy_Support	O	O	O	N	N
ACVALID	DVM_Message_Support	O	N	Y	N	N
ACREADY	DVM_Message_Support	O	N	Y	N	N
ACADDR	DVM_Message_Support	O	N	Y	N	N
ACVMIDEXT	DVM_Message_Support and (DVM_v8.1 or DVM_v8.4 or DVM_v9.2)	O	N	O	N	N
ACTRACE	DVM_Message_Support and Trace_Signals	O	N	O	N	N
CRVALID	DVM_Message_Support	O	N	Y	N	N
CRREADY	DVM_Message_Support	O	N	Y	N	N
CRTRACE	DVM_Message_Support and Trace_Signals	O	N	O	N	N
AWAKEUP	Wakeup_Signals	O	O	O	O	O
ACWAKEUP	Wakeup_Signals and DVM_Message_Support	O	N	O	N	N
VARQOSACCEPT	QoS_Accept	O	O	O	N	N
VAWQOSACCEPT	QoS_Accept	O	O	O	N	N
SYSCOREQ	Coherency_Connection_Signals	O	N	O	N	N
SYSCOACK	Coherency_Connection_Signals	O	N	O	N	N
BROADCASTATOMIC	-	NS	NS	NS	N	N
BROADCASTSHAREABLE	-	NS	NS	NS	NS	N
BROADCASTCACHEMAINT	-	NS	NS	NS	N	N
BROADCASTCMOPOPA	-	NS	NS	NS	N	N
BROADCASTPERSIST	-	NS	NS	NS	N	N

## B1.3 Parity check signal matrix

Parity check signals for each interface type are shown in [Table B1.3](#), using the codes defined in [Table B1.1](#). Parity check signals are described in [A17.2.3 Parity check signals](#).

**Table B1.3: Summary of check signal presence for each interface class**

Signal	AXI5	ACE5-Lite	ACE5-LiteDVM	ACE5-LiteACP	AXI5-Lite
AWVALIDCHK	O	O	O	O	O
AWREADYCHK	O	O	O	O	O
AWIDCHK	O	O	O	O	O
AWADDRCHK	O	O	O	O	O
AWLENCHK	O	O	O	O	N
AWCTLCHK0	O	O	O	O	O
AWCTLCHK1	O	O	O	O	N
AWCTLCHK2	O	O	O	O	N
AWCTLCHK3	O	O	O	N	N
AWUSERCHK	O	O	O	O	O
AWSTASHNIDCHK	O	O	O	O	N
AWSTASHLPIDCHK	O	O	O	O	N
AWTRACECHK	O	O	O	O	O
AWLOOPCHK	O	O	O	N	N
AWMMUCHK	O	O	N	N	N
AWMMUSIDCHK	O	O	N	N	N
AWMMUSSIDCHK	O	O	N	N	N
AWPBHACHK	O	O	O	N	N
AWNSAIDCHK	O	O	O	N	N
AWMPAMCHK	O	O	O	O	N
AWSUBSYSIDCHK	O	O	O	N	O
AWMECIDCHK	O	O	O	N	N
WVALIDCHK	O	O	O	O	O
WREADYCHK	O	O	O	O	O
WDATACHK	O	O	O	O	O
WSTRBCHK	O	O	O	O	O
WTAGCHK	O	O	O	N	N
WLASTCHK	O	O	O	O	N

*Continued on next page*

Table B1.3 – Continued from previous page

Signal	AXI5	ACE5- Lite	ACE5- LiteDVM	ACE5- LiteACP	AXI5- Lite
WUSERCHK	O	O	O	O	O
WPOISONCHK	O	O	O	O	O
WTRACECHK	O	O	O	O	O
BVALIDCHK	O	O	O	O	O
BREADYCHK	O	O	O	O	O
BIDCHK	O	O	O	O	O
BRESPCHK	O	O	O	O	O
BUSERCHK	O	O	O	O	O
BTRACECHK	O	O	O	O	O
BLOOPCHK	O	O	O	N	N
ARVALIDCHK	O	O	O	O	O
ARREADYCHK	O	O	O	O	O
ARIDCHK	O	O	O	O	O
ARADDRCHK	O	O	O	O	O
ARLENCHK	O	O	O	O	N
ARCTLCHK0	O	O	O	O	O
ARCTLCHK1	O	O	O	O	N
ARCTLCHK2	O	O	O	O	N
ARCTLCHK3	O	O	O	O	N
ARUSERCHK	O	O	O	O	O
ARTRACECHK	O	O	O	O	O
ARLOOPCHK	O	O	O	N	N
ARMMUCHK	O	O	N	N	N
ARMMUSIDCHK	O	O	N	N	N
ARMMUSSIDCHK	O	O	N	N	N
ARNSAIDCHK	O	O	O	N	N
ARMPAMCHK	O	O	O	O	N
ARPBHACHK	O	O	O	N	N
ARSUBSYSIDCHK	O	O	O	N	O
ARMECIDCHK	O	O	O	N	N
RVALIDCHK	O	O	O	O	O
RREADYCHK	O	O	O	O	O

Continued on next page

Table B1.3 – Continued from previous page

Signal	AXI5	ACE5- Lite	ACE5- LiteDVM	ACE5- LiteACP	AXI5- Lite
RIDCHK	O	O	O	O	O
RDATACHK	O	O	O	O	O
RTAGCHK	O	O	O	N	N
RRESPCHK	O	O	O	O	O
RLASTCHK	O	O	O	O	N
RCHUNKCHK	O	O	O	O	N
RUSERCHK	O	O	O	O	O
RPOISONCHK	O	O	O	O	O
RTRACECHK	O	O	O	O	O
RLOOPCHK	O	O	O	N	N
ACVALIDCHK	O	N	O	N	N
ACREADYCHK	O	N	O	N	N
ACADDRCHK	O	N	O	N	N
ACVMIDEXTCHK	O	N	O	N	N
ACTRACECHK	O	N	O	N	N
CRVALIDCHK	O	N	O	N	N
CRREADYCHK	O	N	O	N	N
CRTRACECHK	O	N	O	N	N
VAWQOSACCEPTCHK	O	O	O	N	N
VARQOSACCEPTCHK	O	O	O	N	N
AWAKEUPCHK	O	O	O	O	O
ACWAKEUPCHK	O	N	O	N	N
SYSCOREQCHK	O	N	O	N	N
SYSCOACKCHK	O	N	O	N	N

## B1.4 Property matrix

A list of all properties is shown in [Table B1.4](#).

The table shows the document issue in which the property was introduced and all legal values for the property. There is a column for each interface class which shows the legal values of that property for that interface class. A dash means there are no constraints on the property value.

Note that for User signals and User Loopback signals, the maximum width values are a recommendation rather than a rule. See [A13.5 User defined signaling](#) and [A13.4 User Loopback signaling](#) for more information.

**Table B1.4: Summary of interface property constraints**

Property	Issue	Values	AXI5	ACE5-Lite	ACE5-LiteDVM	ACE5-LiteACP	AXI5-Lite
ADDR_WIDTH	H	1..64	-	-	-	-	-
ARNOOP_WIDTH	J	0, 4	-	-	-	-	0
Atomic_Transactions	F	True, False	-	-	-	False	False
AWCMO_WIDTH	J	0, 2, 3	-	-	-	0	0
AWSNOOP_WIDTH	J	0, 4, 5	-	-	-	-	0
BRESP_WIDTH	J	0, 2, 3	-	-	-	-	-
BURST_Present	J	True, False	-	-	-	False	False
Busy_Support	J	True, False	-	-	-	False	False
Cache_Line_Size	K	16, 32, 64, 128, 256, 512, 1024, 2048	-	-	-	-	-
CACHE_Present	J	True, False	-	-	-	-	False
Cache_Stash_Transactions	F	True, Basic, False	-	-	-	-	False
Check_Type	F	Odd_Parity_Byte_All, Odd_Parity_Byte_Data, False	-	-	-	-	-
CMO_On_Read	G	True, False	-	-	-	False	False
CMO_On_Write	G	True, False	-	-	-	False	False
Coherency_Connection_Signals	F	True, False	-	False	-	False	False
Consistent_DECERR	H	True, False	-	-	-	-	True
DATA_WIDTH	H	8, 16, 32, 64, 128, 256, 512, 1024	-	-	-	128	-
DeAllocation_Transactions	F	True, False	-	-	-	False	False
Device_Normal_Independence	K	True, False	-	-	-	-	-
DVM_Message_Support	H	Receiver, False	-	False	Receiver	False	False
DVM_v8	E	True, False	-	False	-	False	False
DVM_v8.1	F	True, False	-	False	-	False	False

*Continued on next page*

Table B1.4 – Continued from previous page

Property	Issue	Values	AXI5	ACE5-Lite	ACE5-LiteDVM	ACE5-LiteACP	AXI5-Lite
DVM_v8.4	H	True, False	-	False	-	False	False
DVM_v9.2	J	True, False	-	False	-	False	False
Exclusive_Accesses	H	True, False	-	-	-	False	False
Fixed_Burst_Disable	K	True, False	-	-	-	False	False
ID_R_WIDTH	H	0..32	-	-	-	-	-
ID_W_WIDTH	H	0..32	-	-	-	-	-
InvalidateHint_Transaction	J	True, False	-	-	-	False	False
LEN_Present	J	True, False	-	-	-	-	False
LOOP_R_WIDTH	H	0..8	-	-	-	0	0
LOOP_W_WIDTH	H	0..8	-	-	-	0	0
Loopback_Signals	F	True, False	-	-	-	False	False
Max_Transaction_Bytes	H	64, 128, 256, 512, 1024, 2048, 4096	-	-	-	-	-
MMUFLOW_Present	J	True, False	-	-	False	False	False
MEC_Support	K	True, False	-	-	-	False	False
MECID_WIDTH	K	0..16	-	-	-	0	0
MPAM_Support	K	MPAM_9_1, MPAM_12_1, False	-	-	-	-	False
MPAM_WIDTH	K	0, 11, 12, 14, 15	-	-	-	-	0
MTE_Support	K	Standard, Simplified, Basic, False	-	-	Basic, False	False	False
Multi_Copy_Atomicity	E	True, False	-	-	-	-	-
NSAccess_Identifiers	F	True, False	-	-	-	False	False
Ordered_Write_Observation	E	True, False	-	-	-	-	-
PBHA_Support	J	True, False	-	-	-	False	False
PROT_Present	J	True, False	-	-	-	-	-
Persist_CMO	F	True, False	-	-	-	False	False
Poison	F	True, False	-	-	-	-	-
Prefetch_Transaction	H	True, False	-	-	-	False	False
QoS_Accept	F	True, False	-	-	-	False	False
QOS_Present	J	True, False	-	-	-	False	False
RCHUNKNUM_WIDTH	J	0, 1, 5, 6, 7, 8	-	-	-	-	0
RCHUNKSTRB_WIDTH	J	0, 1, 2, 4, 8	-	-	-	-	0

Continued on next page

Table B1.4 – Continued from previous page

Property	Issue	Values	AXI5	ACE5-Lite	ACE5-LiteDVM	ACE5-LiteACP	AXI5-Lite
Read_Data_Chunking	G	True, False	-	-	-	-	False
Read_Interleaving_Disabled	G	True, False	-	-	-	-	False
REGION_Present	J	True, False	-	-	-	False	False
Regular_Transactions_Only	H	True, False	-	-	-	False	False
RLAST_Present	J	True, False	-	-	-	-	False
RME_Support	J	True, False	-	-	-	False	False
RRESP_WIDTH	J	0, 2, 3	-	-	-	-	-
SECSID_WIDTH	J	0, 1, 2	-	-	0	0	0
Shareable_Cache_Support	J	True, False	-	-	False	False	False
Shareable_Transactions	H	True, False	-	True	True	True	False
SID_WIDTH	H	0..32	-	-	0	0	0
SIZE_Present	J	True, False	-	-	-	False	-
SSID_WIDTH	H	0..20	-	-	0	0	0
STASHLPID_Present	J	True, False	-	-	-	-	False
STASHNID_Present	J	True, False	-	-	-	-	False
SUBSYSID_WIDTH	J	0..8	-	-	-	0	-
Trace_Signals	F	True, False	-	-	-	-	-
Unique_ID_Support	G	True, False	-	-	-	-	-
UnstashTranslation_Transaction	J	True, False	-	-	False	False	False
Untranslated_Transactions	F	v3, v2, v1, True, False	-	-	False	False	False
USER_DATA_WIDTH	H	0..DATA_WIDTH/2	-	-	-	-	-
USER_REQ_WIDTH	H	0..128	-	-	-	-	-
USER_RESP_WIDTH	H	0..16	-	-	-	-	-
WLAST_Present	J	True, False	-	-	-	-	False
WSTRB_Present	J	True, False	-	-	-	-	-
Wakeup_Signals	F	True, False	-	-	-	-	-
Write_Plus_CMO	H	True, False	-	-	-	False	False
WriteDeferrable_Transaction	J	True, False	-	-	-	False	False
WriteZero_Transaction	H	True, False	-	-	-	False	False
WriteNoSnoopFull_Transaction	K	True, False	-	-	-	False	False

## Chapter B2

# Summary of ID constraints

The following restrictions on ID usage are specified in this document.

Must use an ID that is unique in-flight:

- Atomic transactions
- Prefetch transactions
- WriteZero transactions
- WriteDeferrable transactions
- InvalidateHint transactions
- Read transactions with data chunking enabled
- Transactions which transport MTE tags
- UnstashTranslation transactions

Must not use the same ID for in-flight transactions:

- DVM Complete and non-DVM Complete transactions
- StashOnce and non-StashOnce transactions
- StashTranslation and non-StashTranslation transactions

Must use the same ID:

- Multiple outstanding requests that require ordering between them.
- Transactions in an exclusive access pair.



## Chapter B3

# Revisions

This appendix describes the technical changes between released issues of this specification.

It contains the following sections:

- [B3.1 Differences between Issue H.c and Issue J](#)
- [B3.2 Differences between Issue J and Issue K](#)

## B3.1 Differences between Issue H.c and Issue J

Feature	Change	Detail
AXI3, AXI4, AXI4-Lite interfaces	Removal	AXI3, AXI4, and AXI4-Lite content is removed from the specification. These interface types are not recommended for new designs and have been superseded by the AXI5 interface. Removed content can be accessed by downloading earlier versions of this specification.
ACE and ACE5 interfaces	Removal	ACE and ACE5 content is removed from the specification. AMBA CHI is recommended for fully coherent agents and is actively supported.
ACE5-Lite, ACE5-LiteDVM, ACE5-LiteACP, and AXI5-Lite interfaces	Update	ACE5-Lite, ACE5-LiteDVM, ACE5-LiteACP, and AXI5-Lite interfaces are described through constraints on property values and signal presence.
AXI5 interface	New feature	All optional features in this specification are now applicable to AXI5 class interfaces. AXI5 is expected to be used for general-purpose interfaces.
Caching shareable lines	New feature	Support for storing shareable lines in a system cache.
Cache stashing	New feature	There is an additional <i>Basic</i> option for cache stashing to support interfaces which use only a sub-set of the cache stashing protocol.
Invalidate hint	New feature	InvalidateHint transaction, which can be used by an agent when it is finished working with a data set and that data might be allocated in a downstream cache.
WriteDeferrable transaction	New feature	A 64-byte atomic store operation that might not be accepted by the Subordinate.
Realm Management Extension (RME)	New feature	Enhanced memory protection.
DVM v9.2	New feature	New messages to support the Armv9.2 architecture.
Untranslated transactions	New feature	Version 3 adds support for mixing translated and untranslated transactions.
	New feature	UnstashTranslation transaction, used as a deallocation hint for an address translation cache.
Page-based Hardware Attributes (PBHA)	New feature	4-bit descriptors associated with a translation table entry that can be annotated onto a transaction request.
Subsystem Identifier	New feature	An additional identifier that can be added to transaction requests to indicate from which subsystem they originate.
Subordinate busy	New feature	Response signal that indicates the level of activity of a Subordinate.
Unique ID indicator	Clarification	Added rules for the Unique ID Indicator and Atomic transactions that include read and write responses.
	Correction	BIDUNQ is not required to follow AWIDUNQ for non-Completion write responses such as Persist and MTE Match.
Memory Tagging Extension (MTE)	Clarification	A WritePtlCMO or WriteFullCMO with AWTAGOP Transfer must be Non-shareable. This is because a WriteUnique with AWTAGOP of Transfer is not permitted.

Continued on next page

Table B3.1 – Continued from previous page

Feature	Change	Detail
	Clarification	Transactions that carry MTE tags must not cross a cache line boundary.
	Additional requirement	Read transactions with the MTE opcode of Fetch must be Regular.
	Enhancement	The text describing MTE and Poison is enhanced with additional guidance.
Prefetch transaction	Clarification	A Prefetch request must not be used to signal that a line can be fetched into a managed or visible cache.
Wakeup signals	Clarification	It is permitted for Wakeup signals to be driven from a glitch-free OR tree if that implementation is safe for asynchronous sampling.
Multi-copy atomicity	Update	The requirements for multi-copy atomicity are updated for the Armv8 architecture.
Exclusive accesses	Update	New signals are added to the rules for an exclusive sequence.
	Clarification	The requirements for AxCACHE in an exclusive access have been redefined to be easier to understand.
Read response	Clarification	For read responses where data is not required to be valid, the Manager might still sample the RDATA value so the Subordinate should not rely on the response to hide sensitive data.
Interface parity	Enhancement	The description regarding how to handle missing signals in CHK groups is enhanced to cover the case where either the input or output is missing.
Signal matrix	Correction	The ARDOMAIN and AWDOMAIN entries in the signal matrix are corrected to be dependent on the Shareable_Transactions property and marked as Configurable rather than Mandatory.
Cache stashing	Correction	<i>"AWSTASHLPIDEN must be driven to all zeros when AWSTASHLPIDEN is deasserted"</i> is corrected to: <i>"When AWSTASHLPIDEN is LOW, AWSTASHLPID is invalid and must be zero"</i>

## B3.2 Differences between Issue J and Issue K

Feature	Change	Detail
Memory Encryption Contexts (MEC)	New feature	The Memory Encryption Contexts (MEC) feature is added to the Realm Management Extension (RME).
MPAM extension	Enhancement	A new configuration option is defined for MPAM to support a wider PartID field.
MTE extension	Enhancement	A new configuration option is defined for MTE to support components which transport tags but do not support the Match operation.
Fixed_Burst_Disable	Enhancement	A new property is defined that allows components to not support a Burst type of FIXED.
Cache_Line_Size	Enhancement	A new property is defined to capture the cache line size of an interface.
WriteNoSnoopFull Transaction	Enhancement	A new WriteNoSnoopFull_Transaction property is defined to enable an interface to support WriteNoSnoopFull without having to support all transactions related to caching shareable lines.
Write channel dependency	Clarification	It is clarified that a Subordinate must not block acceptance of data-less write requests due to transactions with leading write data.
Length attribute	Clarification	It is clarified that Size x Length defines that maximum number of bytes in a transaction rather than the actual number in all cases.
Transaction equations	Correction	The Data_Bytes variable is corrected to be DATA_WIDTH/8.
Transaction pseudocode	Clarification	Variable names changed to align with earlier sections.
Ordering between Device and Normal Non-cacheable	Enhancement	A property Device_Normal_Independence is added to control whether Device and Normal Non-cacheable requests are required to be ordered against each other.
CACHE_Present	Clarification	It is clarified that the CACHE_Present property determines whether AxCACHE signals are present on an interface.
Cache stash property	Correction	In the paragraph text and <a href="#">Table A9.19</a> , the Cache_Stash_Transactions property was incorrectly referred to as Stash_Transactions.
Max_Transaction_Bytes	Clarification	Clarification on the meaning of the Max_Transaction_Bytes property.
Write data strobes	Clarification	Clarification of the rules for WSTRB.
Read data interleaving	Clarification	It is clarified that read data transfers in Atomic transactions can be interleaved.
Modifiable transactions	Clarification	It is clarified that AxNSE must not be modified, along with AxPROT.
Exclusive accesses	Clarification	It is clarified that AWATOP must not be Match for exclusive writes.
PREFETCHED response	Change	The recommendation for PREFETCHED response is changed to be: within a cache line, the PREFETCHED response is used for all data transfers or no data transfers. This aligns better with the CHI DataSource response.
Caching shareable lines	Clarification	It is clarified that clean evictions of Shareable lines must not be written back to memory.
	Clarification	In <a href="#">Table A9.8</a> , <i>CacheStash*</i> is replaced with <i>StashOnce*</i> .

Continued on next page

Table B3.2 – Continued from previous page

Feature	Change	Detail
Memory Tagging	Clarification	A footnote is added to <a href="#">Table A13.13</a> to clarify that a WriteNoSnoop with tag Match must not be Exclusive.
	Correction	In <a href="#">Table A13.12</a> , the value for <i>Tags match</i> is corrected to be 0b11, not 0b10.
User Loopback signaling	Clarification	Clarification of the rules for LOOP_x_WIDTH properties.
MMUFLOW_Present property default	Correction	The default value for MMUFLOW_Present is corrected to be False to make it compatible with the default for the Untranslated_Transactions property.
StashTranslation and UnstashTranslation	Enhancement	StashTranslation and UnstashTranslation are enhanced to enable the stash or unstash of Granule Protection Table entries.
DVM messages	Clarification	It is clarified that the AC and CR channels are ordered.
	Correction	The mapping for the 2nd part of a PICI message was incorrect in <a href="#">Table A15.22</a> . ACADDR[11:4] should be PA[11:4].
Poison	Correction	The width of WPOISON and RPOISON is corrected to be $\text{ceil}(\text{DATA\_WIDTH}/64)$ rather than $\text{DATA\_WIDTH}/64$ .
Interface parity for CRTRACE	Correction	In <a href="#">Table A17.4</a> , the enable signal for CRTRACECHK was indicated as ACVALID when it should be CRVALID.
Loopback check signal width	Change	In <a href="#">Table A17.4</a> , the width of check signals for Loopback signals is changed from 1 to $\text{ceil}(\text{LOOP\_x\_WIDTH})$ to cover cases where the maximum recommendation of 8 for loopback width is exceeded.
ACE5-LiteDVM interface	Correction	The list of signals no longer supported in ACE5-LiteDVM is corrected to ACSNOOP, ACPROT and CRRESP.
	Correction	DVM_Message_Support must be Receiver for ACE5-LiteDVM interfaces. Therefore the snoop channels are mandatory rather than optional.
BROADCAST* signals	Correction	In the signal matrix <a href="#">Table B1.2</a> , the BROADCAST* signal presence was listed as dependent on a Broadcast_Signals property which was not defined. Presence conditions for these signals has now been removed.
Parity check signal matrix	Clarification	A matrix of parity check signals vs interface type is added for clarity.
Read Interleaving Disabled and AXI5-Lite	Correction	Read_Interleaving_Disabled was incorrectly constrained to True for AXI5-Lite interfaces, it should be False.

## **Part C**

### **Glossary**

## Chapter C1

### **Glossary**

### **Aligned**

A data item stored at an address that is divisible by the highest power of 2 that divides into its size in bytes. Aligned halfwords, words and doublewords therefore have addresses that are divisible by 2, 4 and 8 respectively.

An aligned access is one where the address of the access is aligned to the size of each element of the access.

### **At approximately the same time**

Two events occur at approximately the same time if a remote observer might not be able to determine the order in which they occurred.

### **Barrier**

An operation that forces a defined ordering of other actions.

### **Big-endian memory**

Means that *the most significant byte (MSB)* of the data is stored in the memory location with the lowest address.

### **Blocking**

Describes an operation that prevents following actions from continuing until the operation completes.

### **Branch prediction**

Is where a processor selects a future execution path to fetch along. For example, after a branch instruction, the processor can choose to speculatively fetch either the instruction following the branch or the instruction at the branch target.

### **Byte**

An 8-bit data item.

### **Cache**

Any cache, buffer, or other storage structure in a caching Manager that can hold a copy of the data value for a particular address location.

### **Cache hit**

A memory access that can be processed at high speed because the data it addresses is already in the cache.

### **Cache line**

The basic unit of storage in a cache. Its size in words is always a power of two. A cache line must be aligned to the size of the cache line.

### **Cache miss**

A memory access that cannot be processed at high speed because the data it addresses is not in the cache.

### **ceil()**

A function that returns the lowest integer value that is equal to or greater than the input to the function.

### **Coherent**

Data accesses from a set of observers to a memory location are coherent accesses to that memory location by the members of the set of observers are consistent with there being a single total order of all writes to that memory location by all members of the set of observers.

### **Component**

A distinct functional unit that has at least one AMBA interface. Component can be used as a general term for Manager, Subordinate, peripheral, and interconnect components.

### **Deprecated**



Something that is present in the specification for backwards compatibility. Whenever possible you must avoid using deprecated features. These features might not be present in future versions of the specification.

### **Downstream**

An AXI transaction operates between a Manager component and one or more Subordinate components, and can pass through one or more intermediate components. At any intermediate component, for a given transaction, *downstream* means between that component and a destination Subordinate component, and includes the destination Subordinate component.

Downstream and upstream are defined relative to the transaction as a whole, not relative to individual data flows within the transaction.

### **Downstream cache**

A downstream cache is defined from the perspective of an initiating Manager. A downstream cache for a Manager is one that it accesses using the fundamental AXI transaction channels. An initiating Manager can allocate cache lines into a downstream cache.

### **Endianness**

An aspect of the system memory mapping.

### **Full coherency**

A fully coherent Manager can share data with other Managers and allocate that data in its local caches; it can snoop and be snooped.

### **I/O coherency**

An I/O coherent Manager can share data with other Managers but cannot allocate that data in its local caches; it can snoop but not be snooped.

### **IMPLEMENTATION DEFINED**

Means that the behavior is not defined by this specification, but must be defined and documented by individual implementations.

### **in a timely manner**

The protocol cannot define an absolute time within which something must occur. However, in a sufficiently idle system, it will make progress and complete without requiring any explicit action.

### **Initiating Manager**

A Manager that issues a transaction that starts a sequence of events. When describing a sequence of transactions, the term initiating Manager distinguishes the Manager that triggers the sequence of events from any snooped Manager that is accessed as a result of the action of the initiating Manager.

Initiating Manager is a temporal definition, meaning it applies at particular points in time, and typically is used when describing sequences of events. A Manager that is an initiating Manager for one sequence of events can be a snooped Manager for another sequence of events.

### **Interconnect component**

A component with more than one AMBA interface that connects one or more Manager components to one or more Subordinate components.

An interconnect component can be used to group together either:

- A set of Managers so that they appear as a single Manager interface.
- A set of Subordinates so that they appear as a single Subordinate interface.

### **Little-endian memory**

Means that the *least significant byte* (LSB) of the data is stored in the memory location with the lowest address.

## Load

The action of a Manager component reading the value held at a particular address location. For a processor, a load occurs as the result of executing a particular instruction. Whether the load results in the Manager issuing a read transaction depends on whether the accessed cache line is held in the local cache.

## Local cache

A local cache is defined from the perspective of an initiating Manager. A local cache is one that is internal to the Manager. Any access to the local cache is performed within the Manager.

## Main memory

The memory that holds the data value of an address location when no cached copies of that location exist. For any location, main memory can be out of date with respect to the cached copies of the location, but main memory is updated with the most recent data value when no cached copies exist.

Main memory can be referred to as memory when the context makes the intended meaning clear.

## Manager

An agent that initiates transactions.

## Manager component

A component that initiates transactions.

It is possible that a single component can act as both a Manager component and as a Subordinate component. For example, a *Direct Memory Access* (DMA) component can be a Manager component when it is initiating transactions to move data, and a Subordinate component when it is being programmed.

## Memory Encryption Contexts (MEC)

Memory Encryption Contexts are configurations of encryption that are associated with areas of memory, assigned by the MMU.

MEC is an extension to the *Arm Realm Management Extension (RME)*. The RME system architecture requires that the Realm, Secure, and Root Physical Address Spaces (PAS) are encrypted. The encryption key or encryption context, used with each of these PASs is global within that PAS. For example, for the Realm PAS, all Realm memory uses the same encryption context. With MEC this concept is broadened, and for the Realm PAS specifically, each Realm is allowed to have a unique encryption context. This provides additional defense in depth to the isolation already provided in RME. MECIDs are identifying tags that are associated with different Memory Encryption Contexts.

## Memory Management Unit (MMU)

Provides detailed control of the part of a memory system that provides address translation. Most of the control is provided using translation tables that are held in memory, and define the attributes of different regions of the physical memory map.

## Memory Subordinate component

A Memory Subordinate component, or *Memory Subordinate*, is a Subordinate component with the following properties:

- A read of a byte from a Memory Subordinate returns the last value written to that byte location.
- A write to a byte location in a Memory Subordinate updates the value at that location to a new value that is obtained by subsequent reads.
- Reading a location multiple times has no side-effects on any other byte location.
- Reading or writing one byte location has no side-effects on any other byte location.

## Observer

A processor or other Manager component, such as a peripheral device, that can generate reads from or writes to memory.

### **Page-based Hardware Attributes (PBHA)**

Page Based Hardware Attributes (PBHA) is an optional, implementation defined feature. It allows software to set up to 4 bits in the translation tables, which are then propagated through the memory system with transactions, and can be used in the system to control system components. The meaning of the bits is specific to the system design.

### **Peer cache**

A peer cache is defined from the perspective of an initiating Manager. A peer cache for that Manager is one that is accessed using snoop channels. An initiating Manager cannot allocate cache lines into a peer cache.

### **Peripheral Subordinate component**

A Peripheral Subordinate component is also described as a *Peripheral Subordinate*. A Peripheral Subordinate typically has an IMPLEMENTATION DEFINED method of access that is described in the data sheet for the component. Any access that is not defined as permitted might cause the Peripheral Subordinate to fail, but must complete in a protocol-correct manner to prevent system deadlock. The protocol does not require continued correct operation of the peripheral.

In the context of the descriptions in this specification, Peripheral Subordinate is synonymous with *peripheral*, *peripheral component*, *peripheral device*, and *device*.

### **PoS**

Point of Serialization. The point through which all transactions to a given address must pass and the order in which the transactions are processed is determined.

### **Prefetching**

Prefetching refers to speculatively fetching instructions or data from the memory system. In particular, instruction prefetching is the process of fetching instructions from memory before the instructions that precede them, in simple sequential execution of the program, have finished executing. Prefetching an instruction does not mean that the instruction has to be executed.

In this specification, references to instruction or data fetching apply also to prefetching, unless the context explicitly indicates otherwise.

### **RAZ/WI, Read-As-Zero, Writes Ignored**

Hardware must implement the field as Read-as-Zero, and must ignore writes to the field. Software can rely on the field reading as all 0s, and on writes being ignored. This description can apply to a single bit that reads as 0, or to a field that reads as all 0s.

### **Realm Management Extensions (RME)**

The Realm Management Extension (RME) is an extension to the Armv9 A-profile architecture. RME is one component of the Arm Confidential Compute Architecture (Arm CCA). Together with the other components of the Arm CCA, RME enables support for dynamic, attestable and trusted execution environments (Realms) to be run on an Arm PE. RME adds two additional Security states (Root and Realm) and two physical address spaces (Root and Realm), and provides hardware-based isolation that allows execution contexts to run in different Security states and share resources in the system.

### **Snoop filter**

A precise snoop filter that is able to track precisely the cache lines that might be allocated within a Manager.

### **Snooped cache**

A hardware-coherent cache on a snooped Manager. That is, it is a hardware-coherent cache that receives snoop transactions.

The term snoop cache is used in preference to the term snoop Manager when the sequence of events being described only involves the cache and does not involve any actions or events on the associated Manager.

### **Snooped Manager**

A caching Manager that receives snoop transactions.

Snooped Manager is a temporal definition, meaning it applies at particular points in time, and typically is used when describing sequences of events. A Manager that is a snoop Manager for one sequence of events can be an initiating Manager for another sequence of events.

### **Speculative read**

A transaction that a Manager issues when it might not need the transaction to be performed because it already has a copy of the accessed cache line in its local cache. Typically, a Manager issues a speculative read in parallel with a local cache lookup. This gives lower latency than looking in the local cache first, and then issuing a read transaction only if the required cache line is not found in the local cache.

### **Store**

The action of a Manager component changing the value held at a particular address location. For a processor, a store occurs as the result of executing a particular instruction. Whether the store results in the Manager issuing a read or write transaction depends on whether the accessed cache line is held in the local cache, and if it is in the local cache, the state it is in.

### **Subordinate**

An agent that receives and responds to requests.

### **Subordinate component**

A component that receives transactions and responds to them.

It is possible that a single component can act as both a Subordinate component and as a Manager component. For example, a *Direct Memory Access* (DMA) component can be a Subordinate component when it is being programmed and a Manager component when it is initiating transactions to move data.

### **System Memory Management Unit (SMMU)**

A system-level MMU. That is, a system component that provides address translation from a one address space to another. An SMMU provides one or more of:

- *virtual address* (VA) to *physical address* (PA) translation.
- VA to *intermediate physical address* (IPA) translation.
- IPA to PA translation.

When using the Realm Management Extension (RME), an SMMU can also perform the Granule Protection Check.

### **Transaction**

An AXI Manager initiates an AXI transaction to communicate with an AXI Subordinate. Typically, the transaction requires information to be exchanged between the Manager and Subordinate on multiple channels. The complete set of required information exchanges form the AXI transaction.

### **Translation Lookaside Buffer (TLB)**

A memory structure containing the results of translation table walks. TLBs help to reduce the average cost of a memory access.

### **Translation table**

A table held in memory that defines the properties of memory areas of various sizes from 1KB.

### **Translation table walk**

The process of doing a full translation table lookup.

## Unaligned

An unaligned access is an access where the address of the access is not aligned to the size of an element of the access.

## Unaligned memory accesses

Are memory accesses that are not, or might not be, appropriately halfword-aligned, word-aligned, or doubleword-aligned.

## UNPREDICTABLE

In the AMBA AXI Architecture means that the behavior cannot be relied upon.

UNPREDICTABLE behavior must not be documented or promoted as having a defined effect.

## Upstream

An AXI transaction operates between a Manager component and one or more Subordinate components, and can pass through one or more intermediate components. At any intermediate component, for a given transaction, *upstream* means between that component and the originating Manager component, and includes the originating Manager component.

Downstream and upstream are defined relative to the transaction as a whole, not relative to individual data flows within the transaction.

## Write-Back cache

A cache in which when a cache hit occurs on a store access, the data is only written to the cache. Data in the cache can therefore be more up-to-date than data in main memory. Any such data is written back to main memory when the cache line is cleaned or re-allocated. Another common term for a Write-Back cache is a *copy-back cache*.

## Write-Through cache

A cache in which when a cache hit occurs on a store access, the data is written both to the cache and to main memory. This is normally done via a write buffer to avoid slowing down the processor.